List of Contents

1	Introduction	
1.1	Scope and Purpose	101
1.2	Applicability of Manual	101
1.3	Meaning of Warnings, Cautions and Notes	101
1.4	Additional Documentation to be used	101
1.5	Safety Information and Regulations.....	101
	1.5.1 General Safety Notes	101
1.6	Legal Provisions for Installation	102
1.7	Corrections and Improvements.....	103
2	General Description	
2.1	Combustion Air Fan	202
2.2	Fuel Pump	202
	2.2.1 Nozzle block preheater.....	202
2.3	Heat Exchanger	202
2.4	Combustion Chamber.....	202
2.5	Control Unit.....	203
2.6	Flame Sensor	203
2.7	Igniter Box with Igniter Electrodes	203
2.8	Temperature Sensor.....	203
2.9	Temperature Limiter	203
2.10	Overheat Thermostat (Thermo 231 and 301 only)	204
2.11	Circulation Pump	204
	2.11.1 Circulation Pump U 4851 and Aquavent 6000 S	204
2.12	Fuel Filter.....	205
3	Functional Description	
3.1	Switch On	302
3.2	Heating Operation.....	302
3.3	Switch Off	302
3.4	Power Save	302
3.5	Auxiliary Heating Operation (heaters with control unit 1572D only)	302
3.6	Heater Lockout (heaters with control unit 1572D only).....	302
3.7	Switch-off upon Failure (heaters with control unit 1572).....	303
3.8	Switch-off upon Failure (heaters with control unit 1572D).....	304
3.9	Error Code Output (heaters with control unit 1572D)	305
4	Technical Data	
	Electrical components.....	401
	Propellant.....	401

5	Troubleshooting	
5.1	General	501
5.2	General Fault Symptoms	501
5.3	Fault Symptoms during Functional Checkouts and Error Code Output or Tests with Diagnostic Computer, Components Tester or PC Heater Diagnosis	503
5.3.1	General.....	503
5.3.2	Fault Symptoms.....	504
6	Functional Checkouts	
6.1	General	601
6.2	Adjustments	601
6.2.1	Adjustment of CO ₂ Contents	601
6.3	Components Testing.....	602
6.3.1	Temperature Sensor Resistance Check.....	602
6.3.2	Flame Sensor Resistance Check	602
6.3.3	Igniter Electrodes Check	602
6.3.4	Igniter Box Check	603
6.3.5	Fuel Pump Check.....	603
6.3.6	Fan Motor Check.....	604
6.3.7	Solenoid Valve Check	604
6.3.8	Nozzle Block Preheater Check.....	604
7	Circuit Diagrams	
7.1	General	701
8	Servicing	
8.1	General	801
8.2	Heater Servicing	801
8.3	Vehicle Servicing	801
8.4	Heater Test Run.....	801
8.5	Maintenance	801
8.5.1	Inspection and Attachment of the Exhaust Muffler (only heaters from year of production 1996 and up to production date 1996, calendar week 36; 3G.....)	801
8.5.2	Burner Head Opening and Closing or Removal and Installation	803
8.6	Visual Inspections and Regulations for Installation.....	804
8.6.1	Connection to Vehicle Cooling System	804
8.6.2	Connection to Vehicle Fuel System.....	804
8.6.3	Combustion Air Supply	806
8.6.4	Exhaust Line	806
8.7	Removal and Installation.....	807
8.7.1	Heater, Removal and Installation	807
8.7.2	Temperature Limiter, Replacement	807
8.7.3	Temperature Sensor, Replacement	807
8.7.4	Burner, Replacement.....	807

8.7.5	Igniter Box, Replacement	807
8.7.6	Flame Sensor, Replacement	808
8.7.7	Combustion Chamber, Replacement	808
8.8	First Operation	808
8.8.1	Water Circuit, Bleeding	808
8.8.2	Fuel Supply System, Bleeding	808
9	Repair	
9.1	General	901
9.1.1	Work on Components after Disassembly	902
9.1.2	Incorporation of Modifications	902
9.2	Disassembly and Assembly	906
9.2.1	Temperature Limiter, Replacement	906
9.2.2	Temperature Sensor, Replacement	906
9.2.3	Burner, Replacement	906
9.2.4	Combustion Air Fan, Replacement	908
9.2.5	Control Unit, Replacement	910
9.2.6	Fuel Pump, Replacement	910
9.2.7	High Pressure Nozzle, Replacement	910
9.2.8	Igniter Box, Replacement	912
9.2.9	Flame Sensor, Replacement	912
9.2.10	Heat Exchanger, Replacement	914
9.2.11	Combustion Chamber, Replacement	914
10	Packaging, Storage and Shipping	
10.1	General	1001
	Annex A	
	Heater, Scheduled Maintenance	A-2

List of Figures

301	Functional Sequence (heaters with control unit 1572).....	303
302	Functional Sequence (heaters with control unit 1572D)	304
501	General Fault Symptoms	501
701	Automatic Control Circuit with Control Unit 1572 and Switch	702
702	Automatic Control Circuit with Control Unit 1572 and Timer (Triple Timer)	703
703	Automatic Control Circuit with Control Unit 1572D and Switch.....	704
704	Automatic Control Circuit with Control Unit 1572D and Standard Timer.....	705
705	System Circuit Daimler Chrysler Citaro, Ident.-Nr. 67131.....	706
706	System Circuit Van Hool, Ident.-Nr. 89401	707
707	System Circuit O405 / O407 / O408, Ident.-Nr. 91292.....	708
708	System Circuit MAN, Ident.-Nr. 89404	709
709	System Circuit SETRA, Ident.-Nr. 90972.....	710
710	Automatic Control Circuit Rail with Control Unit 1572D and Standard Timer and filter heater	711
801	Swinging Burner Head open	803
802	Example of a Heater Installation in a Passenger Bus	805
901	Temperature Limiter, Temperature Sensor and Burner, Replacement.....	907
902	Combustion Air Fan, Replacement	909
903	Control Unit and Fuel Pump, Replacement.....	911
904	Igniter Box and Flame Sensor, Replacement	912
905	Heat Exchanger and Combustion Chamber, Replacement	914

1 Introduction

1.1 Scope and Purpose

This repair shop manual is intended to support familiarized personnel in the repair of water heaters *Thermo 230, 231, 300, 301 and 350*.

The water heater may only be operated with the fuel specified on the model plate and the relevant designated type of electrical connection.

1.2 Applicability of Manual

This manual is applicable only for heaters identified on the title page. The different appearance of control units (see 2.5) allow to distinguish between model .30 and up with control unit 1572 and the model .030 and up with control unit 1572D.

In combination with control unit 1572D additionally a different type of igniter box is installed (refer to 2.7).

The heaters *Thermo 231 and 301* are variants for vertical installation.

1.3 Meaning of Warnings, Cautions and Notes

WARNINGS, CAUTIONS, and NOTES in this manual have the following meaning:

WARNING

This heading is used to highlight that non-compliance with instructions or procedures may cause injuries or lethal accidents to personnel.

CAUTION

This heading is used to highlight that non-compliance with instructions or procedures may cause damage to equipment.

NOTE

This heading is used to highlight and draw specific attention to information.

1.4 Additional Documentation to be used

This workshop manual contains all information and procedures necessary for the repair of heaters *Thermo 230, 231, 300, 301 and 350*.

The use of additional documentation is normally not necessary.

Operating instructions and installation instructions may be used as complementary information as necessary.

1.5 Safety Information and Regulations

The general safety regulations for the prevention of accidents and the relevant operating safety instructions have to be observed at all times.

"General Safety Regulations" beyond the scope of these regulations are detailed in the following.

The specific safety regulations applicable to this manual are highlighted in the individual chapters by Warnings, Cautions, and Notes.

1.5.1 General Safety Notes

The year of first operation must be permanently marked on the identification label by removing the relevant number of the year.

The heaters are cleared for heating the vehicle engine and the passenger cabin. The use of the heater in vehicles not subject to the EU Directive 70/156/EEC (e.g. ships) is partly governed by regional regulations. For heaters designed for installation in rail vehicles, type approval has been granted (not for Thermo 231 and 301) by the Federal Railway Authority with the type approval number: EBAAZ3/0141/04.

The heater may only be fitted in vehicles or in independent heating systems with a minimum coolant capacity of 10 liters.

The heater may only be installed in motor vehicles or in independent heating systems with a minimum coolant capacity of 6 liters.

The heater must not be installed in the passenger or driver compartments of vehicles. Should the heater nevertheless be installed in such a compartment, the installation box must be sealed tight against the vehicle interior. There must be sufficient ventilation of the installation box from the exterior in order not to exceed a maximum temperature of 85° C in the installation box. Excessive temperatures may cause malfunctions.

WARNING

Due to the danger of poisoning and suffocation the heater must not be operated, not even with timed

operation, in enclosed areas such as garages or workshops not equipped with an exhaust venting facility.

At filling stations and fuel depots the heater must be switched off to prevent explosions.

CAUTION

Where flammable fumes or dust may build up (e.g. in the vicinity of fuel, coal, wood, cereal depots, or similar installations) the heater must be switched off to prevent explosions.

The heater must not be operated near flammable materials such as dry grass and leaves, cardboard boxes, paper, etc.

In the vicinity of the water heater a temperature of 110° C (storage temperature) must not be exceeded under any circumstances (e.g. during body paint work).

A violation of this temperature limit may cause permanent damage to the electronics.

When checking the cooling water level proceed in accordance with the vehicle manufacturer's instructions. The water in the heating circuit of the heater must contain a minimum of 20% of a quality brand anti-freeze.

Additives in the heating circuit must not affect metals, plastics and rubber and must leave no deposits.

The opening pressure in the vehicle cooling system - normally indicated on the radiator filler cap - must be between 0.4 and 2.0 bar above operating pressure (also applicable to separate heating circuits).

1.6 Legal Provisions for Installation

With effect from 4/03, Type Approvals pursuant to EC Directives 72/245/EEC (EMC) and 2001/56/EC (Heating Systems) were granted for the heaters Thermo 230 / Thermo 231 / Thermo 300 / Thermo 301 / Thermo 350 with the following EC Type Approval Numbers:

e1*72/245*95/54*1010*--

e1*2001/56*0007*-- for Thermo 230

e1*2001/56*0008*-- for Thermo 300

e1*2001/56*0009*-- for Thermo 350

e1*2001/56*0010*-- for Thermo 231

e1*2001/56*0011*-- for Thermo 301

Up to 4/03, General Design Certifications existed for these heaters.

Installation is governed above all by the provisions in Annex VII of Directive 2001/56/EC.

NOTE:

The provisions of these Directives are binding within the territory governed by EU Directive 70/156/EEC

and should similarly be observed in countries without specific regulations.

(Extract from Directive 2001/56/EC Annex VII)

1.7.1. A clearly visible indicator within the user's field of vision must show when the heater is switched on or off.

NOTE:

For further notes and provisions relating to the installation of the heater in vehicles, refer to the installation instructions.

IMPORTANT

Failure to follow the installation instructions and the notes contained therein will lead to all liability being refused by Webasto. The same applies if repairs are carried out incorrectly or with the use of parts other than genuine spare parts. This will result in the invalidation of the type approval for the heater and therefore of its homologation / EC type licence.

Installation Instructions for Webasto fuel tanks for the fuel supply of water heaters in vehicles:

- in busses and trains the installation is not permitted in the passengers' or driver's compartment.
- the fuel filler neck must not be located in the passengers' or driver's compartment of any vehicle.
- fuel containers must either be equipped with a vent cap or any other type of ventilation (vent line).

Only vent caps in accordance with DIN 73400 may be used.

All fuel containers offered in the Webasto Accessories Catalogue are suitable for a maximum operating pressure of 0.15 bar overpressure.

All fuel containers offered in the Webasto Accessories Catalogue are subjected during manufacture to individual pressure testing with at least 0.3 bar overpressure.

- The operational state of the heater, i.e. at least an indication "on" or "off" must be easily and clearly visible.

For heaters in vehicles not ruled by the EU Directive but other regulations, the acceptance by the relevant authority is required as applicable.

1.7 Corrections and Improvements

Deficiencies, improvements, or proposals for correction of this workshop manual are to be mailed to:

Webasto AG
Abt. Technische Dokumentation Bus
D-82131 Stockdorf
Telephone: ++49 (0) 18 05 / 93 22 78
Telefax: ++49 (0) 395 7 55 92-353

2 General Description

The water heaters Webasto *Thermo 230, 231, 300, 301* and *350* are used in combination with the vehicle's own heating installation to

- heat the passenger compartment
- defrost the windscreen
- preheat water-cooled engines

The heaters *Thermo 231* and *301* are variants for vertical installation. The difference in appearance are the different identification label and the Z profiles on the installation interface.

The water heater operates independent from the vehicle engine and is connected to the vehicle cooling system, the fuel system and the electrical system.

The heater designed to the heat exchanging principle operates intermittently controlled by the temperature sensor.

The heaters *Thermo 230, 231, 300, 301* and *350* basically consist of

- the combustion air fan
- the fuel pump with nozzle block and nozzle
- the heat exchanger and
- the combustion chamber
- the igniter box with igniter electrodes

For control and monitoring the heater includes

- a control unit
- a flame sensor
- a temperature sensor
- a temperature limiter
- a temperature limiter without reset button for *Thermo 231* and *301* and *Thermo 230.126, 300.126* and *350.126 Rail*

An external circulating pump is installed inside the vehicle, or, in the case of compact units, directly at the heater.

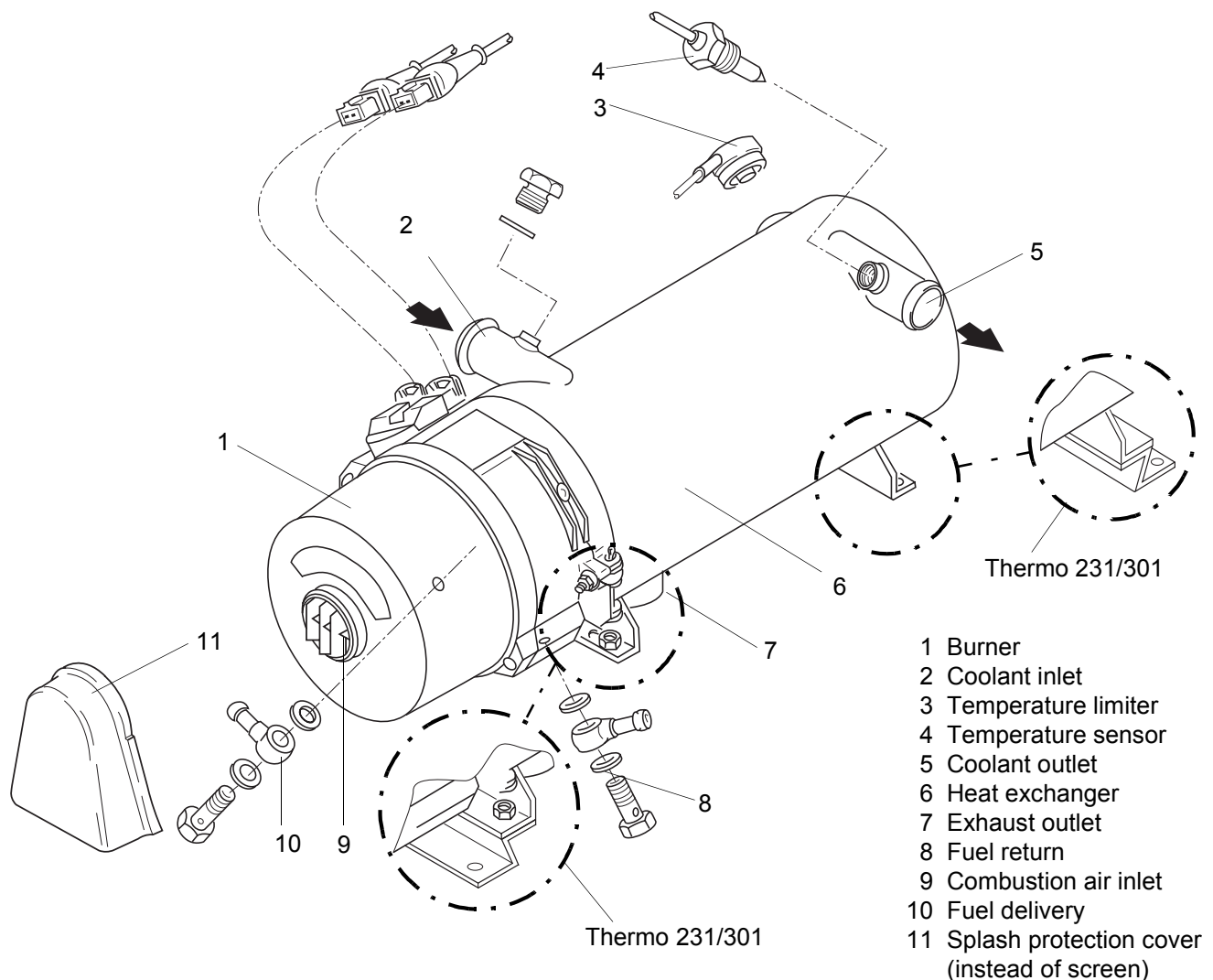

2.1 Combustion Air Fan

The combustion air fan supplies the air required for combustion from the combustion air inlet to the combustion chamber.

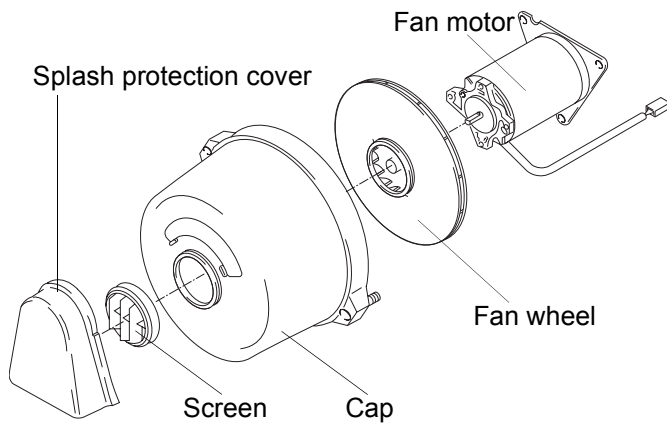

The fan consists of a fan motor with fan wheel. Air is taken in through a splash protection cover or a screen and the cap. The heaters *Thermo 231* and *301* are provided with a splash protection cover only.

2.2 Fuel Pump

The fuel pump delivers the fuel and is driven by the fan motor via a clutch. The fuel is compressed in the pump to approximately 10 bar and diffused by a high pressure nozzle. A screwed on solenoid valve controls the fuel flow to the nozzle.

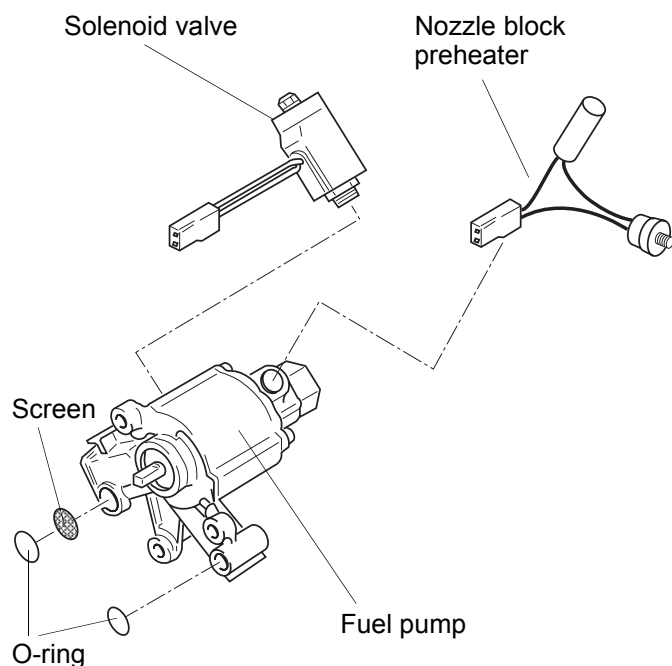

2.2.1 Nozzle block preheater

NOTE

For operation with PME (Bio Diesel) the installation of a nozzle block preheater is mandatory.

At extremely low temperatures malfunctions may occur without a nozzle block preheater. At a temperature of $< 0^{\circ}\text{C}$ a thermostat activates the heater cartridge in the nozzle block. The heating period depends on the heat reflected within the combustion chamber. Preheating is deactivated when the thermostat ambient temperature is $+8^{\circ}\text{C}$.

If the heater is not equipped with a nozzle block preheater a retrofit is possible.

2.3 Heat Exchanger

The heat exchanger transfers the heat generated by combustion to the coolant circuit.

2.4 Combustion Chamber

The fuel/air mix is dispersed in the combustion chamber for combustion to heat the heat exchanger.

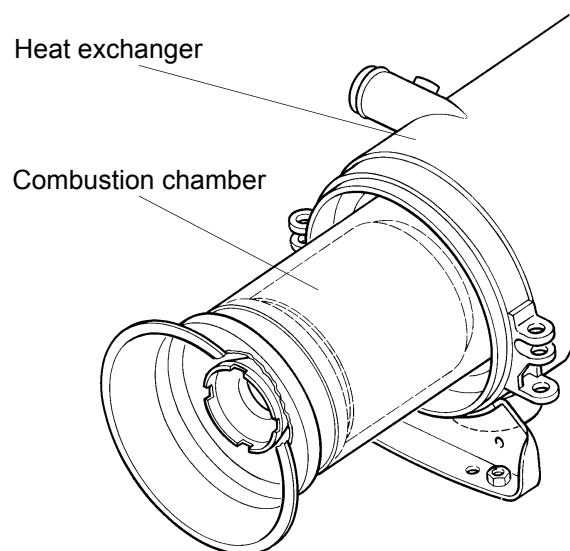

2.5 Control Unit

The control unit 1572 or 1572D is the central component to ensure controlled operation and monitoring of combustion. If the heater has a control unit 1572 installed, a retrofit of control unit 1572D is possible (see Section 9).

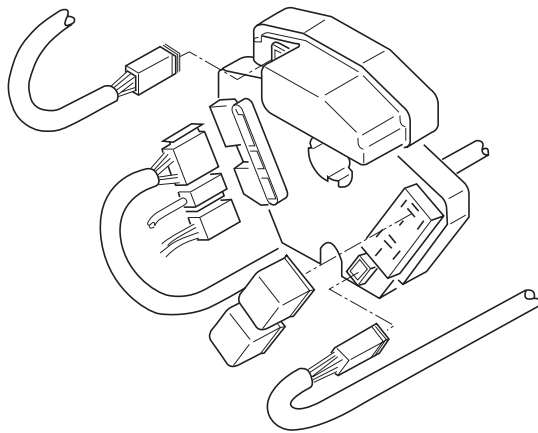

Control Unit 1572

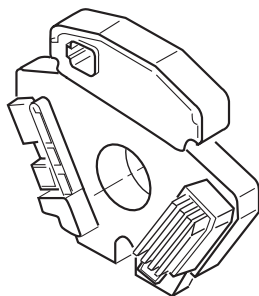

Control Unit 1572D

2.6 Flame Sensor

The flame sensor continuously monitors the flame condition during operation. The flame sensor is a photo transistor changing its resistance depending on the flame intensity. The signals are supplied to the control unit for processing.

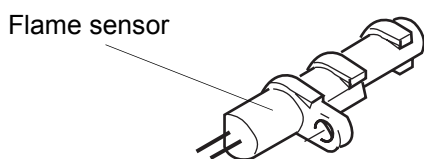

2.7 Igniter Box with Igniter Electrodes

The igniter box generates the high voltage for igniting the fuel/air mix by a high voltage ignition spark across the electrodes.

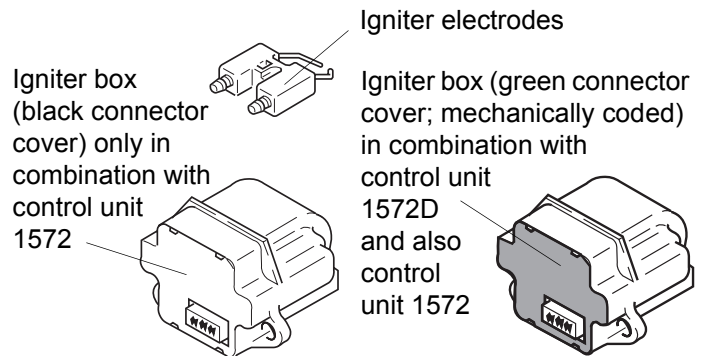

2.8 Temperature Sensor

The temperature sensor senses the coolant temperature at the heat exchanger outlet as an electrical resistance. This signal is supplied to the control unit for processing.

2.9 Temperature Limiter

The temperature limiter (bimetal) protects the heater against undue high operating temperatures. The temperature limiter can be reset manually. The temperature limiter responds at a temperature in excess of 125° C to switch off the heater. In the case of Thermo 231 and 301 and Thermo 230.126, 300.126 and 350.126 Rail, the temperature limiter will trip at a temperature in excess of 105°C. After the temperature has dropped, an automatic reset will occur.

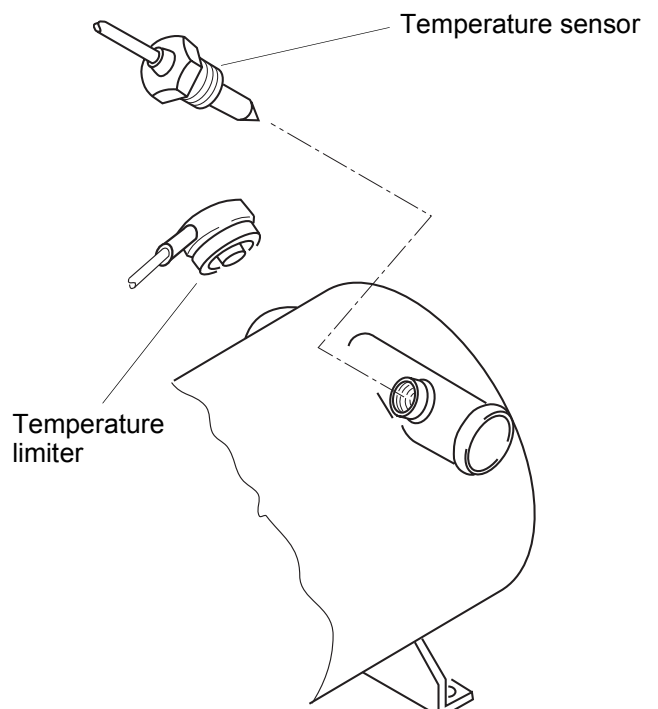

2.10 Overheat Thermostat for burner (Thermo 231 and 301 only)

The overheat thermostat is screwed onto the disk and electrically connected to the solenoid valve of the fuel pump. When the burner overheats the thermostat causes an error lockout.

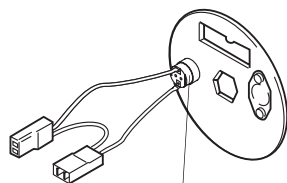

Overheat Thermostat

2.11 Circulation Pump

The externally mounted circulation pump ensures proper coolant circulation in the vehicle and heater circuit. The pump is activated by the control unit to operate as long as the heater is in operation. The heaters may be operated with circulation pump U 4814, Aquavent 5000 S, U 4851 or Aquavent 6000 S.

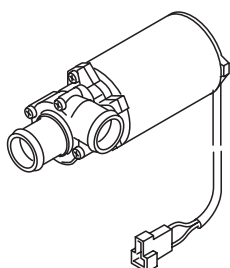

U 4814

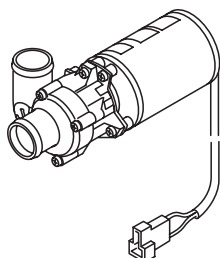

Aquavent 5000 S

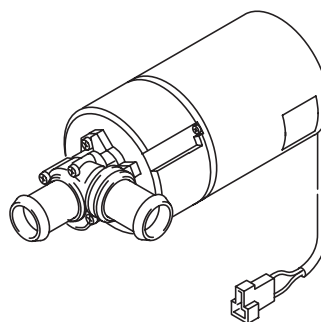

U 4851

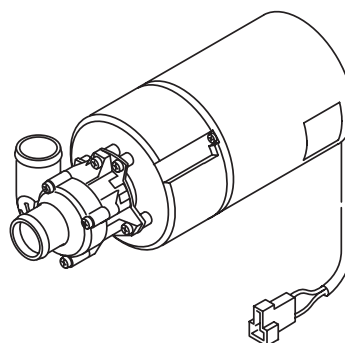

Aquavent 6000 S

2.11.1 Circulation Pump U 4851 and Aquavent 6000 S

The circulation pump U 4851 / Aquavent 6000 S is equipped with a brushless motor.

Soft start (U 4851 only)

Motor run-up is slow with no stress for the material. It takes 5 seconds to reach maximum speed.

Dry run protection

Integrated in the motor is a dry run protection for speeds > 3300 rpm.

If the motor in a time window of 1018 revolutions has a power consumption less than 4 A a dry run condition is identified. The motor is switched off by means of the failure mode (after approx. 10 seconds when in operation or approx. 15 seconds after activation).

Seizure protection

When operating speed drops below 57 rpm the motor is switched off after approx. 1 seconds by means of the failure mode.

If no complete revolution is achieved within 1 second with the motor powered, the motor is switched off by means of the failure mode.

Overload protection

After completion of the soft start an overload protection is activated to limit the power consumption and keep the speed at 5550 rpm. That means that the motor is not damaged in case of circulation pump hydraulic overpressure.

Failure mode

The failure mode stops the motor in case of malfunctions. After approx. 5 seconds the failure mode switches the motor to the power saving sleep mode.

Sleep mode

In the sleep mode the internal consumers of the motor electronics are switched off. The power consumption in this mode then amounts to < 2 mA.

Motor reactivation

The motor can be reactivated out of the sleep mode by disconnection of the power supply for approx. 2 minutes. After power reconnection the motor will again run up with a soft start.

Reverse pole protection

The motor **is not equipped with an internal reverse pole protection**. In combination with a wiring harness and a 25 A fuse the motor is protected against reverse poling.

2.12 Fuel Filter

In the case of compact units of the 230/300/350.126 Rail model range, a fuel filter is fitted that may be heated if desired. When the integrated filter heater is connected, the temperature switch will turn the filter heater on at a fuel temperature of $\leq 0.5 \pm 2.5$ °C and turn it off at $\geq 5.5 \pm 2.5$ °C.

3 Functional Description

Activation and deactivation is by means of a

- switch
- timer
- air conditioning

dependent on the type of installation.

For monitoring operation at least an operating indicator light is provided.

Switch off releases a run-down procedure (see "Switch off").

The heaters may be

- operated with power save for reduced fuel consumption (see circuit diagram)
- equipped or retrofitted with a nozzle block preheater for extreme low temperatures.

Heaters with control unit 1572D only

When connecting terminal +61 the heaters may operate in the auxiliary heating mode of operation.

Operating Thresholds

Control Unit	Ident. No. 63482E Ident. No. 97806B Bus	Ident. No. 97810A Rail Standard	Ident. No. 63859D Bahn J.E.S	Ident. No. 67981C Bahn Vossloh
Auxiliary heating				
Upper operating point	85°C	85°C	85°C	80°C
Lower operating point	78°C	70°C	75°C	72°C
Parking heating, normal				
Upper operating point	85°C	60°C	85°C	75°C
Lower operating point	70°C	45°C	70°C	60°C
Parking heating, economy				
Upper operating point	70°C	20°C	70°C	57°C
Lower operating point	55°C	5°C	55°C	42°C
Gradient evaluation	YES	YES	YES	YES
Hysteresis adaptation	YES	YES	YES	YES

3.1 Switch On

Upon switch on the operating indicator light goes on. Combustion air fan, fuel pump and circulation pump start operation. (If fitted and temperature is $< 0^{\circ}\text{C}$ nozzle block preheater is also activated).

After approximately 12 seconds (run-up time) the high voltage igniter spark is available. Approximately 1 second later the solenoid valve in the fuel pump opens and the nozzle sprays fuel into the combustion chamber to be ignited by the igniter spark. A photo control circuit deactivates the igniter box after flame-up.

3.2 Heating Operation

After reaching operating temperature the control unit takes over to provide controlled operation by activation and deactivation of the burner in order to maintain a nearly constant temperature of the heat exchanger (coolant).

The heating operation is terminated as soon as the upper operating point is exceeded. The heater now starts the control idle period. Heater operation is resumed when the temperature drops below the lower operating point.

Heaters with control unit 1572D only Gradient evaluation

With a low coolant flow rate or poor venting, the temperature in the heating mode rises too quickly. If gradient evaluation is available, the control unit is able to detect any undue temperature rise and can automatically shift the upper operating point to a lower value. Any tripping of the temperature limiter due to residual heat after the combustion operation has been terminated can thus be prevented.

Control idle period

A rise in temperature above the upper operating point makes the solenoid valve in the fuel pump shut off the fuel supply initiating the run-down. The flame extinguishes, the combustion air fan and the circulation pump however continue their operation. After approximately 90 seconds (120 seconds for heaters with control unit 1572D) run-down is completed with deactivation of the combustion air fan.

The circulation pump remains in operation during the control idle period. The operating indicator light is on.

3.3 Switch Off

Switching off the heater stops combustion. The operating indicator light goes out and run-down commences. The combustion air fan and circulation pump are deactivated after approximately 90 to 120 seconds (120 seconds for

heaters with control unit 1572D).

Reactivation of the heater during run-down is permitted. The burner immediately resumes operation after the run-up time.

3.4 Power Save

With power save on the control temperatures of the heating circuit are kept low. Combustion performance is not reduced.

This results in a reduced heat radiation loss when limited heating performance is required (e.g. in heat hold operation) cutting down fuel consumption.

3.5 Auxiliary Heating Operation (heaters with control unit 1572D only)

If terminal +61 (engine running) is connected and active, the heater will be operating in the auxiliary heating mode. In the auxiliary heating mode, the economy setting is deactivated automatically by the control unit.

The lower temperature threshold for restarting the burner after the control idle period is here higher than in the parking heating mode and is shifted automatically up or down depending on the combustion time of the heater (hysteresis adaptation).

Hysteresis adaptation (example)

After the first control idle period, the lower operating point is 78°C .

Combustion operation is started when the temperature falls below this threshold.

The length of combustion time until the upper operating point is exceeded should be 120 seconds.

If combustion lasts more than 120 seconds, the lower operating point is increased by 1 Kelvin, up to max. 80°C . If combustion time is less than 120 seconds, the lower operating point is lowered by 1 Kelvin, down to minimally 70°C .

3.6 Heater Lockout (heaters with control unit 1572D only)

After the heater has performed eight consecutive start attempts due to a malfunction or after five consecutive subsequent flame-outs the heater enters a lockout and start attempts are suspended. This lockout is superior to the normal error lockout. Unlocking is performed by starting the heater and disconnection of the main power supply of the heater during error run-down.

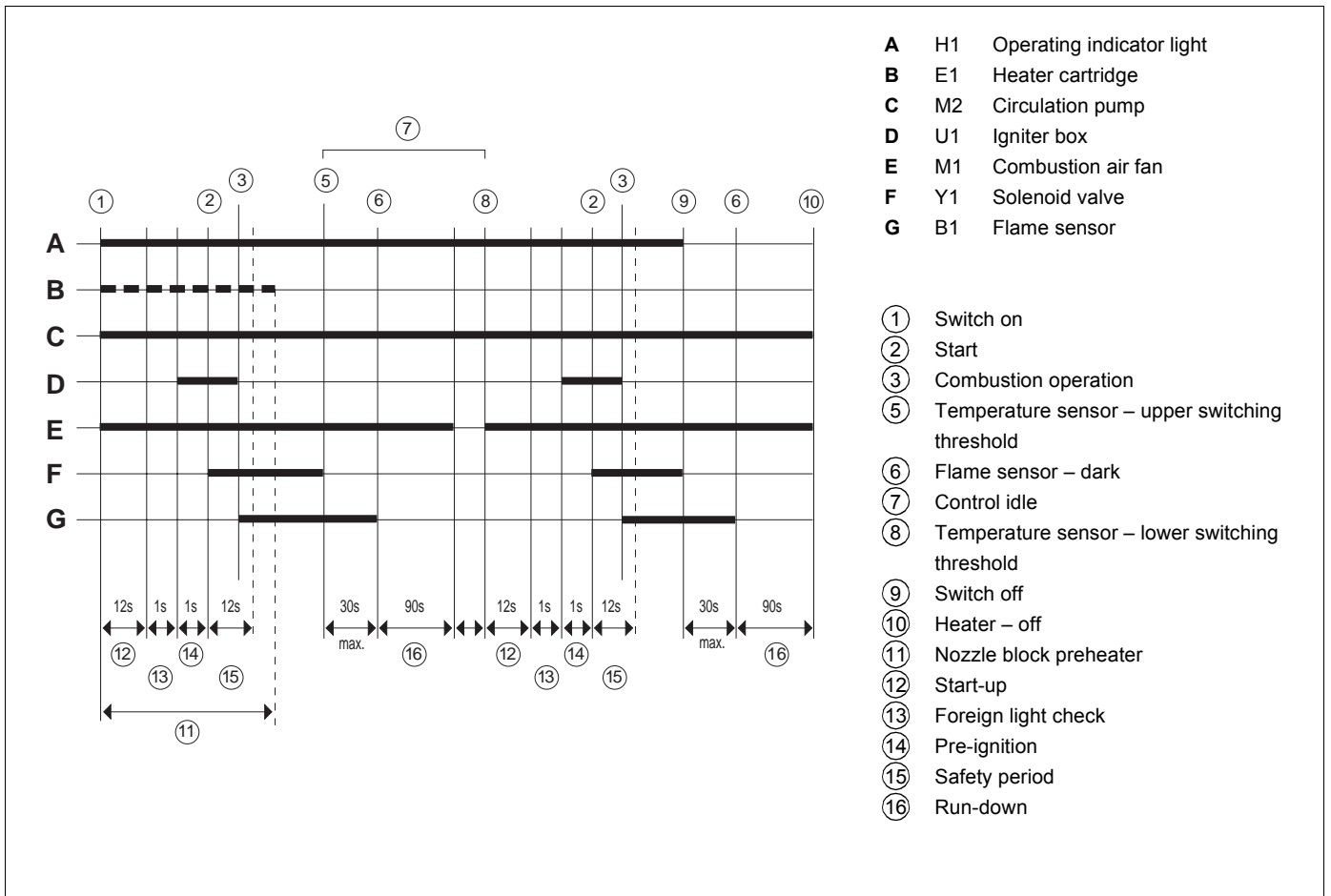

Fig. 301 Functional Sequence (heaters with control unit 1572)

3.7 Switch-off upon Failure (heaters with control unit 1572)

The heater switches off automatically when detecting one of the following malfunctions.

The operating indicator light goes off. Combustion air fan and circulation pump are deactivated after approximately 90 to 120 seconds.

Malfunctions during switch-on

- short or open circuit of temperature sensor.
- short or open circuit of flame sensor.
- open circuit of solenoid valve.

Malfunctions during start-up:

- flame detected by photo control circuit prior to high voltage igniter spark.
- no flame detected after approximately 25 seconds after heater start.

Malfunctions during heating operation:

- low voltage threshold of approximately 20V violated for a duration of 12 seconds.
- no combustion for more than 10 seconds.

- temperature sensor short or open circuit.
- temperature sensor short or open circuit during combustion.
- flame sensor short or open circuit during combustion.
- solenoid valve short or open circuit during combustion.

Malfunctions during run-down:

Detection of a flame after more than 30 seconds after start of run-down with the circulation pump and combustion air fan maintaining operation for the following 90 seconds.

Malfunctions by overheating:

Overheating results in deactivation of the heater by the temperature limiter. After the heater has cooled down and the cause of overheating has been corrected, the temperature limiter must be reset by pressing the reset button.

An error reset for a new start standby is achieved by switching the heater off and on again.

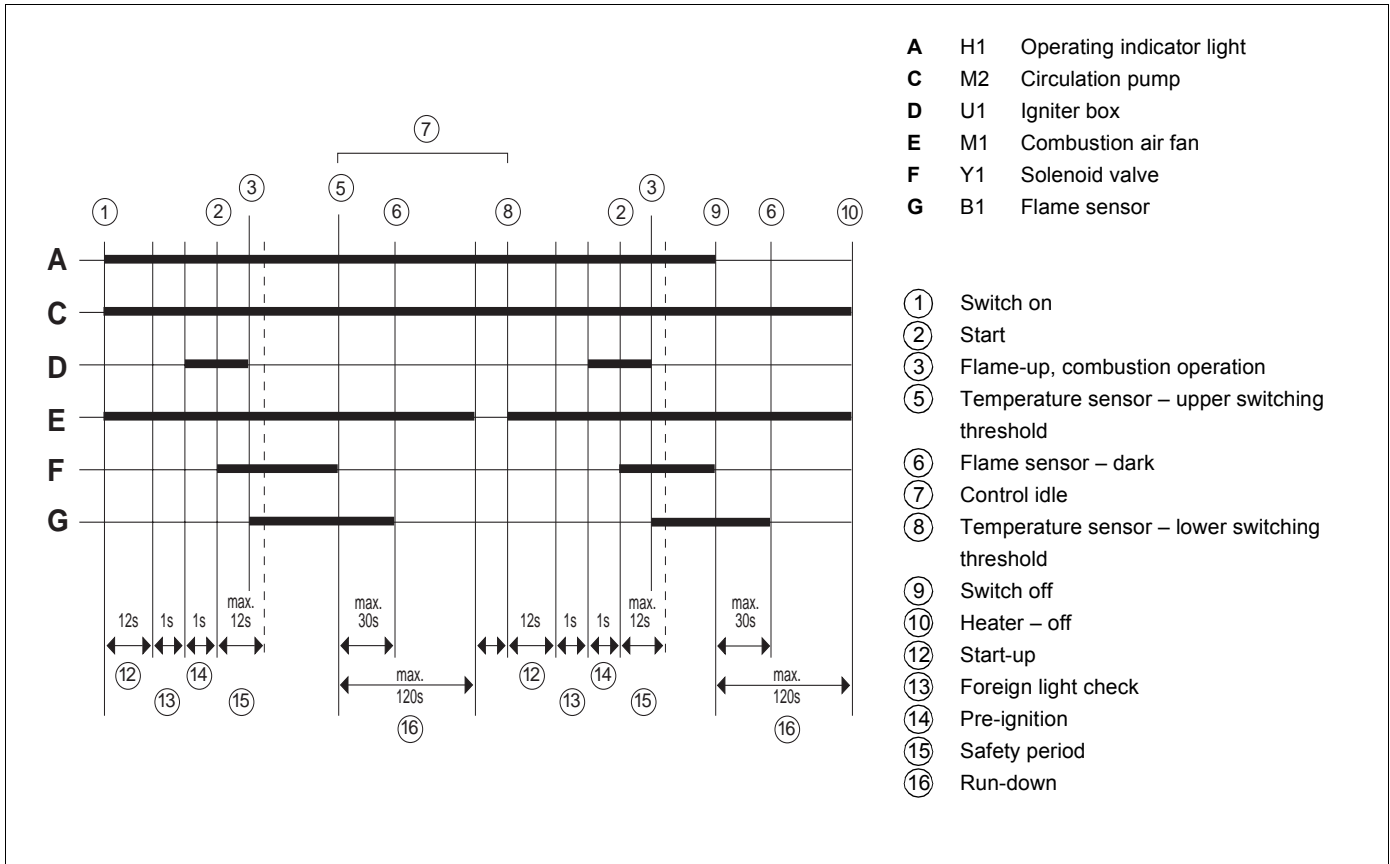

Fig. 302 Functional Sequence (heaters with control unit 1572D)

3.8 Switch-off upon Failure (heaters with control unit 1572D)

The heater switches off automatically when detecting one of the following malfunctions.

Several subsequent switch-offs due to a malfunction will cause the heater to enter an error lockout condition.

Flash pulses are output via the operating indicator light. The combustion air fan and the circulation pump are switched off after approx. 120 seconds.

Malfunctions during switch-on:

- Short or open circuit of
 - temperature sensor
 - flame sensor
 - burner motor
 - solenoid valve
 - igniter box

Malfunctions during start-up:

- short circuit of igniter box
- open circuit of igniter box
- flame detected by photo control circuit prior to high voltage igniter spark.
- no flame detected after approximately 25 seconds after heater start.

- short/open circuit or dry run (if programmed) of circulation pump. when using the circulation pump U 4851 approximately 15 seconds after switch-on the circulation pump is automatically stopped and may only be reactivated after approximately 2 minutes should coolant be missing or the pump wheel be seized.

Malfunctions during heating operation:

- low voltage threshold of approximately 21 V violated for a duration of 20 seconds.
- no combustion for more than 10 seconds.
- temperature sensor short or open circuit.
- flame sensor short or open circuit.
- solenoid valve short or open circuit.

Malfunctions during run-down:

Detection of a flame after more than 30 seconds after start of run-down with the circulation pump and combustion air fan only maintaining operation for the following 90 seconds.

Malfunctions by overheating:

Overheating results in deactivation of the heater by the temperature limiter. Dependent on heater configuration:

- the reset button on the temperature limiter must be reset.
- the reset is performed automatically after cool down.

An error reset for a new start standby is achieved by switching the heater off and on again.

Malfunctions by overheating of the burner (Thermo 231 and 301):

Overheating of the burner causes the overheat thermostat to initiate an error lockout at 150° C.

The solenoid valve closes, the fuel supply is cut off and a run-down is launched. An auto-reset occurs after cool-down of the thermostat.

3.9 Error Code Output (heaters with control unit 1572D)

When equipped with a standard timer an error code readout appears on the display of the timer after a malfunction.

NOTE

When the heater is operated by means of a switch the type of error is output during heater run-down via a flash code of the operating indicator light. After five short signals the long flash pulses are counted. The flash pulses correspond to the error number in the table below:

- F 01 no start
- F 02 flame failure *
- F 03 low voltage or excess voltage
- F 04 foreign light detected during run-up and run-down
- F 05 flame sensor defective
- F 06 temperature sensor defective
- F 07 solenoid valve defective
- F 08 fan motor defective
- F 09 circulation pump defective
- F 10 temperature limiter defective / overheating
- F 11 igniter box defective
- F 12 error lockout due to repeated malfunction or repeated flame failure (8x no start-up or 5x flame failure)

* A response of the overheat thermostat will be stored in the control unit as a flame-out (F 02) (*Thermo 231 and 301*).

4 Technical Data

Where no threshold values are specified technical data are understood to include standard tolerances for heater units of $\pm 10\%$ at ambient temperature of $+ 20^\circ \text{C}$ and at nominal voltage.

Electrical components

Control unit, fan and circulation pump motors, solenoid valve, igniter box, heater cartridge for nozzle block pre-heater and timer are 24 V components. Temperature limiter, flame sensor, temperature sensor and switches are voltage independent components.

NOTE

The allocation of circulation pumps to heater units must be in accordance with coolant resistances.

Propellant

The suitable propellant is the Diesel fuel specified by the vehicle manufacturer.

Only the type of fuel indicated on the identification plate may be used. Also Diesel fuel with an addition of 5% PME (vegetable oil methyl ester), class EL fuel oils (not fuel oil L) or petroleum may be used if their quality is in accordance with the German standard.

A bad influence caused by additives is not known.

When using fuel out of the vehicle tank the information about additives of the vehicle manufacturer must be observed.

When using fuel out of a separate fuel tank and at temperatures below 0°C , winter Diesel fuel must be used. The use of flow improvers is permitted.

Mixing ratio for separate fuel tank and temperature below 0°C .

Temperature	Winter Diesel fuel	Additive petroleum or petrol
0°C to -20°C	100 %	—
-20°C to -30°C	70 %	30 %
	or special low temperature Diesel fuel	
-30°C to -40°C	special low temperature Diesel fuel or 100 % petroleum	

Circulation pump		Thermo 230	Thermo 231	Thermo 300	Thermo 301	Thermo 350
Type		DW 230	Thermo 231	DW 300	Thermo 301	DW 350
Mark of conformity up to 4/03		~ S230	~ S327	~ S229	~ S328	~ S228
EC type approval number	e1*2001/56*	0007*--	0010*--	0008*--	0011*--	0009*--
Heater principle		High pressure atomizer				
Heating flow	KW (kcal/h)	23 (20 000)		30 (26 000)		35 (30 000)
Fuel		Diesel / fuel oil				
Fuel consumption	kg/h	2.5		3.3		3.7
Nominal voltage	V-	24				
Operating voltage	V-	20 ... 28				
Nominal power consumption (without circulation pump)	W	65		110		140
Permissible operating ambient temperature range (heater, control unit, circulation pump)	°C	-40 ... +85				
Permissible storage temperature	°C	+110 max.				
Permissible operating overpressure	bar	0.4 ... 2.0				
Heat exchanger capacity	l	1.8				
Minimum capacity of circuit	l	10.00				
CO ₂ in exhaust at nominal voltage	Vol.-%	10 ±0.5 related to 500 m above S.L.				
Dimensions heater (tolerance ± 3 mm)	mm mm mm	Length 610 Width 246 Height 220				
Weight	kg	19				

Circulation pump		U 4814	Aquavent 5000 S	U 4851	Aquavent 6000 S
Volume flow	l/h	5200 (against 0.15 bar)	5200 (against 0.4 bar)	6000 (against 0.4 bar)	6000 (against 0.4 bar)
Nominal voltage	V-	24			
Operating voltage range	V-	20 ... 28			
Nominal power consumption	W	104	215	209	209
Dimensions	mm	Lenght 221	Lenght 249	Lenght 279	Lenght 284
	mm	Width 100	Width 100	Width 115	Width 115
	mm	Height 105	Height 105	Height 110	Height 110
Weight	kg	2.1	4.75	2.7	2.95

Optional Fuel Filter Heater

Filter Heater		
Nominal power consumption	W	240
Nominal voltage	V -	24
Switch-on point	C°	0,5 ± 2,5
Switch-off point	C°	5,5 ± 2,5

5 Troubleshooting

5.1 General

This section describes troubleshooting procedures for the heaters *Thermo 230, 231, 300, 301* and *350*.

CAUTION

Troubleshooting requires profound knowledge about components and their theory of operation and may only be performed by trained personnel.

In case of doubt functional interrelations may be derived from Sections 2 and 3.

CAUTION

Troubleshooting is normally limited to the isolation of defective components. The following possible causes for trouble have not been taken into consideration and must always be excluded as a possible cause for malfunction:

- corrosion on connector**
- loose contact on connector**
- wrong crimping on connector**
- corrosion on wiring and fuses**
- corrosion on battery terminals**

After any fault correction a functional checkout in the vehicle has to be performed.

5.2 General Fault Symptoms

The following table (Fig. 501) lists possible fault symptoms of general nature.

Symptom	Probable Cause
<p>Fault in electrical system</p> <p>Operating indicator light is not on, no heater operation.</p> <p>Fuse F2 blows.</p> <p>Fuse F3 blows.</p> <p>Normal heater operation, operating indicator light is out.</p>	<ul style="list-style-type: none"> • no power supply • fuses • wiring to terminals of connector A of control unit. <p>Short circuit in circulation pump or in wiring to heater.</p> <p>Short circuit in wiring to heater/motor/nozzle block preheater (if installed).</p> <p>Operating indicator light defective or wiring to light open or shorted.</p>
<p>Fault in water system</p> <p>Circulation pump not operating (U 4851 and Aquavent 6000 S only)</p>	<ul style="list-style-type: none"> • Failure mode activated <p>The failure mode switches the motor off in case of malfunctions. After approx. 5 sec the failure mode switches the motor to the power saving sleep mode.</p> <p>In the sleep mode the internal consumers of the motor electronics are switched off. The power consumption in this mode then amounts to < 2 mA.</p> <p>The motor can be reactivated out of the sleep mode by disconnection of the power supply for approx. 2 minutes. After power reconnection the motor will again run up with a soft start.</p>

Fig. 501 General Fault Symptoms (Sheet 1 of 3)

Symptom	Probable Cause
<p>Wrong combustion</p> <p>CO₂ value cannot be set to rated value, combustion irregular.</p>	<ul style="list-style-type: none"> • air bubbles in suction line (suction line leaking). • fuel filter contaminated or leaking. • fuel system integration leak (suction height, low pressure in tank); observe installation instructions. • fuel pump defective (pump pressure). • return line throttled. • filter screen in pump contaminated. • O-ring sealing on fuel pump no longer effective (ageing) • nozzle jet defective. • combustion air or exhaust lines throttled or closed. • fan motor speed too low.

Fig. 501 General Fault Symptoms (Sheet 3 of 3)

5.3 Fault Symptoms during Functional Checkouts and Error Code Output or Tests with Diagnostic Computer, Components Tester or PC Heater Diagnosis

Operation of the diagnostic computer is menu controlled by means of four push button switches.

For details refer to operating instructions for "Diagnostic Computer".

5.3.1 General

Components Tester

Error Code Output

NOTE

Checks with the components tester may only be performed on heaters equipped with control unit 1572.

NOTE

Only heaters with a control unit 1572D provide an error code output.
 When equipped with a standard timer an error code readout is available after a malfunction on the display of the timer.
 When the heater is operated by means of a switch a coded flashing of the operating indicator light during run-down of the heater or until switch-off indicates the type of error (see 3.9).

Using the components tester several types of faults and component malfunctions may be analyzed in the vehicle. The test of the individual components with the components tester is not intended. Faults like short or open circuits may be detected with the components tester but cannot be localized.

For details refer to operating instructions for "Components Tester".

Diagnostic Computer

PC Heater Diagnosis

NOTE

Checks with the diagnostic computer may only be performed on heaters equipped with control unit 1572.

By use of the PC heater diagnosis heaters (with control unit 1572 or 1572D) may be tested in the vehicle.

By use of the diagnostic computer heaters may be checked in the vehicle. The following tests are available:

For details refer to operating instructions for "PC Heater Diagnosis".

- indication of measured values: water temperature, control unit supply voltage, flame sensor bright/dark.
- indication and erasure of faults stored in the control unit.

5.3.2 Fault Symptoms

5.3.2.1 Fault Symptom "No Start"

NOTE

Heaters with control unit 1572D:
If the heater performs 8 consecutive attempts to start due

to a malfunction, the heater enters an error lockout and stops any further attempts to start. This error lockout is superior to the normal error lockout condition. The error lockout reset is achieved by switching the heater on and disconnection of the heater power supply during run-down.

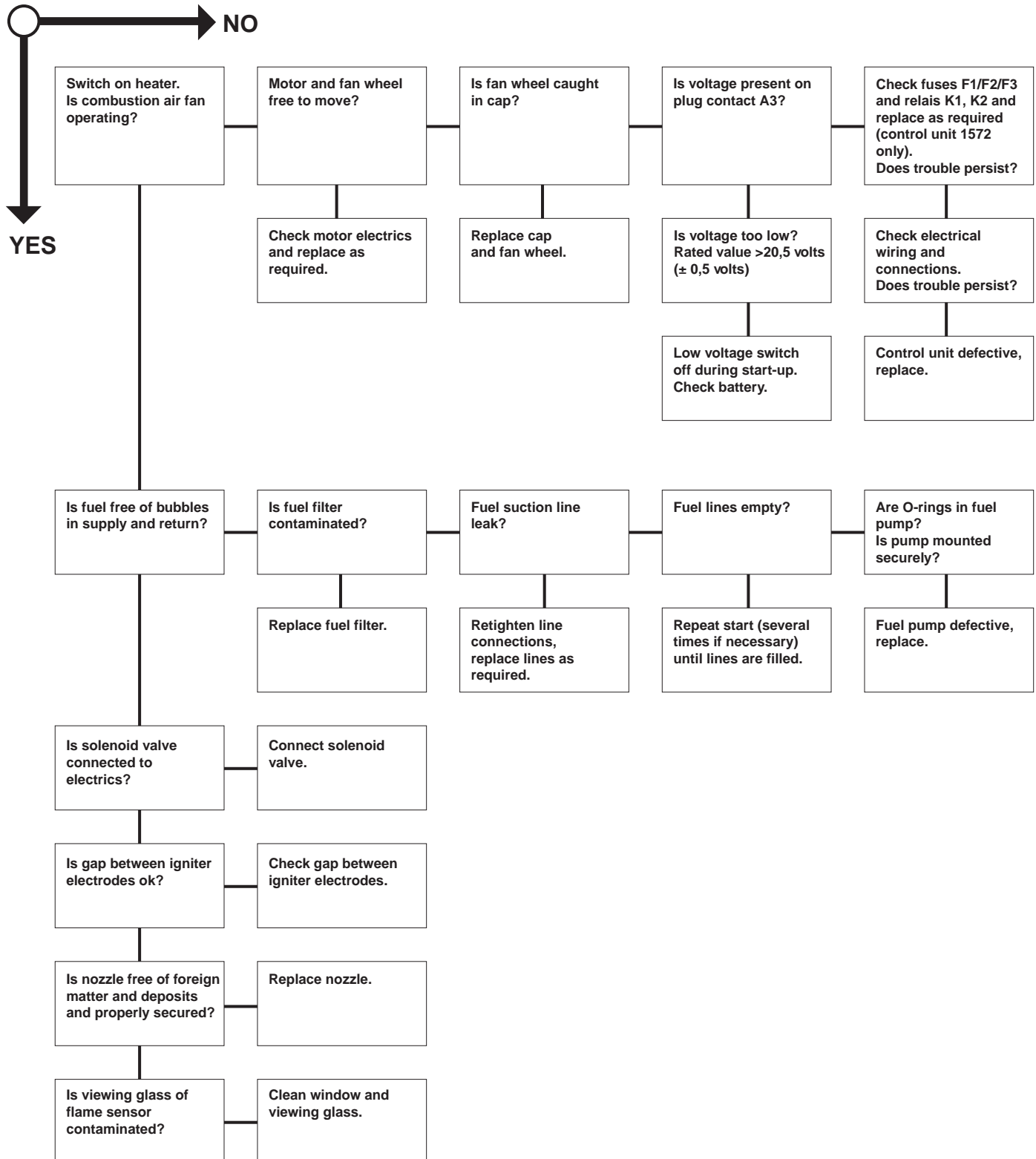

5.3.2.2 Fault Symptom "Flame-out"

NOTE

Heaters with control unit 1572D:
 If the heater performs 5 consecutive attempts to start due to a malfunction, the heater enters an error lockout and

stops any further attempts to start. This error lockout is superior to the normal error lockout condition. The error lockout reset is achieved by switching the heater on and disconnection of the heater power supply during run-down.

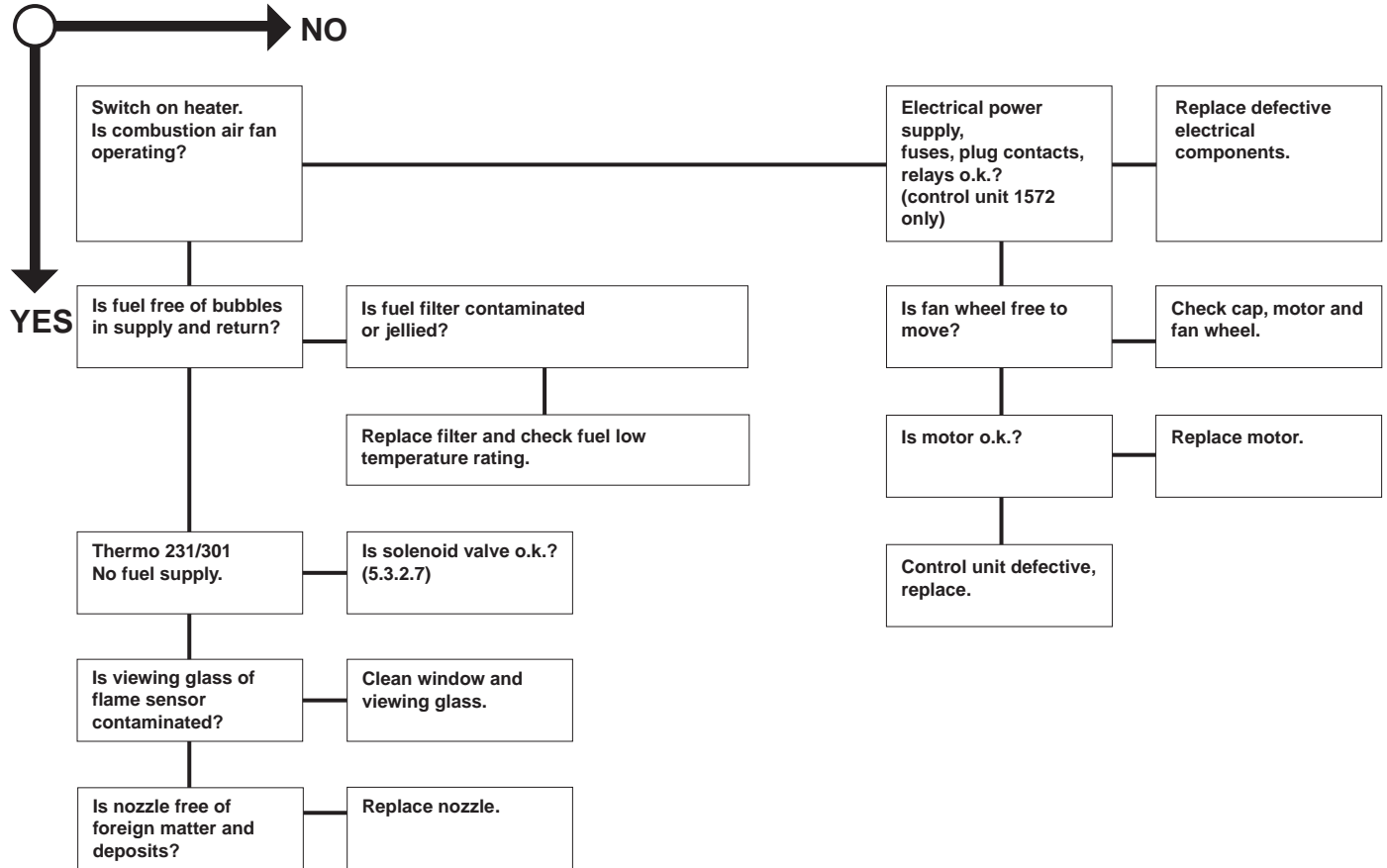

5.3.2.3 Fault Symptom "Low Voltage"

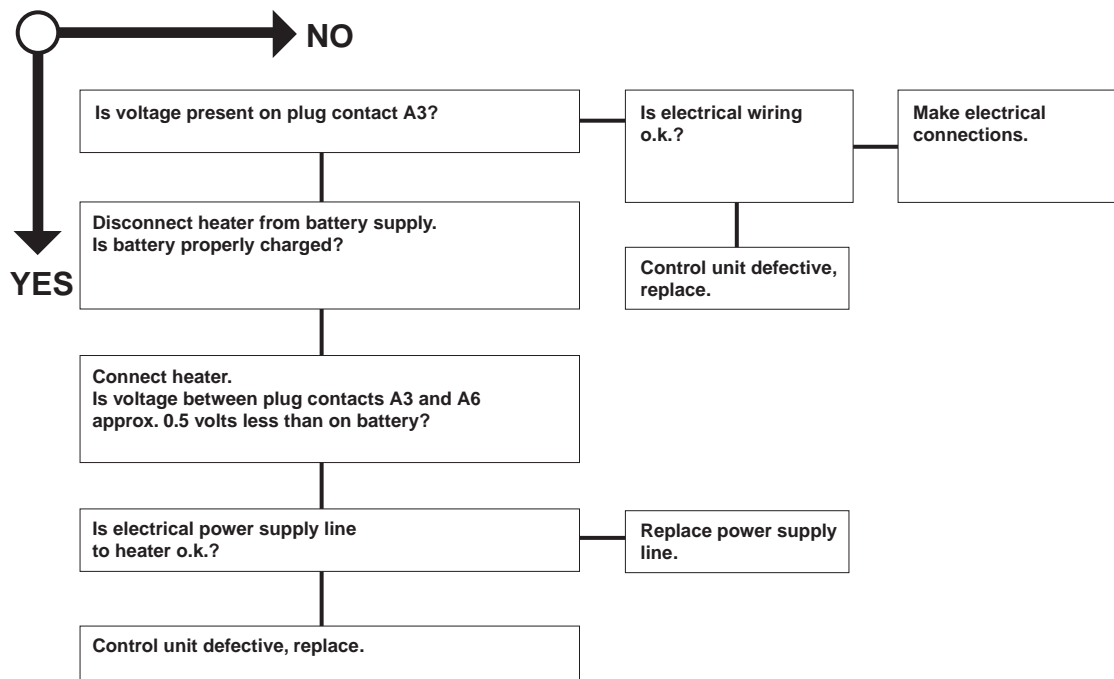

5.3.2.4 Fault Symptom "Foreign Light Detection during Run-up or Run-down"

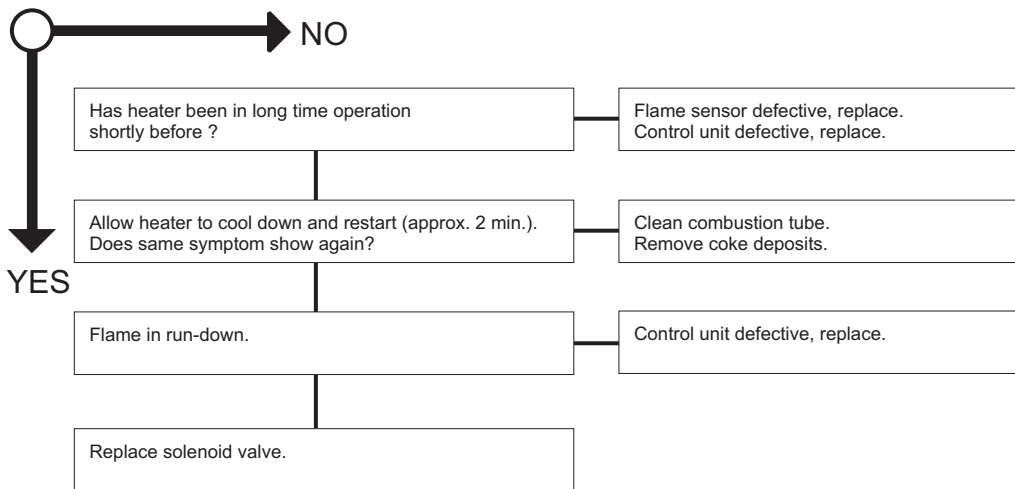

5.3.2.5 Fault Symptom "Flame Sensor Defective"

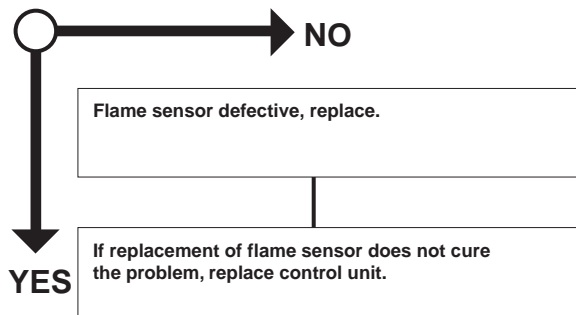

5.3.2.6 Fault Symptom "Temperature Sensor Defective"

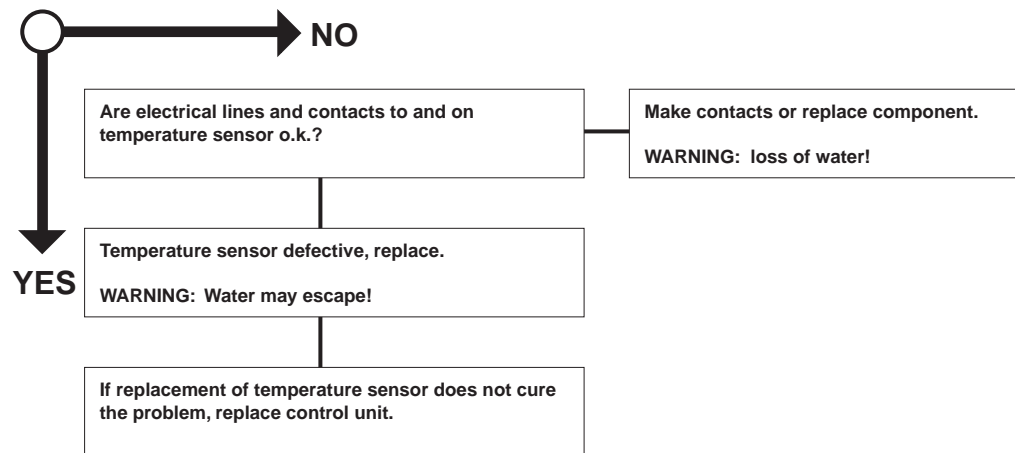

5.3.2.7 Fault Symptom "Solenoid Valve Defective"

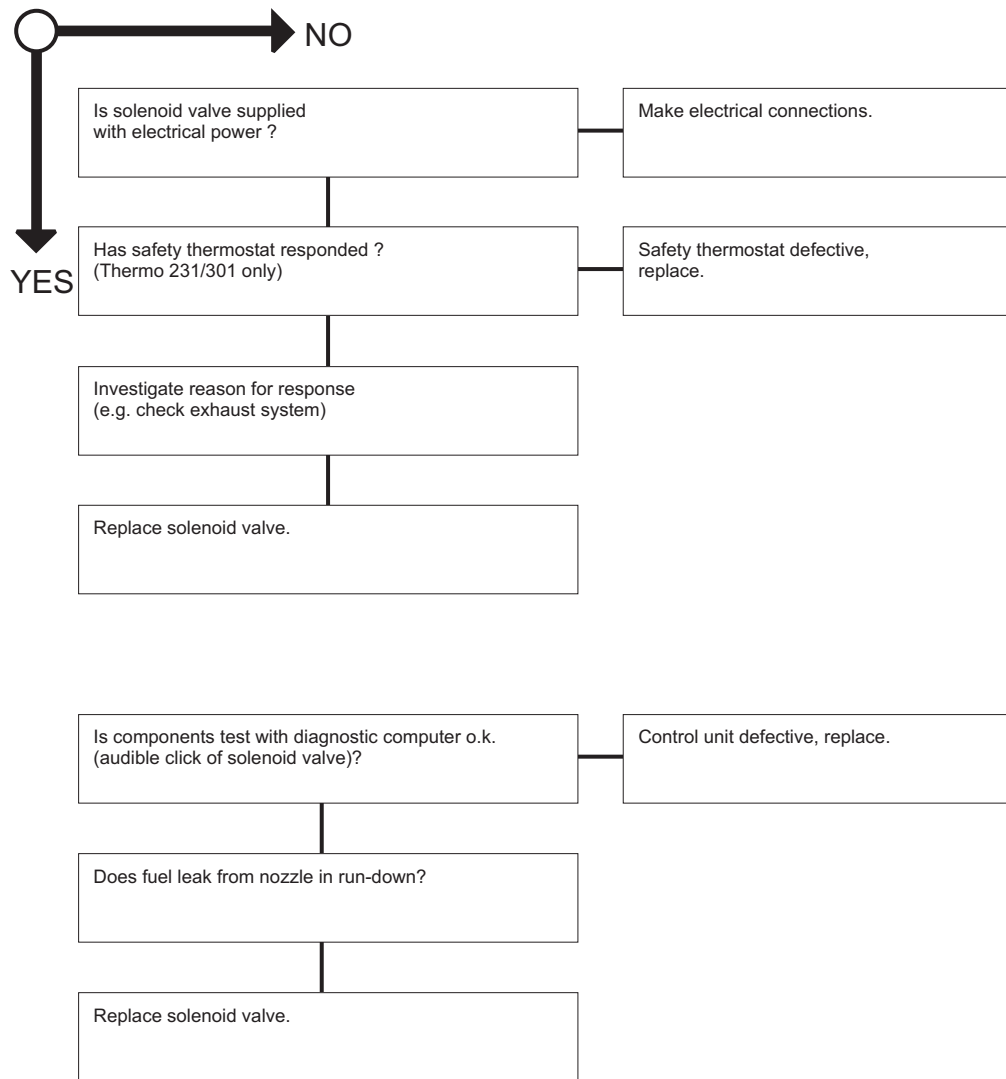

5.3.2.8 Fault Symptom "Temperature Limiter Defective"

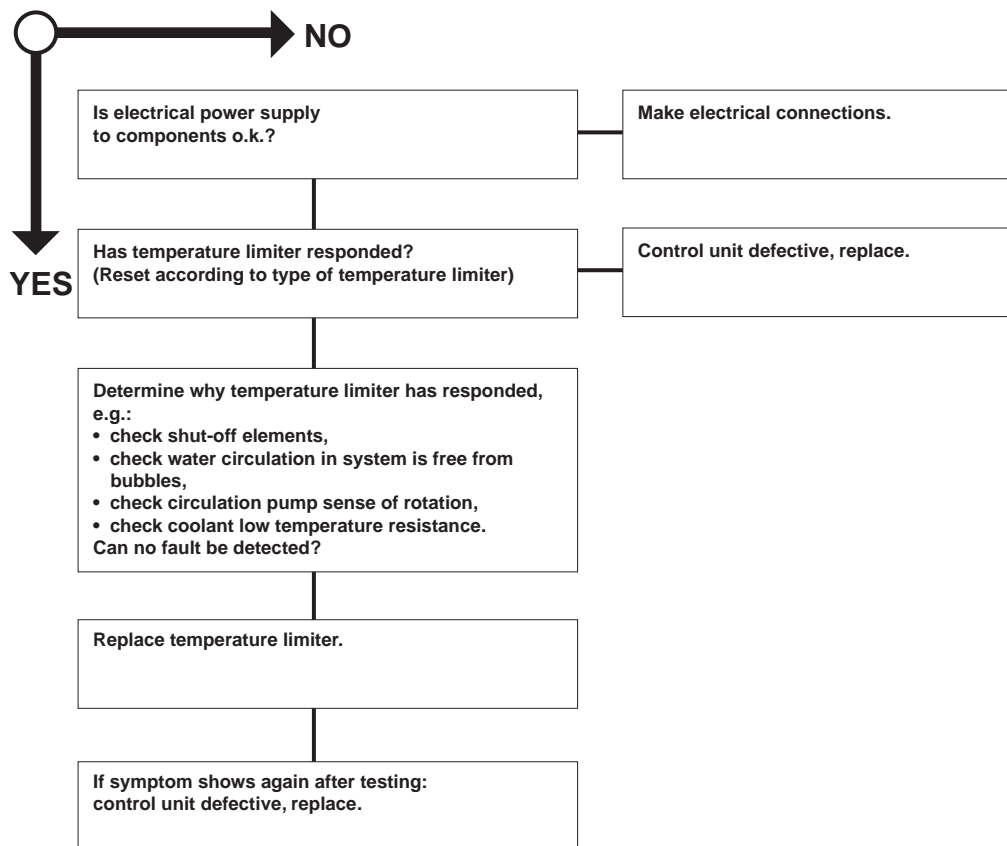

6 Functional Checkouts

6.1 General

This section describes the tests and adjustments on the heater in installed and removed condition to prove its serviceability.

WARNING

The heater must not be operated in closed areas like garages or workshops with no exhaust ventilation facilities.

To prevent fires do not switch heater on with burner swung open.

6.2 Adjustments

6.2.1 Adjustment of CO₂ Contents

It is allowed to change the manufacturer's setting for combustion air quantity by rotation of the setting ring.

Measurement of the CO₂ value of the exhaust gas must be performed followed by an adjustment of the combustion air quantity as required in case of:

- repairs on the burner
- irregularities in combustion
- functional checkouts
- nozzle replacement

Setting procedure

- measure control unit power supply voltage
- operate heater for approximately 5 min.
- measure CO₂ contents and smoke spot number and compare with relevant diagram

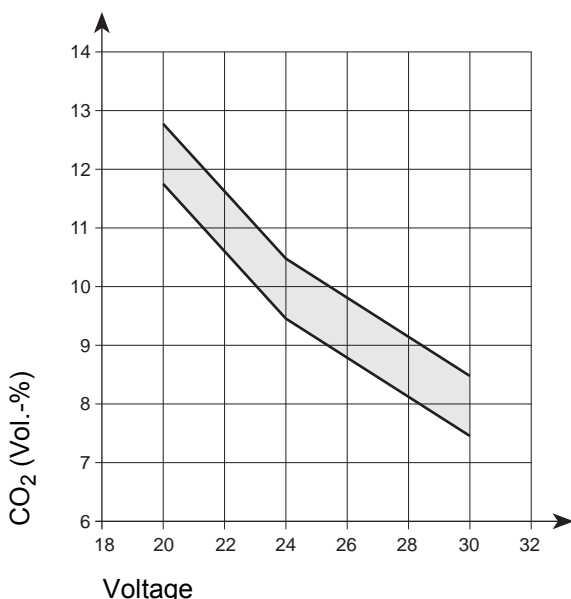

CO₂ - setting at 500 m NN

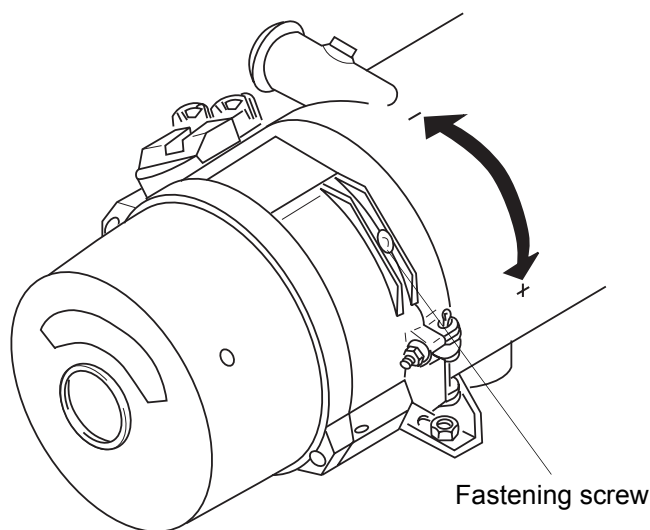

- loosen fastening screw (refer to Fig.) and reposition setting ring with fastening screw until rated value is obtained.
- tighten fastening screw with 1.0 +0.5 Nm and apply screw seal varnish.

NOTE

CO₂ setting depends on fuel (viscosity) and on geodetic altitude (0.1 % per 100 m).

If proper setting cannot be obtained or when exceeding smoke spot number, proceed as follows:

- check burner head air side for damage and replace if required
- check fuel pump pressure and replace pump if required
- check fuel filter and strainer in fuel pump for contamination and replace if required
- adjust pressure
- replace fuel nozzle
- measure burner motor speed

6.3 Components Testing

6.3.1 Temperature Sensor Resistance Check

When checking the temperature sensor with a digital multimeter the values of the following diagram must be obtained. Resistance checking is preferably performed at ambient temperatures between 20° C and approximately 100° C (immerse sensor in water).

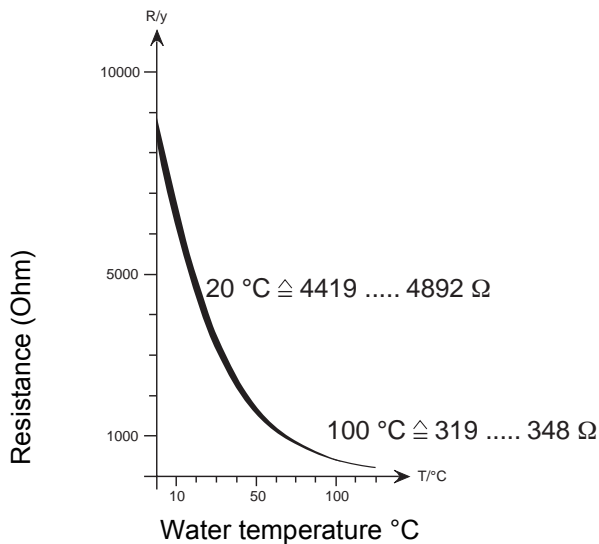

6.3.2 Flame Sensor Resistance Check

NOTE

The glass bulb of the flame sensor and the viewing glass of the window (refer to Fig.) are to be cleaned if contaminated. In case of damage or not obtaining the rated values replace flame sensor.

Check

- cover flame sensor glass bulb
- check resistance (rated value: < 20 kOhm)
- uncover flame sensor glass bulb and expose to light of strong lamp.
- check resistance (rated value: < 400 Ohm)

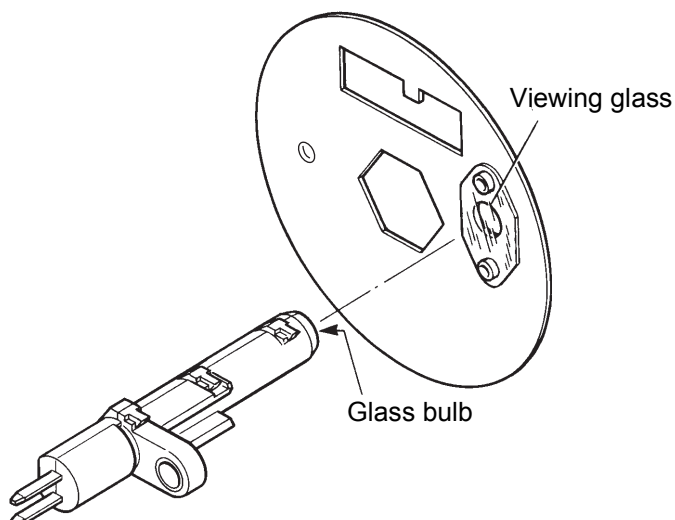

6.3.3 Igniter Electrodes Check

NOTE

The insulator of the igniter electrodes must show no damage. Igniter electrodes not working properly must be replaced.

Check

- inspect insulators of igniter electrodes for damage

6.3.4 Igniter Box Check

NOTE

The igniter box may also be tested using the PC heater diagnosis (component test).

WARNING

High voltage; 20.000 volts arcing across the igniter electrodes.

CAUTION

Do not apply voltage to igniter box without electrodes.

Check

- apply 24 V as shown on figure
- normal condition: spark between electrodes.

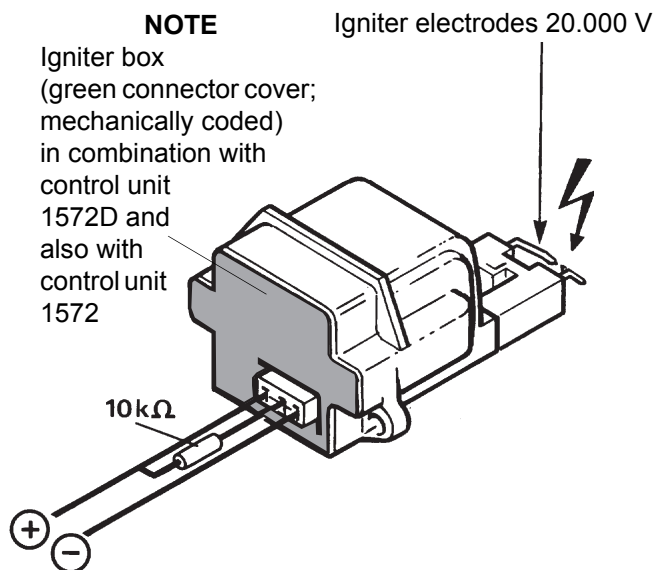
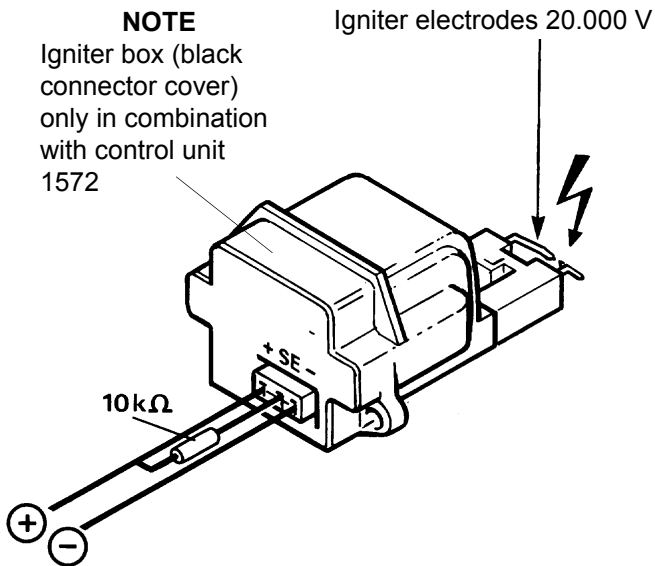

6.3.5 Fuel Pump Check

6.3.5.1 Fuel Pump Check on Heaters with Control Unit 1572

A test gauge is required for performing the test. Such a gauge (with a range from 0 to 15 bar) can be procured from your authorized Webasto dealer. The fuel pump and the fuel hoses must be replaced every 5 years.

CAUTION

The electronic ignition coil must be removed for safety reasons.

Check

- remove igniter box (refer to 9.2.7.1).
- remove nozzle.
- screw on tester.
- cover flame sensor.
- switch on heater.
- after approximately 13 sec. pump pressure is indicated (refer to diagram).
- switch off heater.
- unscrew tester.

CAUTION

Do not damage nozzle bore.

- screw in nozzle and torque with 20 Nm.
- install igniter box (refer to 9.2.7.2).

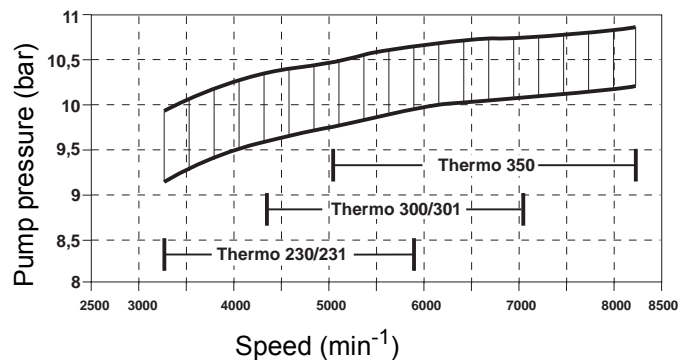
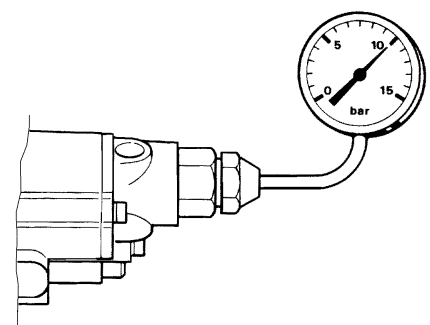

Pump pressure in relation to speed

6.3.5.2 Fuel Pump Check on Heaters with Control Unit 1572D

NOTE

On heaters with control unit 1572D the fuel pump may only be checked by means of the PC heater diagnosis. The fuel pump and the fuel hoses must be replaced every 5 years.

6.3.6 Fan Motor Check

NOTE

The fan motor check is performed with the burner installed. If normal conditions are not obtained the fan motor must be replaced.

Check

- check fan motor bearing condition(binding)
 - measure heater power supply voltage
 - switch on heater
 - measure speed and compare with the diagram below
- | | | |
|----------------|-----------|---------|
| Thermo 230/231 | 4400 ±350 | 24 Volt |
| Thermo 300/301 | 5200 ±420 | 24 Volt |
| Thermo 230 | 6200 ±500 | 24 Volt |

6.3.7 Solenoid Valve Check

NOTE

A solenoid valve leaking valve seat shows by rather long smoke emissions during run-down. In this case fuel keeps dripping through the fuel nozzle. Short smoke emissions are normal caused by clearing the area between solenoid valve and nozzle bore.

Check

CAUTION

Disconnect solenoid valve connector from control unit to avoid damage to the control unit.

- Check electrics for the following values:
 - break voltage 17.0 Volts
 - operating voltage 19.2 ... 28.8 Volts
 - power consumption at nominal voltage and 20° C 10 Watts
 - nominal current 0.42 Amps

NOTE

With all variants of the control unit the solenoid valve may also be checked by means of the PC heater diagnosis (component test).

6.3.8 Nozzle Block Preheater Check

NOTE

At a temperature of < 0° C the heater cartridge in the nozzle block is activated. The heating period depends on the heat reflected within the combustion chamber. Preheating is deactivated when the thermostat ambient temperature is +8° C. Power consumption is 130 ±13 Watts at 24 Volt.

Check

- swing burner head open or remove
- disconnect electrical connector
- connect ohmmeter to connector
- using cooling spray cool down thermostat or bridge
- resistance (max. 4.5 Ω).

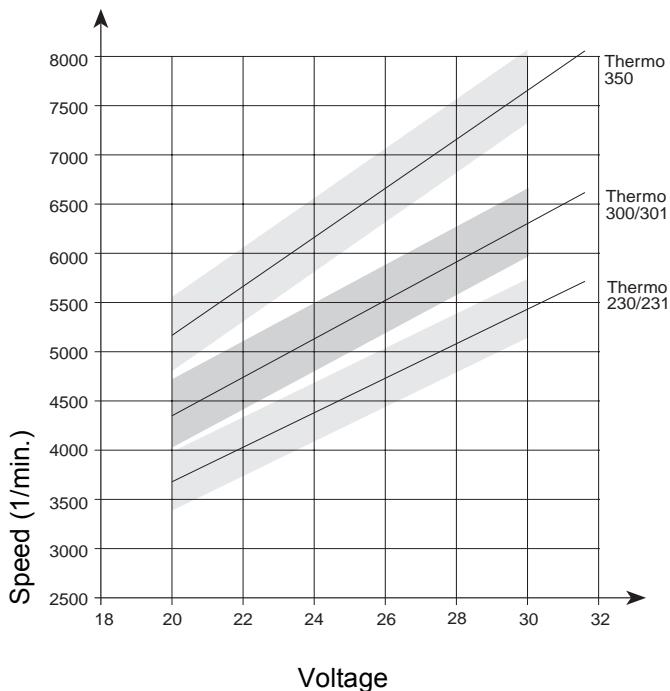

7 Circuit Diagrams

7.1 General

The circuit diagrams (Fig. 701 and 702) show possible heater circuits for *Thermo 230, 300* and *350* with control unit 1572 and with

- switch
- timer 1529 (triple timer)

The circuit diagrams (Fig. 703 and 704) show possible heater circuits for *Thermo 230, 231, 300, 301* and *350* with control unit 1572D and with

- switch
- standard timer 1531

The circuit diagrams (Fig. 705 through 710) show possible variants of heater circuits for *Thermo 230, 231, 300, 301* and *350* with control unit 1572D.

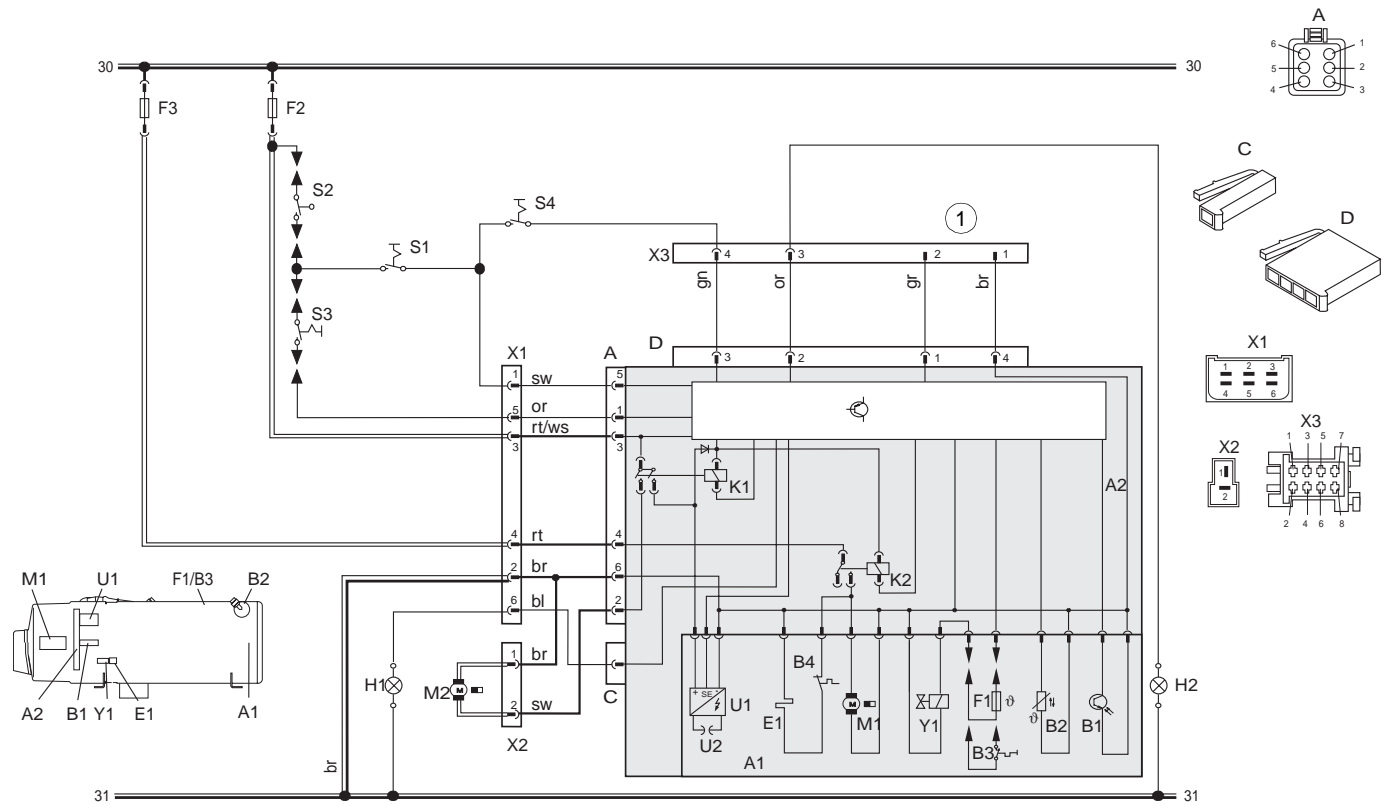

① Diagnostic connector

Wire colors	
bl	blue
br	brown
ge	yellow
gn	green
gr	gray
or	orange
rt	red
sw	black
vi	violet
ws	white

Wire gauges		
	< 7.5 m	7.5 - 15 m
	0.75 mm ²	1.5 mm ²
	1.0 mm ²	1.5 mm ²
	1.5 mm ²	2.5 mm ²
	2.5 mm ²	4.0 mm ²
	4.0 mm ²	6.0 mm ²

Item	Nomenclature	Remark
A1	Heater	not grounded
A2	Control unit	SG 1572
B1	Flame sensor	
B2	Temperature sensor	
B3	Temperature limiter	
B4	Thermostat	open at T > 8 °C
E1	Heating cartridge	for nozzle preheating
F2	Fuse 25A	flat fuse SAE J 1284
F3	Fuse 25A	flat fuse SAE J 1284
H1	Light	operation indicator light
K1	Relay (in item A2)	for circulation pump
K2	Relay (in item A2)	for combustion air fan / heating cartridge
M1	Motor	combustion air fan
M2	Motor	circulation pump
S1	Switch	on / off
S2	Continuity switch	on water cock

Item	Nomenclature	Remark
S3	Switch, external trigger circulation pump	
S4	Switch	power save operation
U1	Igniter box	
U2	Igniter electrodes	
A	Plug connections, 6-pole	
C	Plug connections, 1-pole	
D	Plug connections, 4-pole	
X1	Plug connections, 6-pole	
X2	Plug connections, 2-pole	
X3	Plug connections, 8-pole	
Y1	Solenoid valve	

Fig. 701 Automatic Control Circuit with Control Unit 1572 and Switch

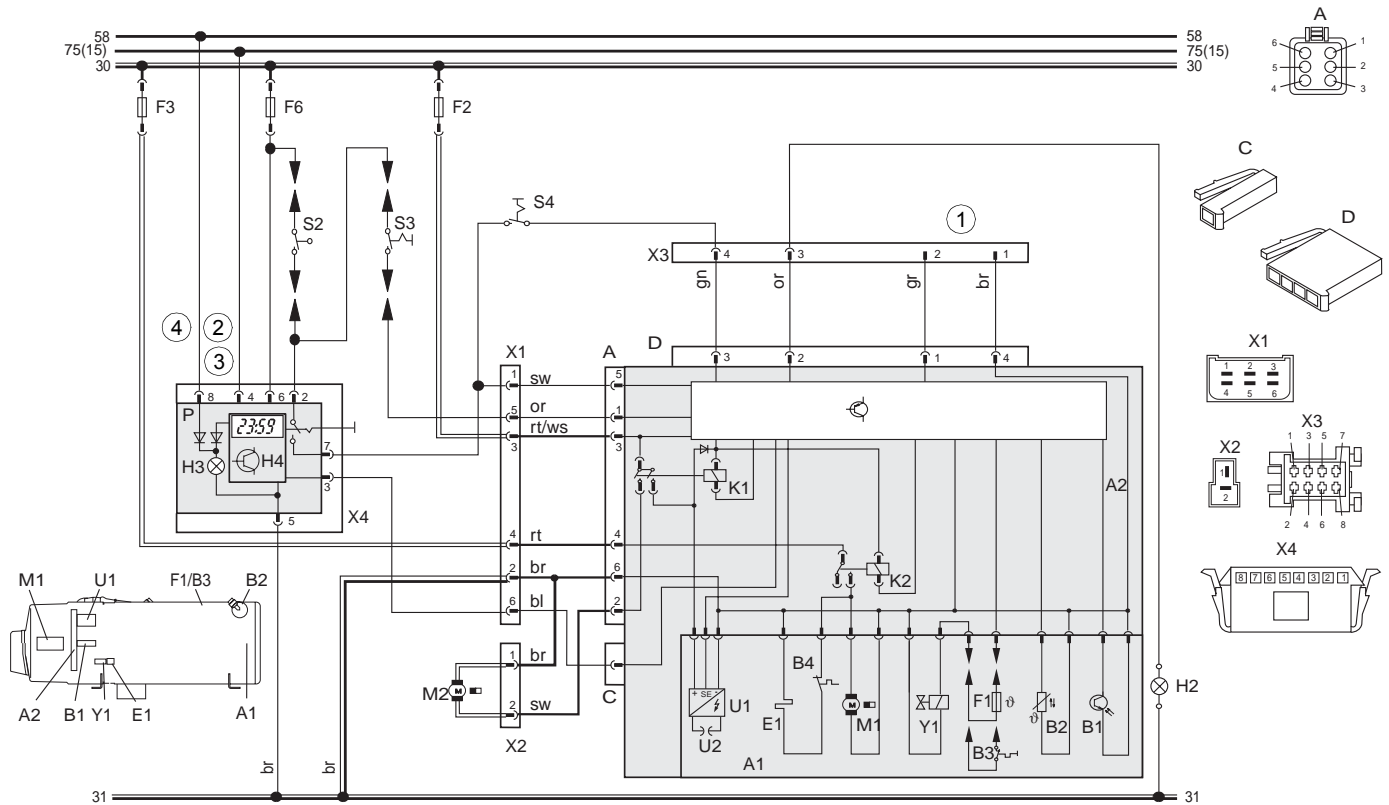

- ① Diagnostic connector
- ② to vehicle terminal +75 if available, otherwise terminal 15
- ③ Timer P:
with plus to connection 4 = continuous operation during immediate heating
without plus to connection 4 = heating period 1 hour
- ④ vehicle lighting terminal 58

Wire gauges		
	< 7.5 m	7.5 - 15 m
—	0.75 mm ²	1.5 mm ²
—	1.0 mm ²	1.5 mm ²
—	1.5 mm ²	2.5 mm ²
—	2.5 mm ²	4.0 mm ²
—	4.0 mm ²	6.0 mm ²

Wire colors	
bl	blue
br	brown
ge	yellow
gn	green
gr	gray
or	orange
rt	red
sw	black
vi	violet
ws	white

Item	Nomenclature	Remark
A1	Heater	not grounded
A2	Control unit	SG 1572
B1	Flame sensor	
B2	Temperature sensor	
B3	Temperature limiter	
B4	Thermostat	opens at T > 8 °C
E1	Heating cartridge	for nozzle preheating
F2	Fuse 25A	flat fuse SAE J 1284
F3	Fuse 25A	flat fuse SAE J 1284
F6	Fuse 5A	flat fuse SAE J 1284
H3	Light in item P	symbol lighting
H4	Symbol for "Heating" in Display	symbol lighting (in item P)
K1	Relay (in item A2)	for circulation pump
K2	Relay (in item A2)	fo combustion air fan / heating cartridge
M1	Motor	combustion air fan
M2	Motor	circulation pump
P	Triple timing clock (1529)	for timed operation

Item	Nomenclature	Remark
S2	Continuity switch	on water cock
S3	Switch, external trigger circulation pump	
S4	Switch	power save operation
U1	Igniter box	
U2	Igniter electrodes	
A	Plug connections, 6-pole	
C	Plug connections, 1-pole	
D	Plug connections, 4-pole	
X1	Plug connections, 6-pole	
X2	Plug connections, 2-pole	
X3	Plug connections, 8-pole	
X4	Plug connections, 8-pole	
Y1	Solenoid valve	

Fig. 702 Automatic Control Circuit with Control Unit 1572 and Timer (Triple Timer)

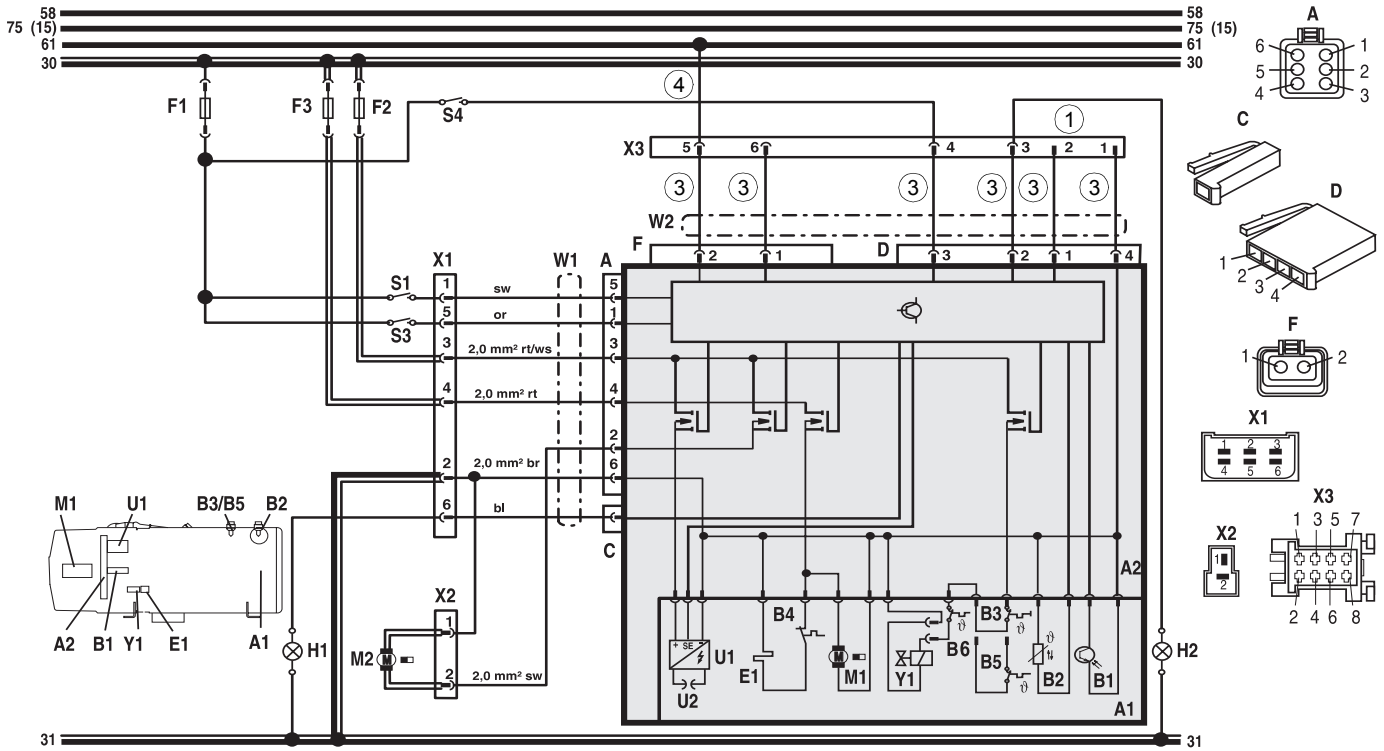

① Diagnostic connector

③ Pin assignment:

Pin assignment	4wire lead	7wire lead
D1	0,75 gr	0,75 rt
D2	0,75 or	0,75 or
D3	0,75 gn	0,75 bl
D4	0,75 br	2,0 br
F1	nicht belegt	2,0 sw
F2	nicht belegt	2,0 rt/ws

④ with connection to terminal 61 auxiliary

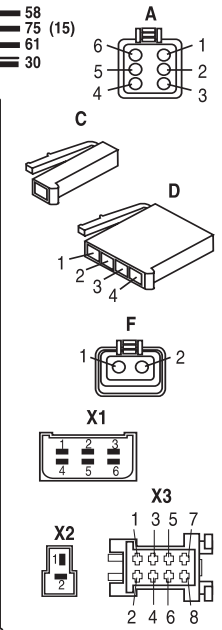

Wire colors	
bl	blue
br	brown
ge	yellow
gn	green
gr	gray
or	orange
rt	red
sw	black
vi	violet
ws	white

Wire gauges		
	< 7.5 m	7.5 - 15 m
	0.75 mm ²	1.5 mm ²
	1.0 mm ²	1.5 mm ²
	1.5 mm ²	2.5 mm ²
	2.5 mm ²	4.0 mm ²
	4.0 mm ²	6.0 mm ²

Item	Nomenclature	Remark
A1	Heater	
A2	Control unit	SG 1572D
B1	Flame sensor	observe polarity
B2	Temperature sensor	polarity optional
B3	Temperature limiter	
B4	Thermostat	for nozzle preheating
B5	Thermostat	alternative to B3
B6	Thermostat	for vertical installation (MV Y1)
E1	Heating cartridge	for nozzle preheating
F1	Fuse 5 A	flat fuse DIN 72581 part 3
F2	Fuse 25 A	flat fuse DIN 72581 part 3
F3	Fuse 25 A	flat fuse DIN 72581 part 3
H1	Light	operation indicator light
H2	Light	flame indicator
M1	Motor	combustion air fan
M2	Motor	circulation pump
S1	Switch	on / off
S3	Switch	external trigger circulation pump

Item	Nomenclature	Remark
S4	Switch	power save operation
U1	Igniter box	
U2	Igniter electrodes	
W1	Wiring harness (1)	
W2	Wiring harness (2)	
A	Plug connections, 6-pole	
C	Plug connections, 1-pole	
D	Plug connections, 4-pole	
F	Plug connections, 2-pole	
X1	Plug connections, 6-pole	
X2	Plug connections, 2-pole	
X3	Plug connections, 8-pole	
Y1	Solenoid valve	

Fig. 703 Automatic Control Circuit with Control Unit 1572D and Switch

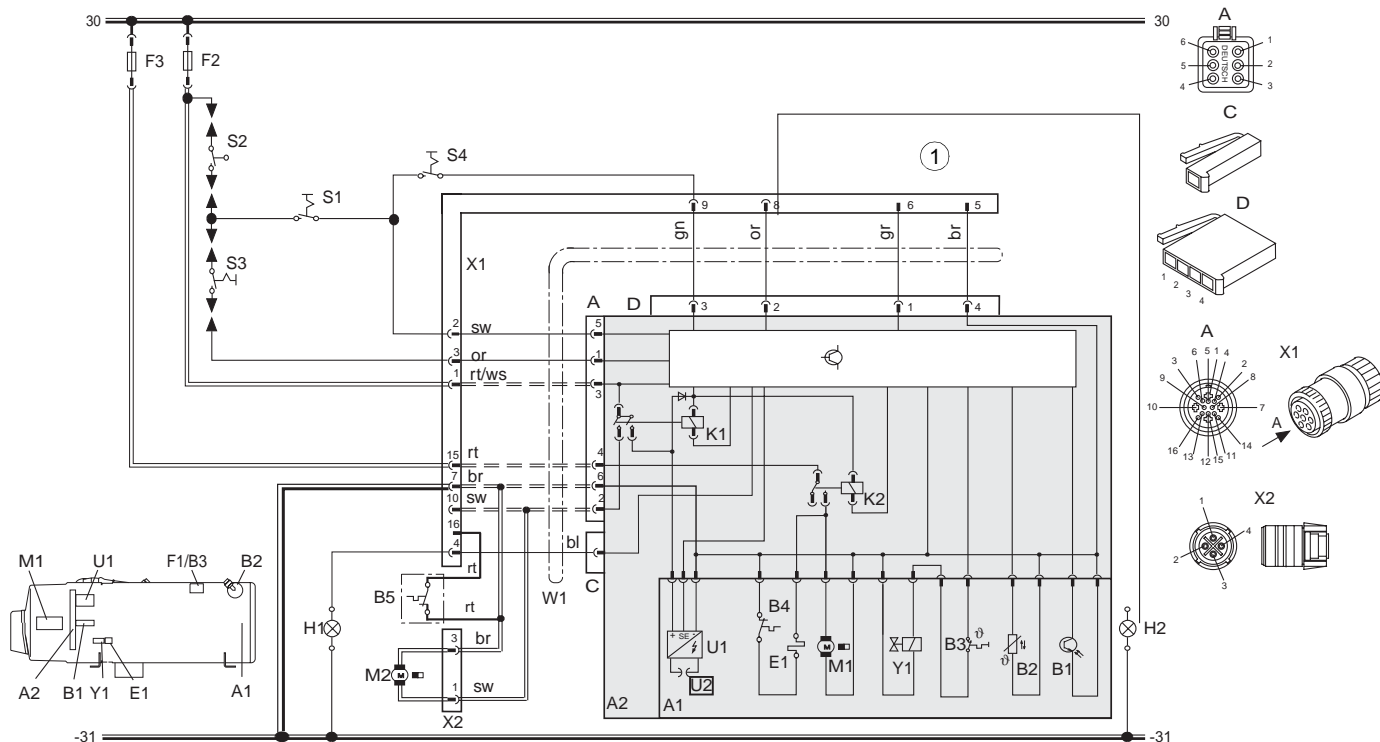

① Diagnostic connector

Fuse acc. to SAE J 1284 / DIN 72581			
	DW 230	DW 300	DW 350
F2	25A / 16A	25A / 16A	25A / 16A
F3	25A / 16A	25A / 16A	25A / 16A

Wire colors	
bl	blue
br	brown
ge	yellow
gn	green
gr	gray
or	orange
rt	red
sw	black
vi	violet
ws	white

Wire gauges		
	< 7,5 m	7,5 - 15 m
	0,75 mm ²	1,5 mm ²
	1,0 mm ²	1,5 mm ²
	1,5 mm ²	2,5 mm ²
	2,0 mm ²	? mm ²
	2,5 mm ²	4,0 mm ²
	4,0 mm ²	6,0 mm ²

Item	Nomenclature	Remark
A1	Heater	not grounded
A2	Control unit	SG 1572
B1	Flame sensor	observe polarity
B2	Temperature sensor	polarity optional
B3	Temperature limiter	alternative to F1
B4	Thermostat	for nozzle preheating
B5	Fire sensor	Van Hool
E1	Heating cartridge	
F2	Fuse	see table
F3	Fuse	see table
H1	Light	operation indicator light
H2	Light	flame indicator
K1	Relay (in item A2)	for circulation pump motor
K2	Relay (in item A2)	for combustion air fan
M1	Motor	combustion air fan
M2	Motor	circulation pump
S1	Switch	on / off
S2	Continuity switch	on water cock

Item	Nomenclature	Remark
S3	Switch, external trigger circulation pump	required, if S2 not installed
S4	Switch	power save operation
U1	Igniter box	
U2	Igniter electrodes	
W1	Wiring harness	Van Hool
A	Plug connections, 6-pole	
C	Plug connections, 1-pole	
D	Plug connections, 4-pole	
X1	Plug connections, 16-pole	
X2	Plug connections, 4-pole	
Y1	Solenoid valve	

Fig. 706 System Circuit Van Hool, Ident.-Nr. 89401

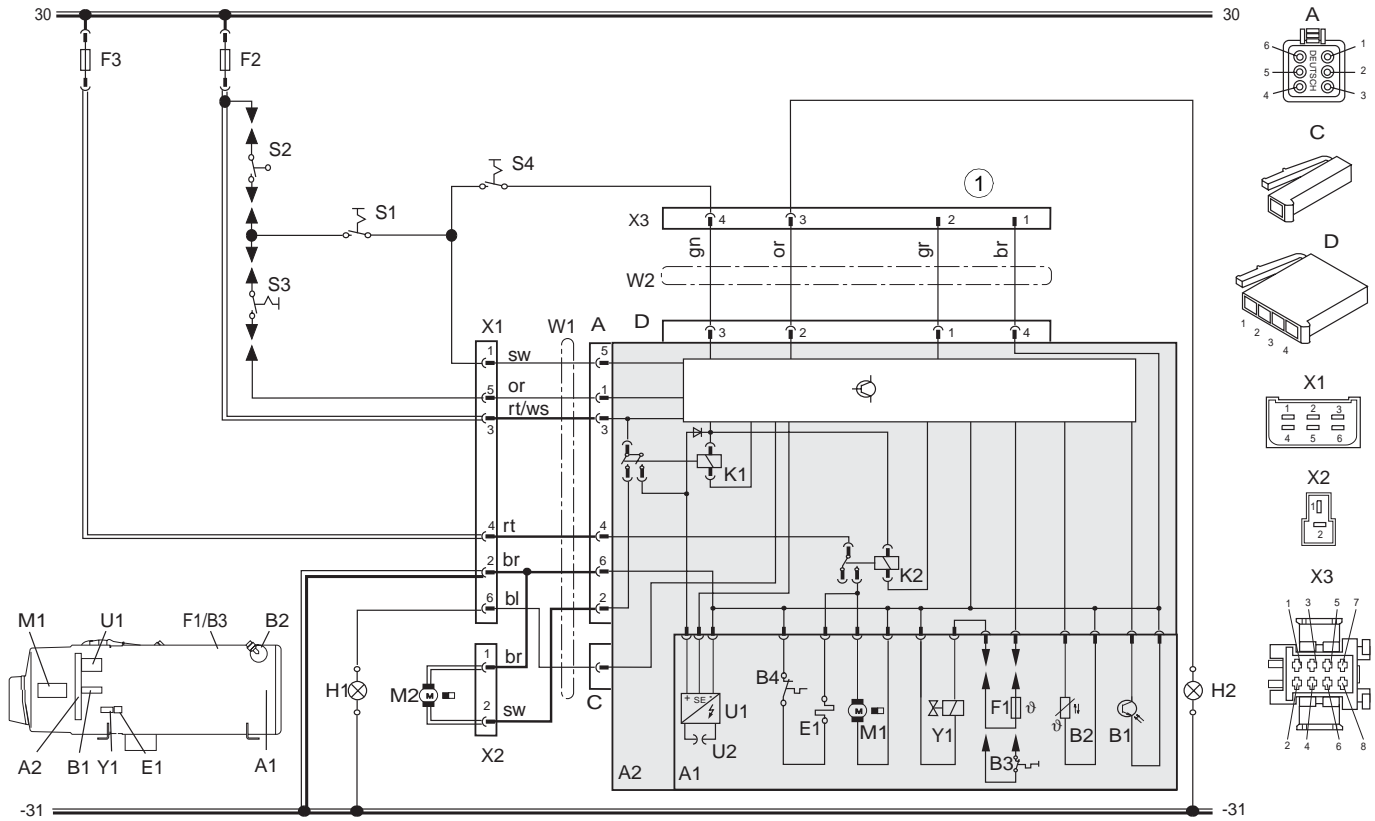

① Diagnostic connector

Fuse acc. to SAE J 1284 / DIN 72581			
	DW 230	DW 300	DW 350
F2	25A / 16A	25A / 16A	25A / 16A
F3	25A / 16A	25A / 16A	25A / 16A

Wire colors	
bl	blue
br	brown
ge	yellow
gn	green
gr	gray
or	orange
rt	red
sw	black
vi	violet
ws	white

Wire gauges		
	< 7,5 m	7,5 - 15 m
	0,75 mm ²	1,5 mm ²
	1,0 mm ²	1,5 mm ²
	1,5 mm ²	2,5 mm ²
	2,0 mm ²	? mm ²
	2,5 mm ²	4,0 mm ²
	4,0 mm ²	6,0 mm ²

Item	Nomenclature	Remark
A1	Heater	not grounded
A2	Control unit	SG 1572D
B1	Flame sensor	observe polarity
B2	Temperature sensor	polarity optional
B3	Temperature limiter	alternative to F1
B4	Thermostat	for nozzle preheating
E1	Heating cartridge	for nozzle preheating
F2	Fuse	see table
F3	Fuse	see table
H1	Light	operation indicator light
H2	Light	flame indicator
K1	Relay	for circulation pump motor
K2	Relay	for combustion air fan
M1	Motor	combustion air fan
M2	Motor	circulation pump
S1	Switch	on / off
S2	Continuity switch	on water cock

Item	Nomenclature	Remark
S3	Switch, external trigger circulation pump	required, if S2 not installed
S4	Switch	power save operation
U1	Igniter box	
U2	Igniter electrodes	
W1	Wiring harness (1)	
W2	Wiring harness (2)	
A	Plug connections, 6-pole	
C	Plug connections, 1-pole	
D	Plug connections, 4-pole	
X1	Plug connections, 6-pole	
X2	Plug connections, 2-pole	
X3	Plug connections, 8-pole	
Y1	Solenoid valve	

Fig. 707 System Circuit O405 / O407 / O408, Ident.-Nr. 91292

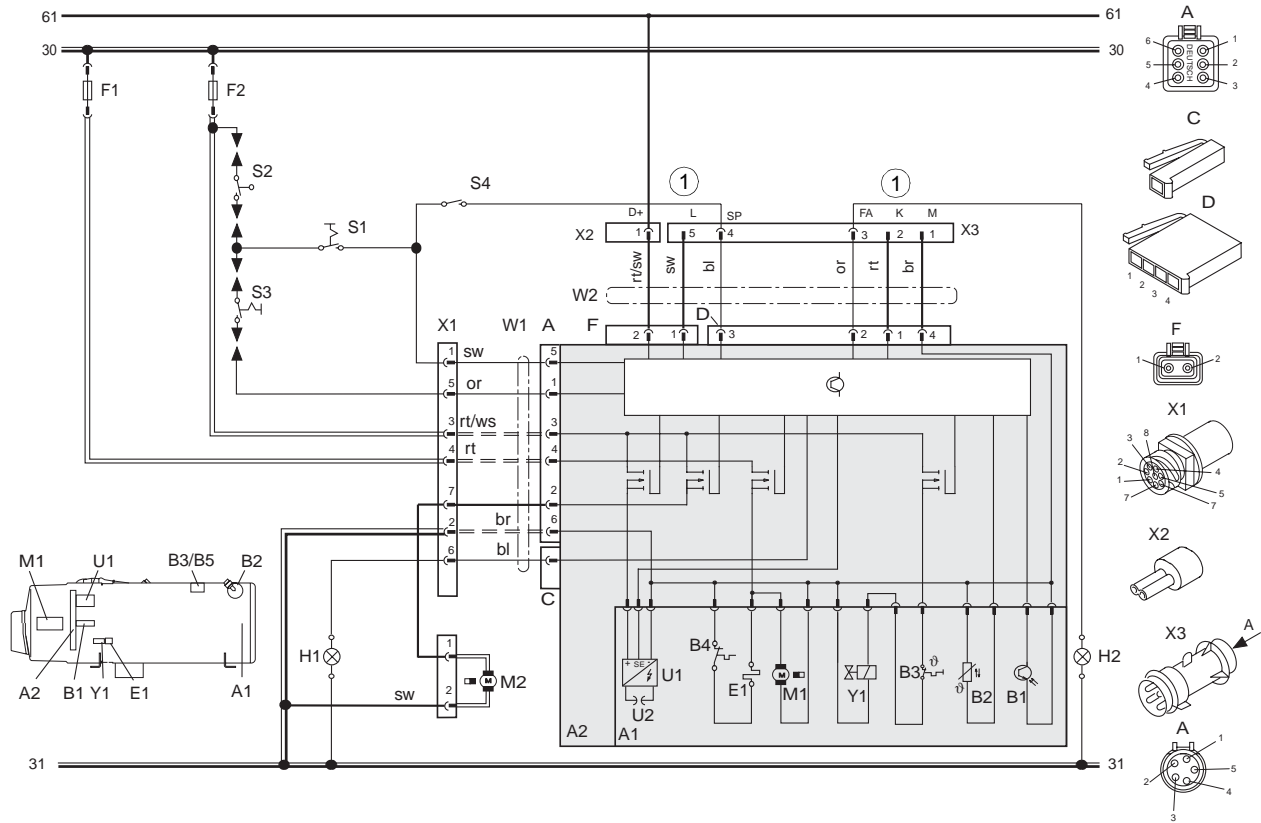

① Diagnostic connector

Wire gauges		
	< 7,5 m	7,5 - 15 m
	0,75 mm ²	1,5 mm ²
	1,0 mm ²	1,5 mm ²
	1,5 mm ²	2,5 mm ²
	2,0 mm ²	? mm ²
	2,5 mm ²	4,0 mm ²
	4,0 mm ²	6,0 mm ²

Wire colors	
bl	blue
br	brown
ge	yellow
gn	green
gr	gray
or	orange
rt	red
sw	black
vi	violet
ws	white

Item	Nomenclature	Remark
A1	Heater	not grounded
A2	Control unit	SG 1572D
B1	Flame sensor	observe polarity
B2	Temperature sensor	polarity optional
B3	Temperature limiter	
B4	Thermostat	for nozzle preheating
E1	Heating cartridge	for nozzle preheating
F2	Fuse 25 A	flat fuse DIN 72581 part 3
F3	Fuse 25 A	flat fuse DIN 72581 part 3
H1	Light	operation indicator light
H2	Light	flame indicator
M1	Motor	combustion air fan
M2	Motor	circulation pump
S1	Switch	on / off
S2	Continuity switch	on water cock
S3	Switch, external trigger circulation pump	required, if S2 not installed
S4	Switch	power save operation

Item	Nomenclature	Remark
U1	Igniter box	
U2	Igniter electrodes	
W1	Wiring harness (1)	
W2	Wiring harness (2)	
A	Plug connections, 6-pole	
C	Plug connections, 1-pole	
D	Plug connections, 4-pole	
F	Plug connections, 2-pole	
X1	Plug connections, 6-pole	
X2	Plug connections, 2-pole	
X3	Plug connections, 8-pole	
Y1	Solenoid valve	

Fig. 708 System Circuit MAN, Ident.-Nr. 89404

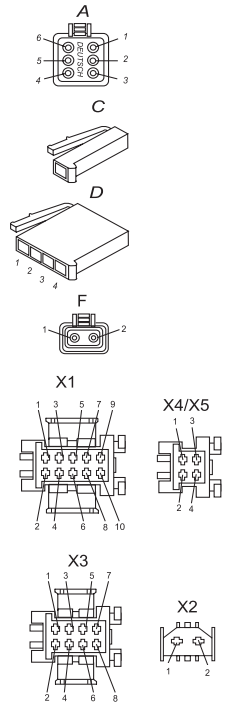
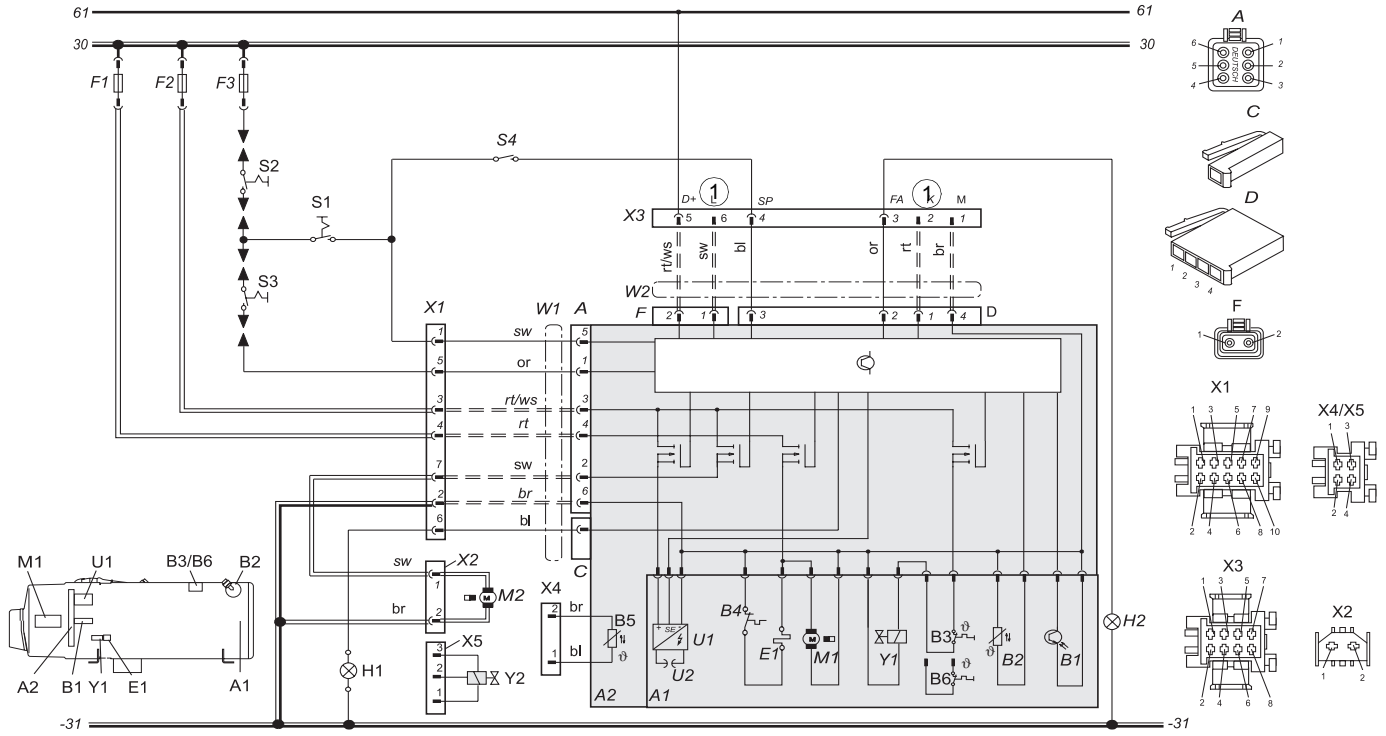

① Diagnostic connector

Wire colors	
bl	blue
br	brown
ge	yellow
gn	green
gr	gray
or	orange
rt	red
sw	black
vi	violet
ws	white

Wire gauges		
	< 7,5 m	7,5 - 15 m
	0,75 mm ²	1,5 mm ²
	1,0 mm ²	1,5 mm ²
	1,5 mm ²	2,5 mm ²
	2,0 mm ²	? mm ²
	2,5 mm ²	4,0 mm ²
	4,0 mm ²	6,0 mm ²

Item	Nomenclature	Remark
A1	Heater	not grounded
A2	Control unit	SG 1572D
B1	Flame sensor	observe polarity
B2	Temperature sensor	polarity optional
B3	Temperature limiter	
B4	Thermostat	for nozzle preheating
B5	Temperature sensor extern	observe polarity
B6	Thermostat	alternative to B3
E1	Heating cartridge	for nozzle preheating
F1	Fuse 25 A	flat fuse DIN 72581 part 3
F2	Fuse 25 A	flat fuse DIN 72581 part 3
F3	Fuse 5 A	flat fuse DIN 72581 part 3
H1	Light	operation indicator light
H2	Light	flame indicator
M1	Motor	combustion air fan
M2	Motor	circulation pump
S1	Switch	on / off
S2	Continuity switch	on water cock

Pos.	Nomenclature	Remark
S3	Switch, external trigger circulation pump	required, if S2 not installed
S4	Switch	power save operation
U1	Igniter box	
U2	Igniter electrodes	
W1	Wiring harness (1)	
W2	Wiring harness (2)	
A	Plug connections, 6-pole	
C	Plug connections, 1-pole	
D	Plug connections, 4-pole	
F	Plug connections, 2-pole	
X1	Plug connections, 10-pole	
X2	Plug connections, 2-pole	
X3	Plug connections, 8-pole	
X4	Plug connections, 4-pole	
X5	Plug connections, 4-pole	
Y1	Solenoid valve	
Y2	Shut-off valve with filter	

Fig. 709 System Circuit SETRA, Ident.-Nr. 90972

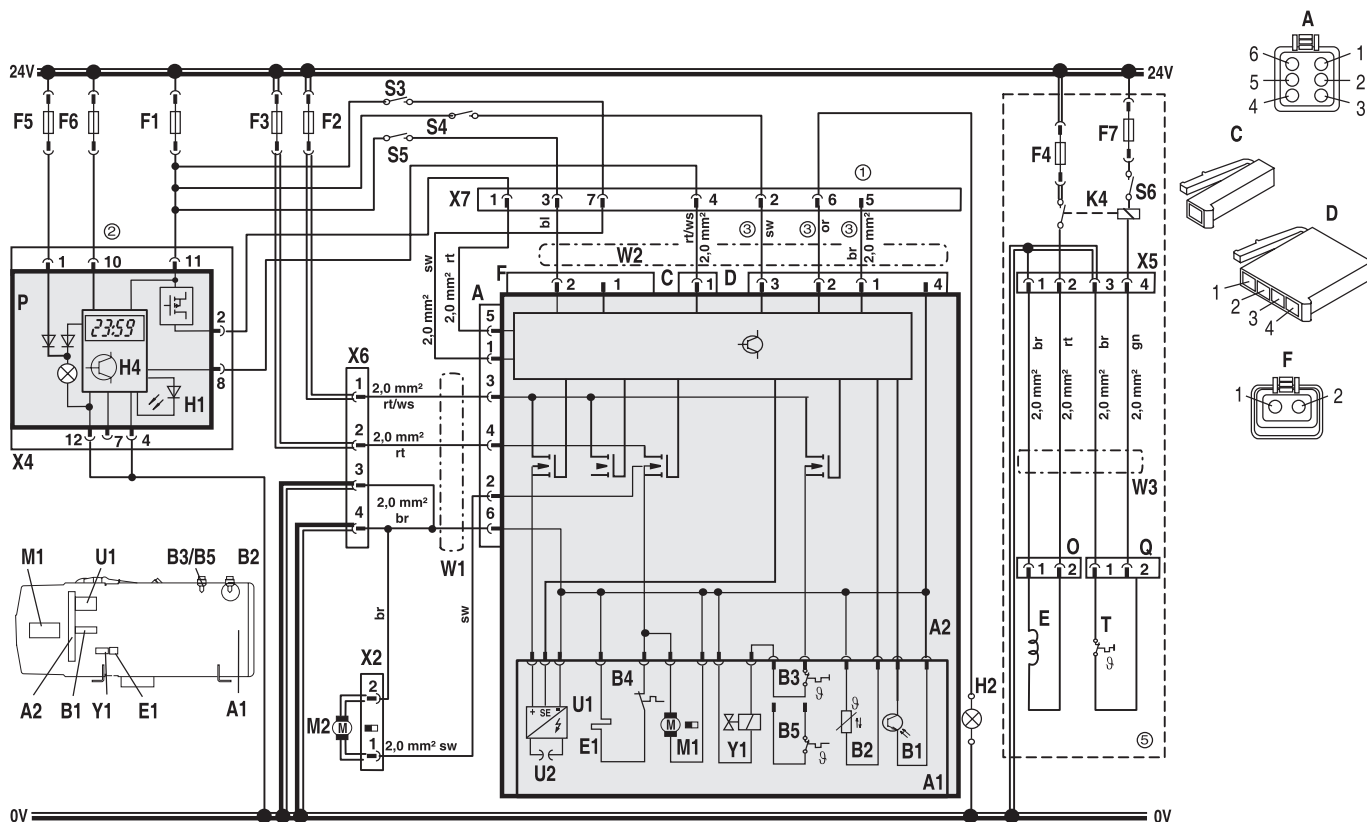

- ① Diagnostic connector
- ③ Timer P:
with plus to connection 4 = continuous operation during immediate heating
without plus to connection 4 = heating period 1 hour
- ③ Pin assignment:

Pin assignment	4wire lead	7wire lead
D1	0.75 gr	0.75 rt
D2	0.75 or	0.75 or
D3	0.75 gn	0.75 bl
D4	0.75 br	2.0 br
F1	not used	2.0 sw
F2	not used	2.0 rt/ws
- ⑤ Option

Wire gauges	
	< 7.5 m
—	7.5 - 15 m
—	0.75 mm ²
—	1.0 mm ²
—	1.5 mm ²
—	2.5 mm ²
—	4.0 mm ²

Wire colors	
bl	blue
br	brown
ge	yellow
gn	green
gr	gray
or	orange
rt	red
sw	black
vi	violet
ws	white

Item	Nomenclature	Remark
A1	Heater	
A2	Control unit	SG 1572D
B1	Flame sensor	observe polarity
B2	Temperature sensor	polarity optional
B3	Temperature limiter	
B4	Thermostat	for nozzle preheating
B5	Thermostat	alternative to B3
B6	Thermostat	for vertical installation (MV Y1)
E	Filter heater	
E1	Heating cartridge	for nozzle preheating
F1	Fuse 25 A	flat fuse DIN 72581 part 3
F2	Fuse 25 A	flat fuse DIN 72581 part 3
F3	Fuse 5 A	flat fuse DIN 72581 part 3
F4	Fuse 25 A	flat fuse DIN 72581 part 3
F5	Fuse 5 A	flat fuse DIN 72581 part 3
F6	Fuse 5 A	flat fuse DIN 72581 part 3
F7	Fuse 5 A	flat fuse DIN 72581 part 3
H1	Light	operation indicator light
H2	Light	flame indicator
H4	Heating symbol on the display	Power-on indicator (in item P)
K4	Relay	
M1	Motor	combustion air fan
M2	Motor	circulation pump

Item	Nomenclature	Remark
P	Digital timer, standard (1531)	For programmed operation
S1	Switch	on / off
S3	Switch	external trigger circulation pump
S4	Switch	power save operation
S5	Switch	Auxiliary heating mode
S6	Switch	Filter heater on
T	Temperature switch	Filter heater
U1	Igniter box	
U2	Igniter electrodes	
W1	Wiring harness (1)	
W2	Wiring harness (2)	
W3	Wiring harness (3)	
A	Plug connections, 6-pole	
C	Plug connections, 1-pole	
D	Plug connections, 4-pole	
F	Plug connections, 2-pole	
O	Plug connections, 2-pole	
Q	Plug connections, 2-pole	
X2	Plug connections, 2-pole	
X4	Plug connections, 12-pole	
X5	Plug connections, 4-pole	
X6	Plug connections, 4-pole	
X7	Plug connections, 7-pole	
Y1	Solenoid valve	

Fig. 710 Automatic Control Circuit Rail with Control Unit 1572D and Standard Timer and filter heater

8 Servicing

8.1 General

This section describes the servicing procedures allowed on the heater when installed.

8.2 Heater Servicing

As long as the heater is in operation or in run-down the battery main power supply must not be disconnected to prevent the heater from overheating by response of the overheat protection.

When performing long time repairs on the heater its removal is appropriate.

After working on the heating circuit replenish with a coolant mix prepared with water and anti-freeze and bleed circuit afterwards according to manufacturer's instructions.

8.3 Vehicle Servicing

CAUTION

In the vicinity of the heater a temperature of 110 °C must under no circumstances be exceeded (e.g. during paint work on the vehicle).

8.4 Heater Test Run

The heater must not be operated, not even with the timer, in enclosed areas like garages or workshops not equipped with exhaust ventilation facilities.

8.5 Maintenance

To ensure functional reliability of the heater the following maintenance must be performed:

- check combustion air inlet and exhaust outlet for contamination and clean as required.
- outside the heating season the heater should be operated with the vehicle engine cold approximately every four weeks for 10 minutes setting the heating system to "warm". This avoids difficulties in the start-up.
- at least once a year, in case of contaminated fuel more often, the fuel filter or filter cartridge as well as the filter screen of the fuel pump must be replaced to avoid malfunctions.
- at least once a year the heat exchanger must be cleaned inside.

- in case of leakage the fuel pump and the fuel lines must be replaced immediately, otherwise every 5 years.
- the heater should be checked in regular intervals by a Webasto service agent, the latest before the beginning of the heating season (refer to Annex A "Scheduled Maintenance").
When the heater is operated in rail vehicles, maintenance chart / test certificate item no. 90 087 22B is to be used.

8.5.1 Inspection and Attachment of the Exhaust Muffler (only heaters from year of production 1996 and up to production date 1996, calendar week 36; 3G.....)

NOTE

If the exhaust muffler is already secured with a sheet metal screw, the following procedure need not be performed.

General

The exhaust muffler of heaters manufactured from the beginning of 1996 up to a manufacturing date of 1998 (calendar week 36; 3G.....) (for year or date of production refer to identification label) the exhaust muffler may get loose or lost under certain circumstances. Therefore an inspection for proper attachment of the muffler should be performed.

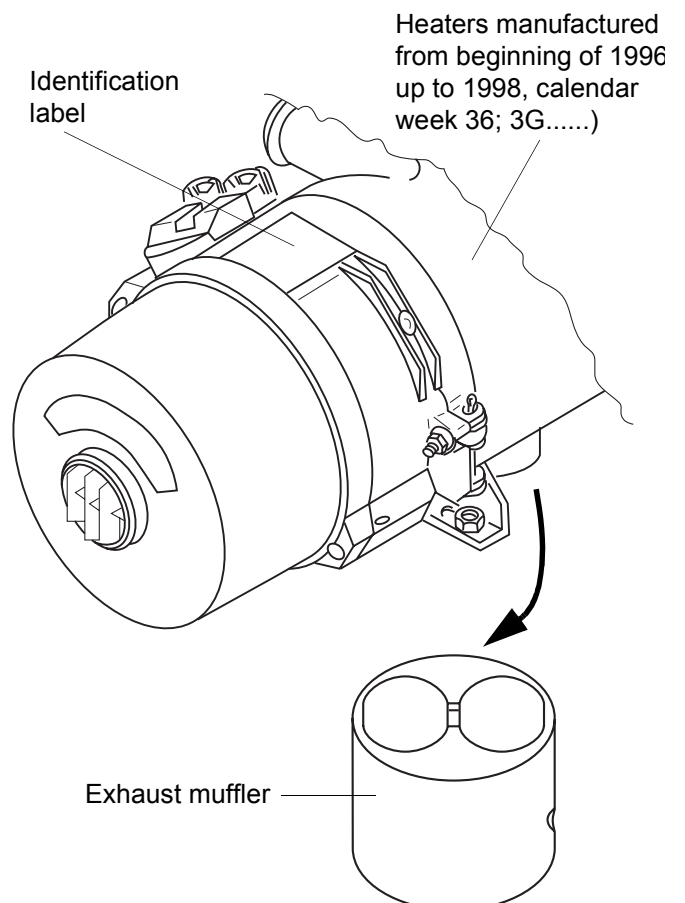

Inspection and Attachment

NOTE

The exhaust muffler must always be secured with a sheet metal screw. Drill a hole with a diameter of 2.5 mm into the exhaust end pipe and muffler and arrest muffler with a sheet metal screw B 3.9 x 25 (see figure).

1. Check exhaust end pipe for presence of muffler. For checking remove exhaust end pipe as required.
2. If muffler is found in exhaust end pipe fasten as described in NOTE. Slot or drill exhaust end pipe and refit.

3. If no muffler is found in exhaust end pipe check if muffler is upstream in exhaust pipe. If muffler is dislocated in the exhaust pipe, arrest muffler as described in NOTE. Slot or drill exhaust pipe and refit.
4. If the exhaust muffler has been lost it may be ordered free of charge from Webasto (ident. no. 206 91C). Fasten muffler according to NOTE. Slot or drill exhaust pipe and refit.
5. If heater is operated without exhaust pipe, fasten muffler according to NOTE. An exhaust deflector (ident. no. 849 70A) must be additionally fitted.

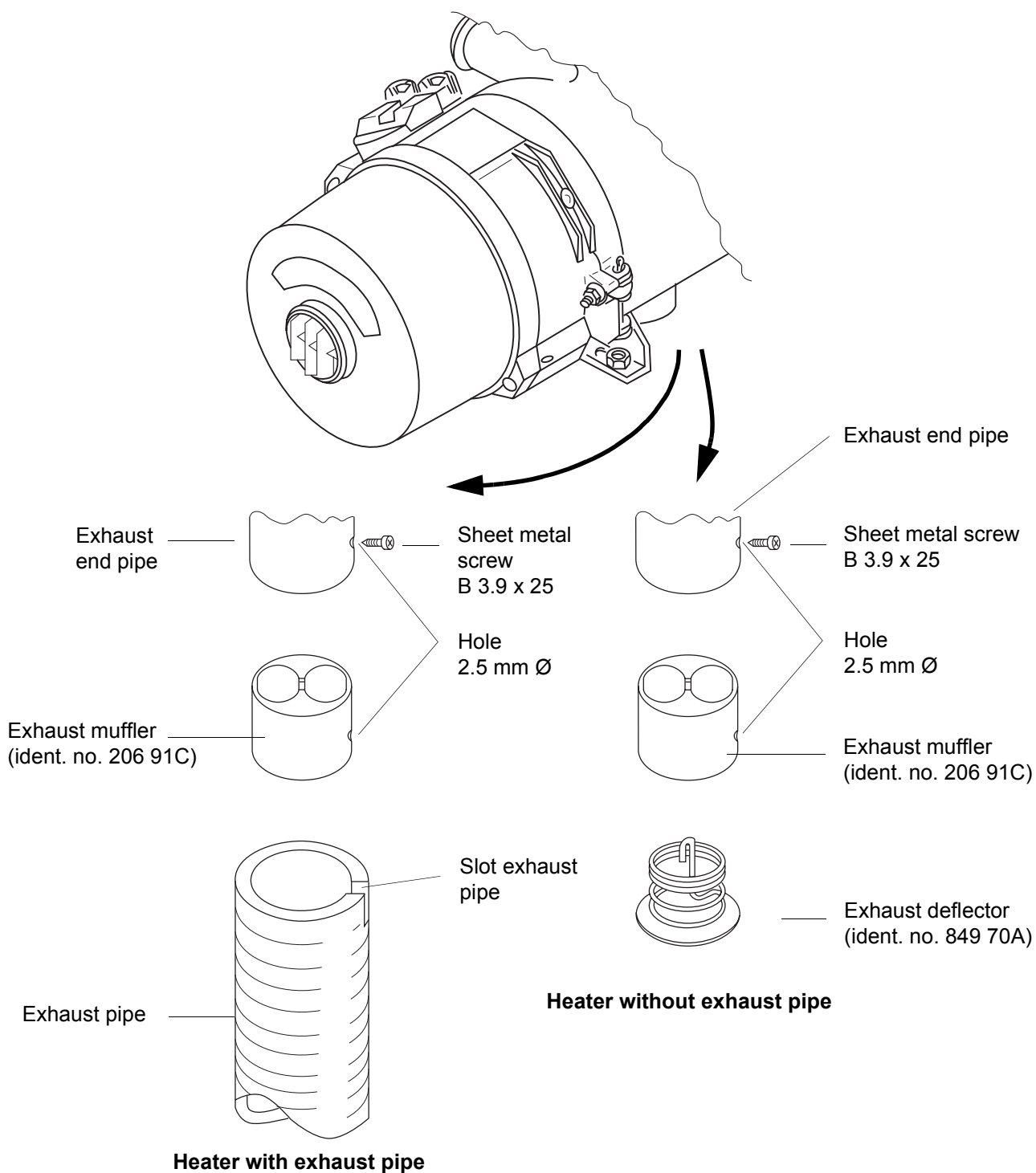

8.5.2 Burner Head Opening and Closing or Removal and Installation

WARNING

The igniter box operates with high voltage. Prior to opening the burner head the connectors of the cable harness in the vehicle have to be disconnected to prevent lethal injuries.

After closing and fixing burner head, reconnect connectors in the vehicle.

NOTE

Maintenance on the heater is easy. By swinging the burner head open the following components become accessible:

- fuel pump and fuel nozzle
- solenoid valve
- igniter box
- igniter electrodes
- flame sensor
- combustion chamber
- nozzle block preheater (if installed)

In order to obtain a convenient burner head opening angle it is required to disconnect the electrical connection(s) to the temperature limiter and temperature sensor.

Opening or removal

1. Disconnect electrical connections to temperature limiter and temperature sensor.
2. Loosen nuts (3, Fig. 801) enough to release hinge bolts (2).
3. Swing hinge bolts (2) out.
4. Swing burner head (4) open.
5. Remove cotter pin (1) as required to remove burner head.

Closing or installation

1. As required fasten burner head (4, Fig. 801) in position using cotter pin (1).
2. Swing burner head (4) closed and locate for assembly.
3. Swing hinge bolts (2) into lock position and secure with nuts (3).
4. Torque nuts (3) with 7.5 Nm + 1 Nm.
5. Reconnect electrical connections to the temperature limiter and temperature sensor.

NOTE

When making electrical connections observe wiring color codes.

- 1 Cotter pin
- 2 Screw (2)
- 3 Nut (2)
- 4 Burner head

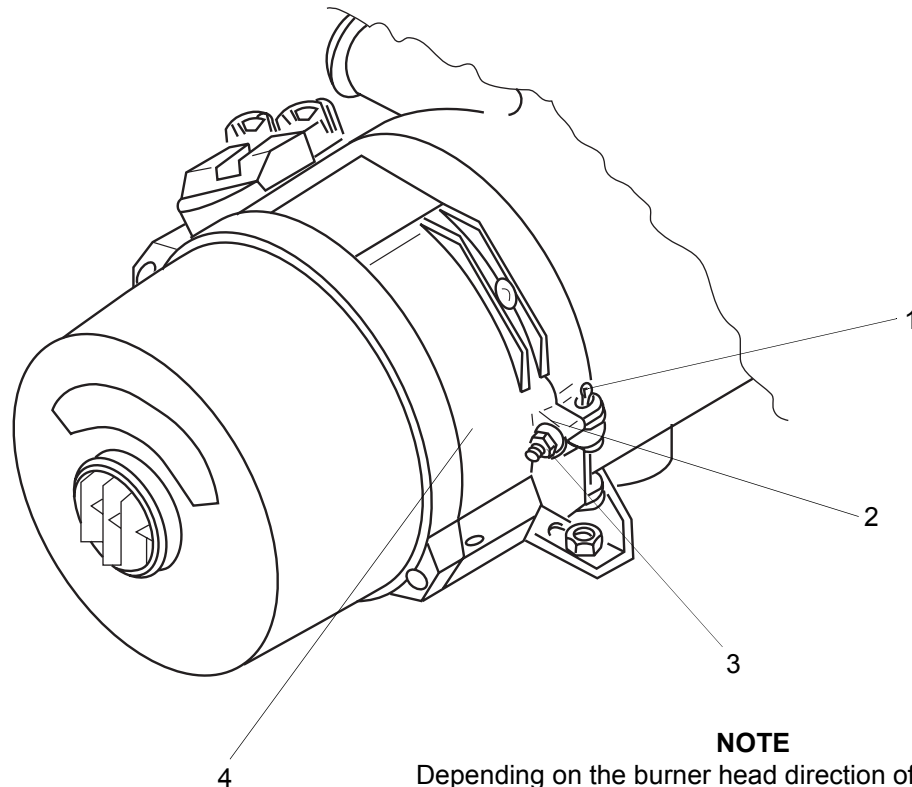

NOTE

Depending on the burner head direction of swing the cotter pin may be located on the opposite side.

Fig. 801 Swinging Burner Head open

8.6 Visual Inspections and Regulations for Installation

8.6.1 Connection to Vehicle Cooling System

The installation of the heater should be in a location as low as possible to ensure self-venting of the heater and circulation pump. This applies in particular for the circulation pump because it is not self-sucking.

The heater is to be connected to the vehicle cooling system according to Fig. 802. The cooling system coolant capacity must be at least 10 liters.

The vehicle cooling system or the separate heating circuit must use only pressure relief valves with an opening pressure of at least 0.4 bar and of max. 2.0 bar.

It is a basic requirement to use the coolant hoses supplied by Webasto, otherwise the hoses must at least meet the specifications of DIN 73411. The hoses have to be installed free of kinks and for proper venting in an inclination. Hose connections must be secured against slippage with hose clamps.

NOTE

The specified tightening torques of the hose clamps used must be complied with.

Prior to the heater's first operation or after replacement of the coolant, attention must be paid to carefully bleed the cooling system. Heater and lines must be installed so that static venting is guaranteed.

Improper venting may cause malfunctions by overheating in equipment operation.

Proper venting may be identified by a circulation pump almost noiseless in operation.

When using a circulation pump U 4851 or Aquavent 6000 S the circulation pump automatically switches off approx. 15 seconds after switch-on should coolant be missing or the pump wheel be seized. After 2 minutes the pump may be reactivated.

In combination with control unit 1572D (Thermo label colored) and with programmed circulation pump check the heater also switches off when coolant is missing.

8.6.2 Connection to Vehicle Fuel System

Fuel is tapped from the fuel reservoir of the vehicle or from a separate fuel tank.

8.6.2.1 Fuel Lines

In order to avoid air from being captured in fuel lines, they should only be installed with an incline. The fuel line joints are to be secured against slipping with hose clamps should no screwed mechanical unions be in use.

Should fuel hoses be installed always use the hoses supplied or offered by Webasto. If other hoses are used they must at least meet the specifications of DIN73379-1C; type 3. Fuel hoses must not be kinked or twisted and must be secured with clamps every 25 cm.

For routing fuel also fuel lines may be used consisting of materials standard in the manufacturing of vehicles, e.g. steel or plastic lines made of unhardened, light and temperature stabilized PA11 or PA12 (e.g. Mecanyl RWTL) according to DIN 73378 observing the applicable jointing instructions.

Basic rules for the routing of fuel lines are:

- Protect against undue temperatures.

WARNING

In overheat condition the heater outer shell may reach Diesel fuel inflammation temperature!

- Protect lines from stone strike.
- **Dripping or evaporating fuel may neither accumulate nor ignite on hot components or electrical equipment.**

Water heating circuit –
Sidewall radiators and roof duct heating

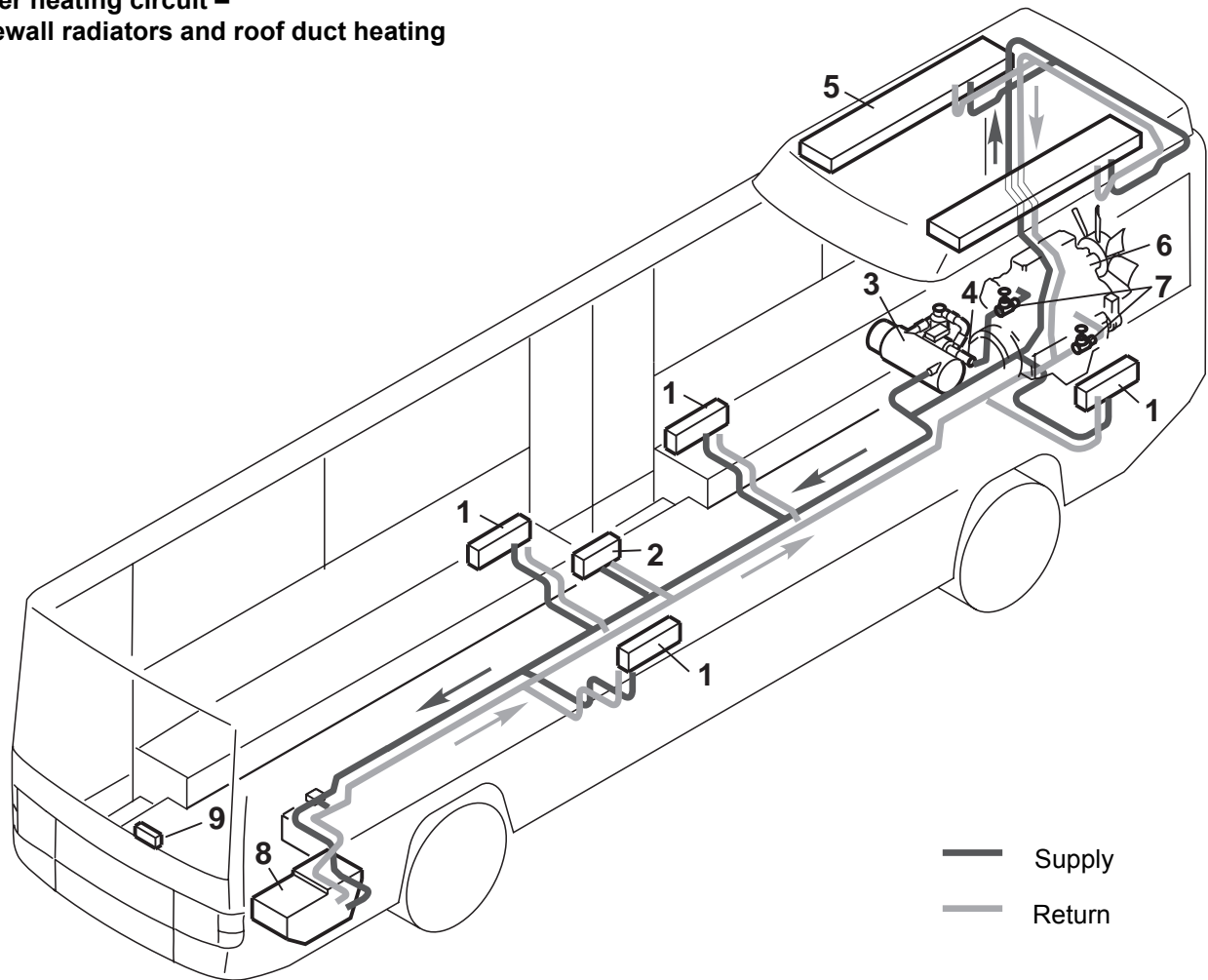

- 1 Sidewall radiator with fan
- 2 Heat exchanger, entrance
- 3 Heater unit
- 4 Circulation pump
- 5 Heat exchanger, roof
- 6 Vehicle engine
- 7 Cockpit heating
- 8 Control element

Fig. 802 Example of a Heater Installation in a Passenger Bus

When installing a shut-off device in the return line a clearly visible information label must be provided.

CAUTION

Operation with the return line shut off causes damage to the fuel pump. Fuel may escape. Danger of fire.

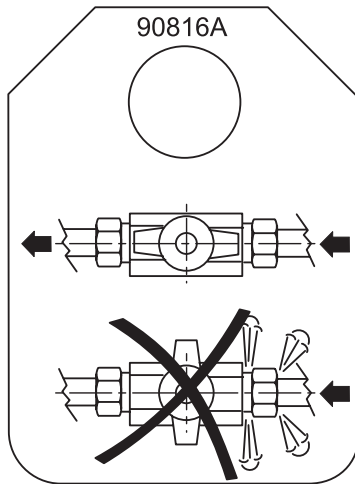

Information label

Loose fuel lines must be secured in order to avoid sagging.

The installation of an additional fuel pump is not allowed.

Fuel lines permissible dimensions:

- inner diameter for suction and return line: 6 mm (other diameters upon request).
- max. permissible length for each suction and return line: 10 m
- Max. permissible suction height: 2 m
- Max. permissible priming pressure: 0.3 bar for suction and return line.

8.6.2.2 Fuel Filter

A fuel filter supplied as deliverable item or cleared for use by Webasto is to be fitted.

Installation position possibly vertical with horizontal direction of flow. To avoid operating malfunctions replace filter or filter cartridge once a year or more often if fuel is contaminated.

8.6.3 Combustion Air Supply

CAUTION

Observe official regulations concerning the installation (see 1.6).

Combustion air must under no circumstances be extracted from rooms with persons. The combustion air inlet must not point towards the forward direction of motion.

It must be located so that no clogging by contamination, impact of snow, or intake of splash water is to be expected.

The combustion air intake and exhaust outlet is to be located so that no air pressure difference builds up in any operating condition of the vehicle.

Permissible dimensions of combustion air intake line:

- inner diameter: 55 mm
- max. length: 5 m without the exhaust extension
- max. bend: 270°

The combustion air inlet must be located so that no exhaust fumes can enter.

NOTE

If the combustion air intake line cannot be routed upwards to the heater, a water drain hole \varnothing 4 mm is to be provided at the lowest point.

If the heater is located near the fuel tank in a common installation compartment, combustion air must be taken in from and the exhaust routed to the exterior. The feedthroughs must be sealed against splash water.

If the heater is located in a closed installation box, a vent port is required:

<i>Thermo 230, 231, 300 and 301</i>	30 cm ²
<i>Thermo 350</i>	35 cm ²

If the temperature in the installation box exceeds the permitted ambient temperature of the heater (see Technical Data), the vent port must be enlarged consulting Webasto.

8.6.4 Exhaust Line

CAUTION

Observe official regulations concerning the installation (see 1.6).

The exhaust pipe outlet opening must not point in the direction of motion.

The exhaust pipe outlet opening must be located so as not to expect clogging by snow or mud.

The combustion air intake and exhaust outlet is to be located so that no air pressure difference builds up in any operating condition of the vehicle.

Rigid pipes made of unalloyed or alloyed steel with a minimum wall thickness of 1.0 mm have to be used as exhaust line or flexible pipes made of alloyed steel only. The exhaust pipe is secured to the air heater e.g. with a clamp.

Permissible exhaust line dimensions:

- inner diameter: 70 mm
- max. length: 5 m without the exhaust extension
- max. bend: 270°

As an alternative an exhaust deflector must be installed cleared by Webasto.

8.7 Removal and Installation

CAUTION

In installed condition only the following disassembly or removal procedures are permitted should enough space for removal allow such action:

- replacement of temperature limiter
- replacement of temperature sensor
- replacement of combustion air fan
- replacement of burner
- replacement of igniter box
- replacement of flame sensor
- replacement of combustion chamber

8.7.1 Heater, Removal and Installation

8.7.1.1 Removal

1. Disconnect connectors of cable harness in vehicle and of circulation pump.
2. Disconnect combustion air intake on heater if required.
3. Loosen clamp on exhaust outlet.
4. Loosen fuel supply and return line connections and fit dummy plugs.
Close water cocks as applicable.
5. Loosen hose clamps on coolant hoses, disconnect hoses and fit dummy plugs.
6. Remove 3 screws and washers or 4 screws and washers.
7. Remove heater.

8.7.1.2 Installation

1. Locate heater for installation and secure with 3 screws and washers or 4 screws and washers.
2. Secure line on exhaust outlet using clamp.
3. Slide on coolant hoses and fasten with hose clamps.
Torque clamps with 1.5 Nm. Open water cocks.
4. Connect fuel supply and return lines and tighten connections or screw tight with banjo bolt and new gaskets.

5. Secure combustion air inlet line on heater as applicable.
6. Connect electrical connectors of cable harness in vehicle and to circulation pump.
7. Bleed fuel supply system.
8. Bleed coolant circuit.

8.7.2 Temperature Limiter, Replacement

NOTE

The replacement procedure for the temperature limiter is identical with the heater installed or removed. Perform replacement in accordance with 9.2.1.

8.7.3 Temperature Sensor, Replacement

NOTE

The replacement procedure for the temperature sensor is identical with the heater installed or removed. Perform replacement in accordance with 9.2.2.

WARNING

Prior to replacement of temperature sensor in installed condition relief overpressure in cooling system by opening the cooling circuit sealing element. If required also allow heater to cool down and have collector vessel ready to collect escaping coolant.

8.7.4 Burner, Replacement

NOTE

The replacement procedure for the burner is identical with the heater installed or removed. Perform replacement in accordance with 9.2.3.

WARNING

The igniter box operates on high voltage. Prior to replacement of burner disconnect electrical connectors of cable harness in vehicle to avoid lethal accidents.

8.7.5 Igniter Box, Replacement

NOTE

The replacement procedure for the igniter box is identical with the heater installed or removed. Perform replacement in accordance with 9.2.7.

WARNING

The igniter box operates on high voltage. Prior to replacement of igniter box disconnect electrical connectors of cable harness in vehicle to avoid lethal accidents.

8.7.6 Flame Sensor, Replacement**NOTE**

The replacement procedure for the flame sensor is identical with the heater installed or removed. Perform replacement in accordance with 9.2.8.

WARNING

The igniter box operates on high voltage. Prior to replacement of flame sensor disconnect electrical connectors of cable harness in vehicle to avoid lethal accidents.

8.7.7 Combustion Chamber, Replacement**NOTE**

The replacement procedure for the combustion chamber is identical with the heater installed or removed. Perform replacement in accordance with 9.2.10.

WARNING

The heater operates on high voltage. Prior to replacement of combustion chamber disconnect electrical connectors of cable harness in vehicle to avoid lethal accidents.

8.8 First Operation

After heater installation the coolant circuit and the fuel supply system must be thoroughly bled observing the vehicle manufacturer's instructions. During test runs all coolant and fuel line connections have to be checked for security and no leakage. Should the heater in operation enter a fault condition, perform troubleshooting (refer to Section 5).

NOTE

Heaters with control unit 1572D:
If the heater performs 8 subsequent attempts to start due to a malfunction, the heater enters an error lockout and stops any further attempts to start. This error lockout is superior to the normal error lockout condition. The error lockout reset is achieved by switching the heater on and disconnection of the heater power supply within 120 sec. during run-down.

8.8.1 Water Circuit, Bleeding**NOTE**

Bleeding must always be performed in accordance with manufacturer's instructions. For bleeding the circulation pump must not be switched on.

Set vehicle own heating system to "warm" and replenish coolant which must consist of at least 20 % anti-freeze (on glycol base) (protection against corrosion). When using pure water there will be no protection against corrosion and due to the lower boiling point of the water when overheating loss of cooling water may result requiring continuous replenishment. Additives in the coolant must not affect metals, plastics or rubber and leave no deposits.

Then operate engine at increased idle until radiator thermostat opens. Shut down engine, check coolant level and replenish as required.

Switch on heater and vehicle heating fan with engine shut down. After a certain cool-down period the heater must automatically switch on and control to off. In case of no restart attempt the temperature limiter on the heater has responded because the heater has not been bled properly. Reset temperature limiter (push button on temperature limiter) and repeat complete bleeding procedure.

NOTE

The heater may be equipped with an automatically resetting temperature limiter. The manual reset is not necessary.

8.8.2 Fuel Supply System, Bleeding

When switching the heater on the fuel pump sucks fuel to prime the complete fuel supply system.

Should no combustion be achieved with the first start attempt, switch the heater off and on again.

9 Repair

9.1 General

This section describes the repairs that may be performed on the heaters *Thermo 230, 231, 300, 301* and *350* when removed. Any further disassembly will void the warranty. For re-assembly only components of the proper spare part kits are to be used.

WARNING

The igniter box operates on high voltage. The following components may also be replaced with the heater installed unless restricted space prevents access:

- temperature limiter
- temperature sensor
- combustion air fan
- burner
- igniter box
- flame sensor
- combustion chamber

Prior to replacement disconnect connectors of cable harness in vehicle to avoid lethal accidents.

WARNING

Hot coolant may escape during the replacement of the temperature sensor.

Before replacing the temperature sensor also release pressure from cooling system by opening sealing element.

If required also allow heater to cool down.

9.1.1 Work on Components after Disassembly**CAUTION**

All gaskets located between disassembled components must always be replaced and discarded.

9.1.1.1 Visual Inspection, General

- Examine all components for damages (cracks, deformation, wear, etc.) and replace as necessary.
- Examine connectors and wiring for corrosion, loose contacts, wrong crimping, etc. and repair as necessary.
- Check terminals for corrosion and contacts for security. Repair as required.

9.1.1.2 Combustion Chamber, Visual Inspection

- Check swirl ring for security.
- Inspect combustion chamber for oxidizing and coke deposits and remove as required.
- Check welding seem for cracks.

NOTE

Longitudinal cracks up to 80 mm are allowed.

9.1.1.3 Heat Exchanger, Visual Inspection

- Inspect exhaust ducting in heat exchanger for sooting, deposits, damage and corrosion.

NOTE

Deposits are to be removed with water jet and brush.

- Inspect heat exchanger for exterior damage, deformation, etc.

NOTE

Heavy deformation may cause restricted flow of coolant.

CAUTION

When replacing the combustion chamber on heaters installed vertically, remove deposits in heat exchanger using a suitable tool.

9.1.1.4 Combustion Air Fan Wheel, Visual Inspection

- Check fan wheel for contamination and cracks.
- Check cover plate for security.
- Check slide lock for proper seating.

9.1.2 Incorporation of Modifications**NOTE**

Continuous enhancement of heater design is for optimizing performance and avoiding failures and malfunctions. Normally equipment in use may be retrofitted using available modification kits

The following modifications may be incorporated during repair procedures:

- installation of control unit 1572D as substitute for control unit 1572 (see 9.1.2.1)
- installation of circulation pump U 4851 or Aquavent 6000 S as substitute for circulation pump U 4814 or U 4816 (see 9.1.2.2)
- installation of circulation pump Aquavent 5000 S as substitute for circulation pump U 4814

9.1.2.1 Installation of Control Unit 1572D as Substitute for Control Unit 1572

General

Due to the progress in the development of processors control unit 1572 can no longer be supplied. The retrofit of control unit 1572D is performed according to the following procedure:

The modification kit consists of:

- control unit 1572D
- igniter box
- thermo identification label

Procedure

CAUTION

Control unit 1572D may only be used in combination with the igniter box delivered (green connector cover). The electrical connector is coded.

1. Remove control unit according to 9.2.5.1 and discard.
2. Remove igniter box according to 9.2.7.1 and discard.
3. Install new igniter box according to 9.2.7.2.
4. Install new control unit according to 9.2.5.2.
5. Apply new thermo label onto existing label to indicate retrofit.

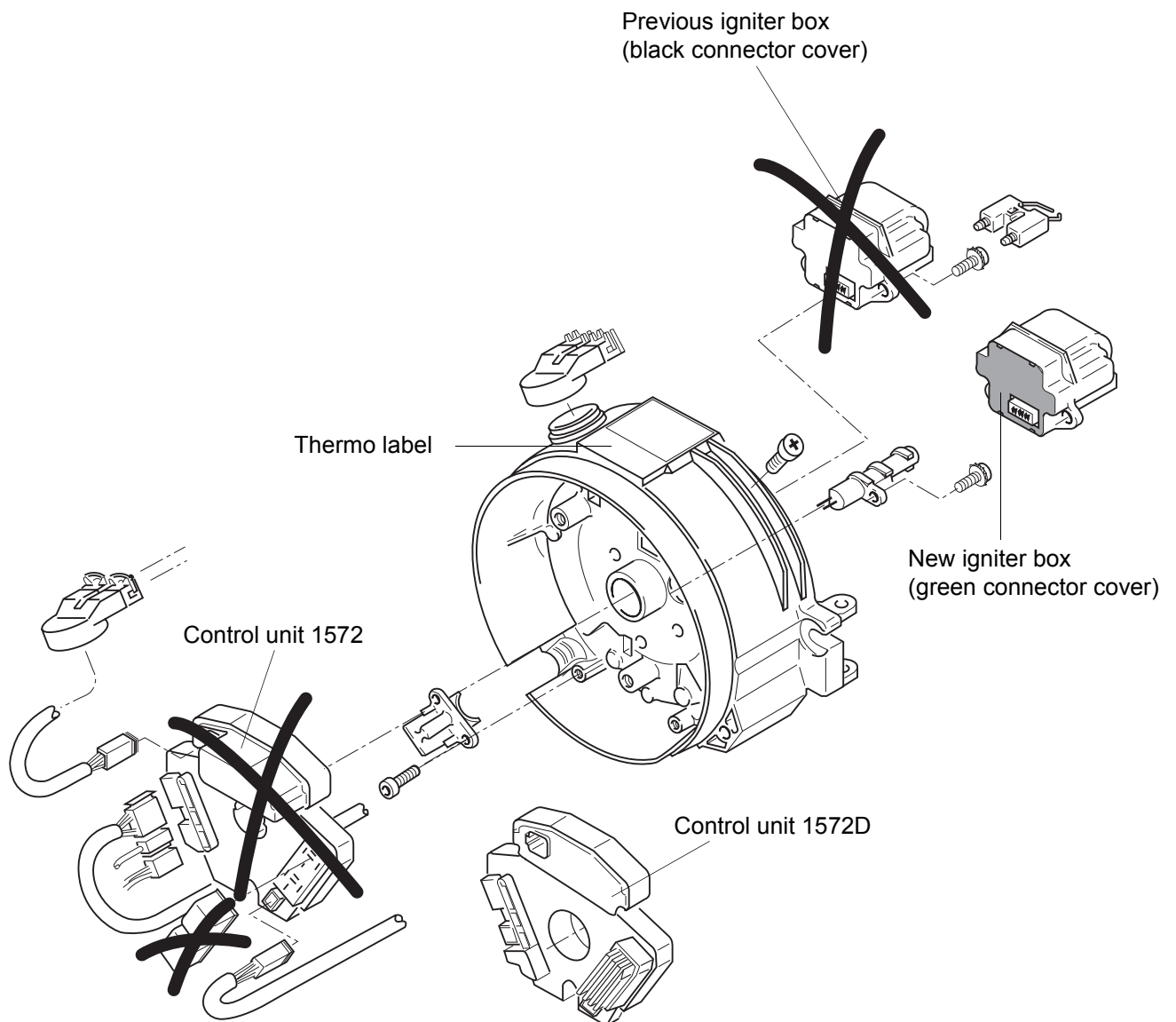

9.1.2.2 Installation of Circulation Pump U 4851 / Aquavent 6000 S or 5000 S as Substitute for Circulation Pump U 4814 or U 4816

General

The circulation pumps U 4814 and U 4816 may be substituted by circulation pump U 4851 or Aquavent 6000 S respectively 5000 S as required.

When exchanging circulation pump U 4816 the attachment parts (mount and hose clamp) may be re-used. An adaptation of the water connection is not necessary. The same applies for compact units.

When exchanging circulation pump U 4814 observe the following:

- The existing mount and hose clamp must be removed and discarded. Installation must be performed using a new mount and hose clamp.
- When mounting the circulation pump near to a wall the new mount must be attached so that there is a clearance of 60 mm to the wall (reference line: circulation pump centerline). If required the new mount must be relocated in relation to the old mount.
- Hose connections must be adapted.
- If the circulation pump is mounted into a compact unit, the exchange procedure is difficult and must be checked if practicable.
- The modification cannot be performed when water stations Starliner and Cityliner and involved.

Procedure, circulation pump U 4851

CAUTION

When installing circulation pump U 4851 the following information must be strictly observed to avoid loss of warranty.

NOTE

- The circulation pump is not self-venting. Therefore the pump has to be installed at the lowest point of the water circuit observing the permitted pump orientation (see Fig.).
- The hoses must be installed routed upwards free of kinks. Hose connections must be secured against slippage with hose clamps. The specified tightening torques of the hose clamps used must be complied with.
- On the water inlet side of the pump no solenoid valves or other shut-off devices must be installed allowing closure during pump operation. The same applies for filters which may clog.
- Prior to first operation of the circulation pump the vehicle cooling system and the pump body must be bled.

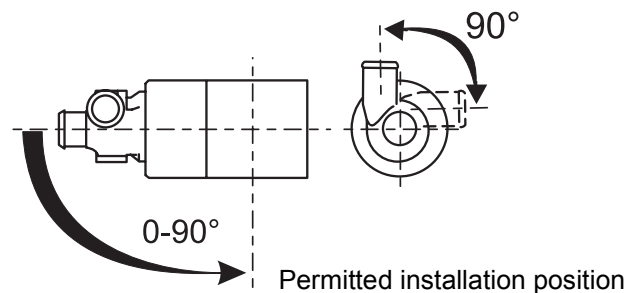

CAUTION

Improper bleeding or a dry run of the pump causes damage to the slip ring gasket. Proper venting is indicated by the pump operating almost noiseless.

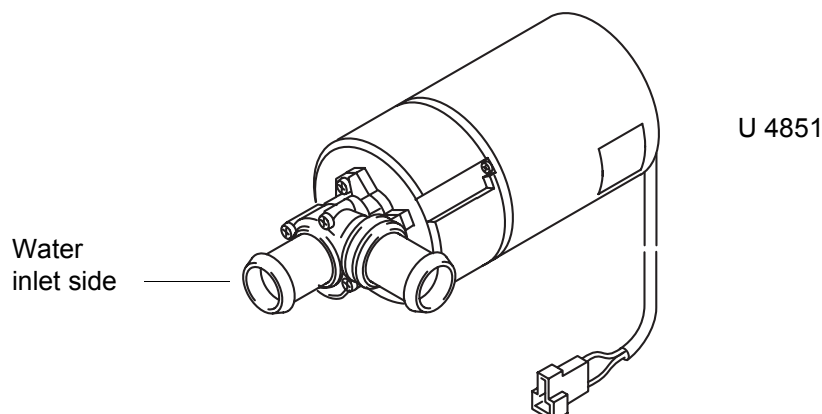

Procedure, circulation pump Aquavent 6000 S

CAUTION

When installing circulation pump Aquavent 6000 S the following information must be strictly observed to avoid loss of warranty.

NOTE

- Different to pump U 8451, Aquavent 6000 S is to be installed in a vertical position, so that the pump head is located above the motor.
- The circulation pump is not self-venting. Therefore the pump has to be installed at the lowest point of the water circuit observing the permitted pump orientation (see Fig.).
- The hoses must be installed routed upwards free of kinks. Hose connections must be secured against slippage with hose clamps. The specified tightening torques of the hose clamps used must be complied with.
- On the water inlet side of the pump no solenoid valves or other shut-off devices must be installed allowing closure during pump operation.

The same applies for filters which may clog.

- Prior to first operation of the circulation pump the vehicle cooling system and the pump body must be bled.
- The circulation pump includes no parts subject to wear. A motor replacement in some cases is also possible without removal of the pump head.

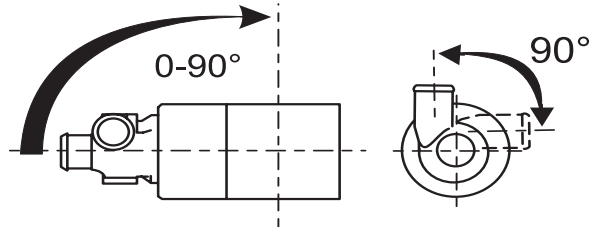

Permitted installation position

CAUTION

A dry run of the circulation pump is permitted up to 15 minutes. Proper bleeding may be verified by almost noiseless operation of the pump.

Aquavent 6000 S

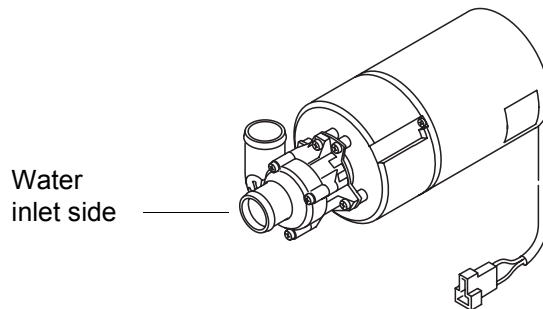

9.2 Disassembly and Assembly**9.2.1 Temperature Limiter, Replacement****9.2.1.1 Removal**

1. Disconnect electrical connection to temperature limiter.
2. Withdraw rubber cap. Using screw driver lever off retaining spring and remove temperature limiter (1, Fig. 901).

9.2.1.2 Installation

1. Slide rubber cap of temperature limiter (1, Fig. 901) back until temperature limiter can be located for installation.
2. Position temperature limiter (1) in connector (3) and push in retaining clip.

WARNING

The retaining spring must be located in the groove of the housing and must be latched in position both perceptibly and audibly (twice) at the collar of the locating socket. Only then will the temperature limiter be in proper contact with the heat exchanger jacket.

3. Fit rubber cap.
After the rubber cap has been placed in position, the cable must be aligned in the cable sleeve, free from strain.
Connection cables must not be routed over reset button.

NOTE

Observe electrical wiring color coding when making connections to temperature limiter.

4. Make electrical connections.

9.2.2 Temperature Sensor, Replacement**9.2.2.1 Removal**

1. Disconnect electrical connection to temperature sensor.

WARNING

Prior to replacement of temperature sensor in installed condition relief overpressure in cooling system by opening the cooling circuit sealing element.
If required also allow heater to cool down and have collector vessel ready to collect escaping coolant.

2. Unscrew temperature sensor (2, Fig. 901) and remove.

9.2.2.2 Installation

1. Manually screw temperature sensor (2, Fig. 901) into coolant outlet (4).
2. Torque temperature sensor to 20 Nm +5 Nm.
3. Restore electrical connections.

NOTE

Observe electrical wiring color coding when making connections to temperature sensor.

9.2.3 Burner, Replacement**9.2.3.1 Removal**

1. Disconnect electrical connections on burner and loosen fuel lines.
2. Loosen nuts (6, Fig. 901) until hinge bolts are free.
3. Swing hinge bolts (7) open and remove cotter pin (5).
4. Remove burner (8).
5. Perform procedures on components after disassembly (refer to 9.1.1).

9.2.3.2 Installation

1. Position burner (8, Fig. 901) for installation, swing hinge bolts closed and secure temporarily using screws (6).
2. Insert cotter pin (5) according to the intended opening swing direction.
3. Tighten nuts (6) with 7.5 Nm + 1 Nm.
4. Connect fuel lines.
5. Restore electrical connections.

NOTE

Observe electrical wiring color coding when making connections to temperature limiter and temperature sensor.

- 1 Temperature limiter
- 2 Temperature sensor
- 3 Connector
- 4 Coolant outlet
- 5 Cotter pin
- 6 Nut (2)
- 7 Hinge bolt (2)
- 8 Burner

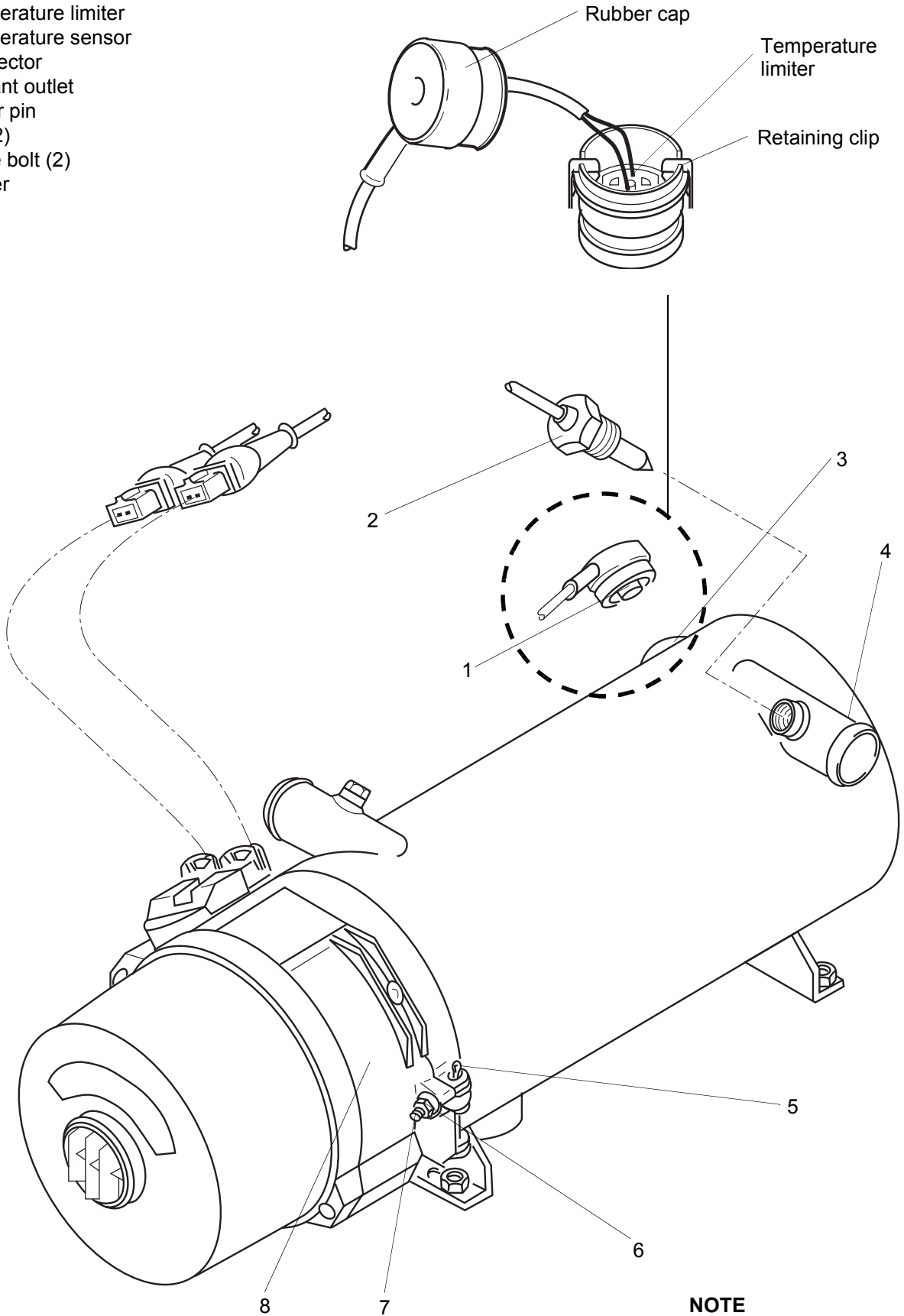

NOTE
Cotter pin (5) may be fitted on other side as required for burner head to swing open in opposite direction.

Fig. 901 Temperature Limiter, Temperature Sensor and Burner, Replacement

9.2.4 Combustion Air Fan, Replacement

NOTE

For replacement of the combustion air fan the burner may be left installed.

In removed condition ensure that igniter electrodes are not bent and nozzle is not damaged.

9.2.4.1 Removal

1. Loosen screws (3, Fig. 902) and withdraw cap (2) from burner.
2. Using suitable tool (e.g. mandrel 3 mm) open slide lock (5) until fan wheel can be pulled off.
3. Disconnect electrical connector (9).
4. Remove screws (6) with lock washers and withdraw fan motor (7).
5. Perform procedures on components after disassembly (refer to 9.1.1).

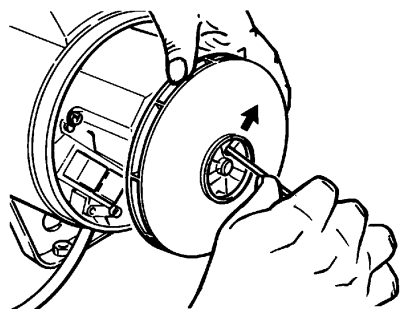

Opening slide lock

9.2.4.2 Installation

NOTE

Fan motor (7, Fig. 902) to be aligned with control unit (recess in mounting flange) and with clutch (by rotating drive shaft).

1. Align fan motor (7) and position for installation.
2. Attach fan motor using screws (6) and lock washers.
3. Tighten screws with 5 Nm + 1 Nm.
4. Connect electrical connector (9).
5. Bring slide lock (5) on fan wheel in installation position.
6. Slide fan wheel onto drive shaft and using suitable tool (e.g. mandrel 3 mm or pliers) close slide lock until fan wheel is locked.
7. Locate cap (2) and secure with screws (3).
8. Tighten screws with 2 Nm.

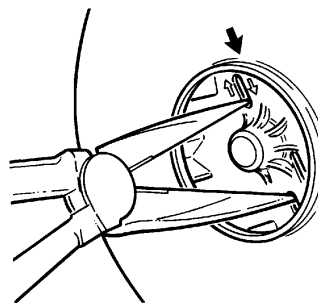

Closing slide lock

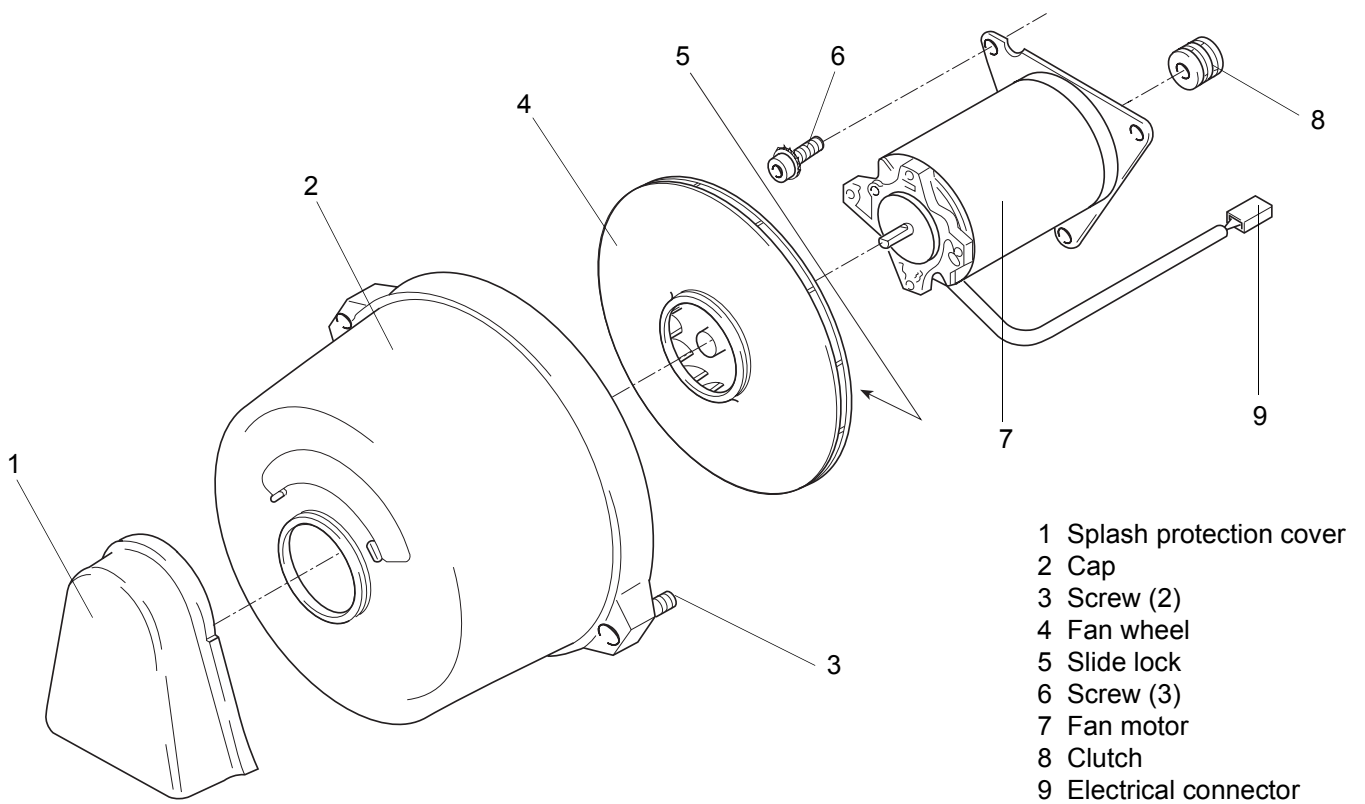

Fig. 902 Combustion Air Fan, Replacement

9.2.5 Control Unit, Replacement

NOTE

For replacement of the control unit the burner head may be left installed and must only be swung open for disconnection of electrical connector (8, Fig. 903). In removed condition ensure that igniter electrodes are not bent and nozzle is not damaged. If a control unit 1572 is substituted with a control unit 1572D, perform procedure according to 9.1.2.1.

9.2.5.1 Removal

1. Disconnect all electrical connections from control unit (23, Fig. 903).
2. Swing burner head open (refer to 8.5.1) and disconnect electrical connector (8).
3. Remove flame sensor (refer to 9.2.8.1).
4. Remove combustion air fan (refer to 9.2.4.1).
5. Carefully withdraw control unit (23) in axial direction from burner head (17) and remove.
6. Perform procedures on components after disassembly (refer to 9.1.1).

9.2.5.2 Installation

1. Carefully push control unit (23, Fig. 903) in axial direction against stop into burner head (17).
2. Install combustion air fan (refer to 9.2.4.2).
3. Make all electrical connections on control unit (23).
4. Install flame sensor (refer to 9.2.8.2).
5. Connect electrical connector (8).

9.2.6 Fuel Pump, Replacement

9.2.6.1 Removal

1. Remove burner (refer to 9.2.3.1).
2. Using screwdriver lever off igniter electrodes (3, Fig. 903) from igniter box (1) and remove.
3. Remove disk (6, Fig. 903) with heating cartridge (if installed).
4. Disconnect electrical connector (8).

NOTE

During the following step ensure that escaping fuel is immediately neutralized and properly disposed of.

5. Remove screws (9) with lock washers.
6. Withdraw fuel pump (10) together with solenoid valve (7) and remove.
7. Remove and discard O-rings (12) and filter screen (11).
8. Remove solenoid valve (7) from fuel pump (10) as required.
9. Perform procedures on components after disassembly (refer to 9.1.1).

9.2.6.2 Installation

1. Install solenoid valve (7, Fig. 903) on fuel pump (10) if required.
2. Fit new O-ring (12) and filter screen (11) on fuel pump (10).
3. Position fuel pump (10) for installation and secure with screws (9) and lock washers.
4. Tighten screws with 5 Nm + 1 Nm.
5. Connect electrical connector (8).
6. Plug on disk (6) and mount heating cartridge.
7. Plug on igniter electrodes (3, Fig. 904).
8. Install burner (refer to 9.2.3.2).

9.2.7 High Pressure Nozzle, Replacement

9.2.7.1 Removal

1. Remove burner (refer to 9.2.3.1).
2. Using screwdriver lever off igniter electrodes (3, Fig. 903) from igniter box (1) and remove.
3. Remove disk (6, Fig. 903) with heating cartridge (if installed).
4. Disconnect electrical connector (8) of the heating cartridge.
5. Unscrew high pressure nozzle (4).

NOTE

Ensure cleanliness is maintained when installing the nozzle. Only touch the nozzle at its hexagon surface.

9.2.7.2 Installation

1. Screw in high pressure nozzle (4, Fig. 903) and tighten with 20 Nm.
2. Connect electrical connector (8) of the heating cartridge.
3. Plug on disk (6) and mount heating cartridge.
4. Plug on igniter electrodes (3, Fig. 903).
5. Install burner (refer to 9.2.3.2).

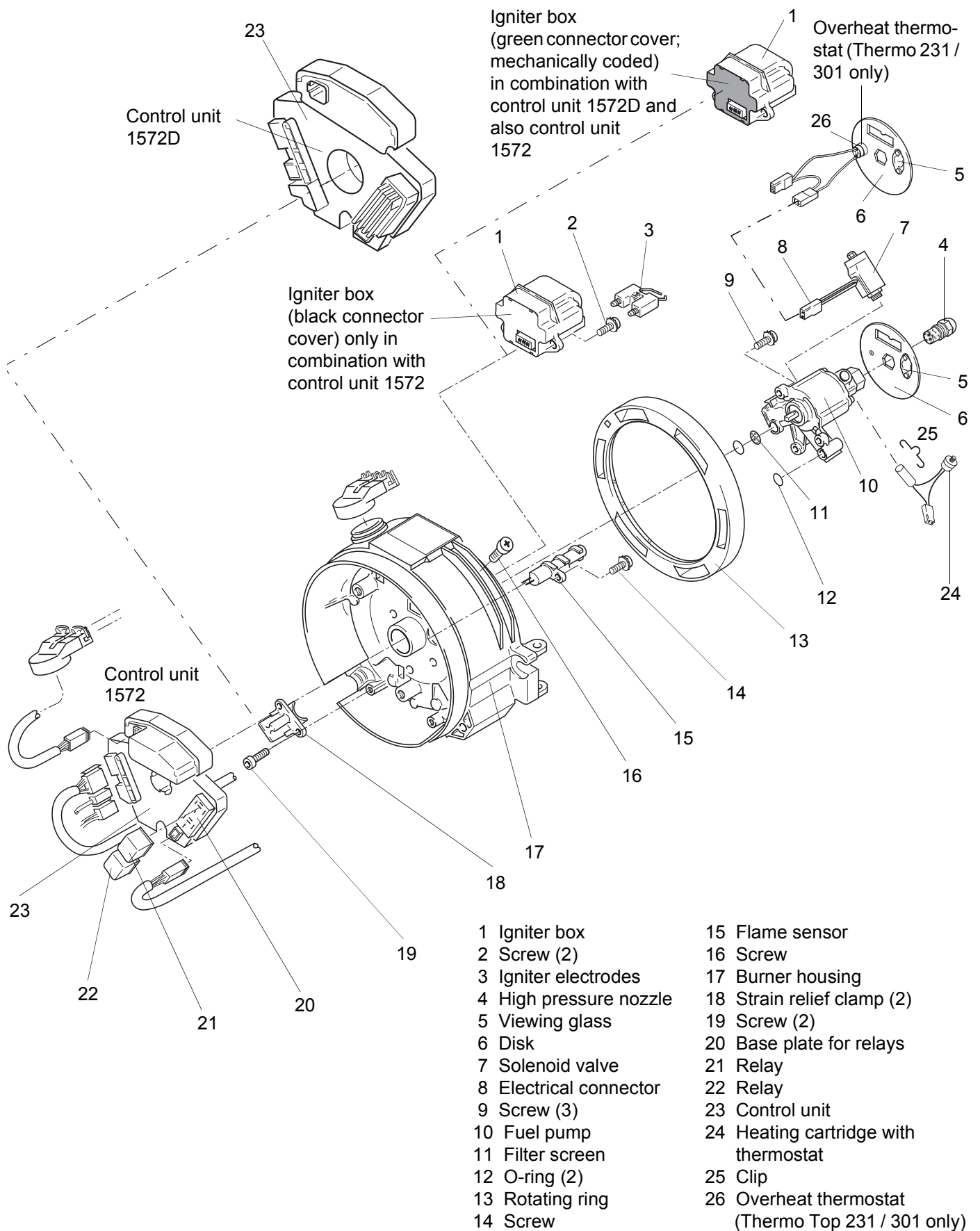

Fig. 903 Control Unit and Fuel Pump, Replacement

9.2.8 Igniter Box, Replacement**9.2.8.1 Removal**

1. Remove burner if required (refer to 9.2.3.1).
2. Using screw driver lever off igniter electrodes (Fig. 904) from igniter box and remove.
3. Remove disk (6).
4. Remove screws (2) with lock washers.
5. Withdraw igniter box (1) and remove.
6. Perform procedures on components after disassembly (refer to 9.1.1).

9.2.8.2 Installation

1. Locate igniter box (1, Fig. 904) for installation, plug on making correct electrical connections and secure with screws (2) and lock washers.
2. Tighten screws (2) with 5 Nm + 1 Nm.
3. Plug on disk (6) and align.
4. Plug on igniter electrodes (3).
5. Install burner (refer to 9.2.3.2).

9.2.9 Flame Sensor, Replacement**9.2.9.1 Removal**

1. Remove burner if required (refer to 9.2.3.1).
2. If required lever off igniter electrodes (Fig. 904) from igniter box using screw driver and remove.
3. Remove disk (6).
4. Remove screw (14) and lock washer.
5. Withdraw flame sensor (15) and remove.
6. Perform procedures on components after disassembly (refer to 9.1.1).

9.2.9.2 Installation

1. Position flame sensor (15, Fig. 904) for installation, plug on to make correct electrical connections and secure with screw (14) and lock washer.
2. Tighten screw (14) with 5 Nm + 1 Nm.
3. Plug on disk (6) and align.
4. Plug on igniter electrodes (3).
5. Install burner (refer to 9.2.3.2).

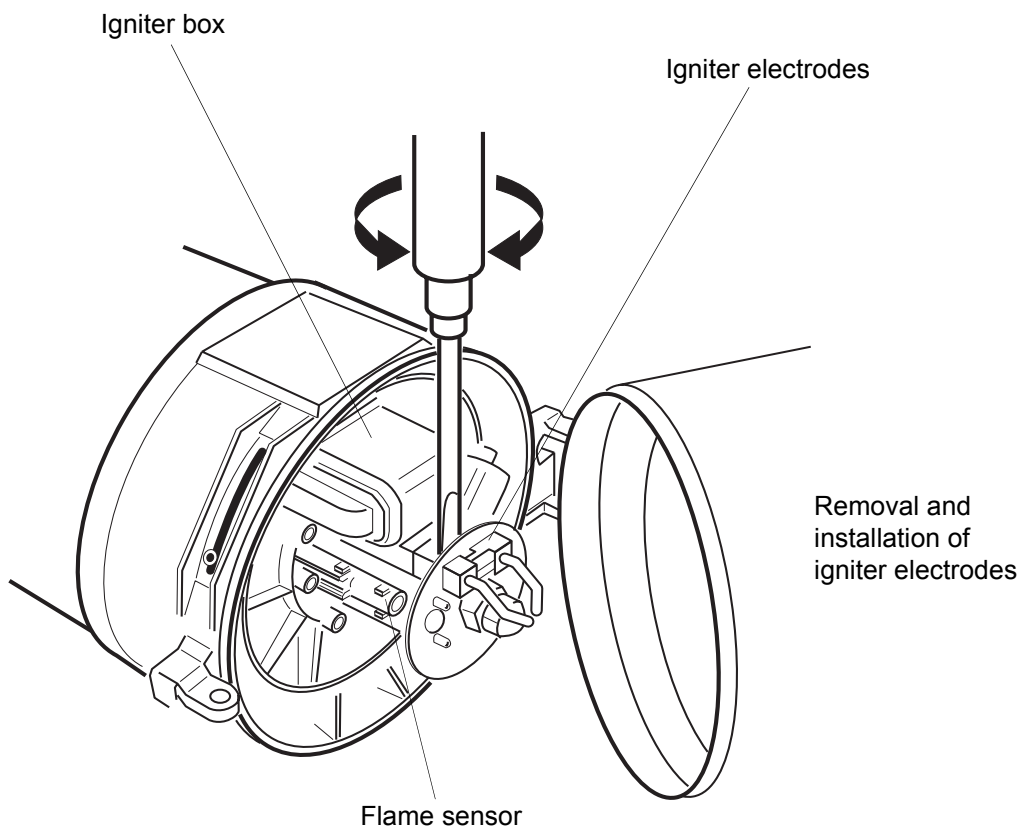

Fig. 904 Igniter Box and Flame Sensor, Replacement (Sheet 1 of 2)

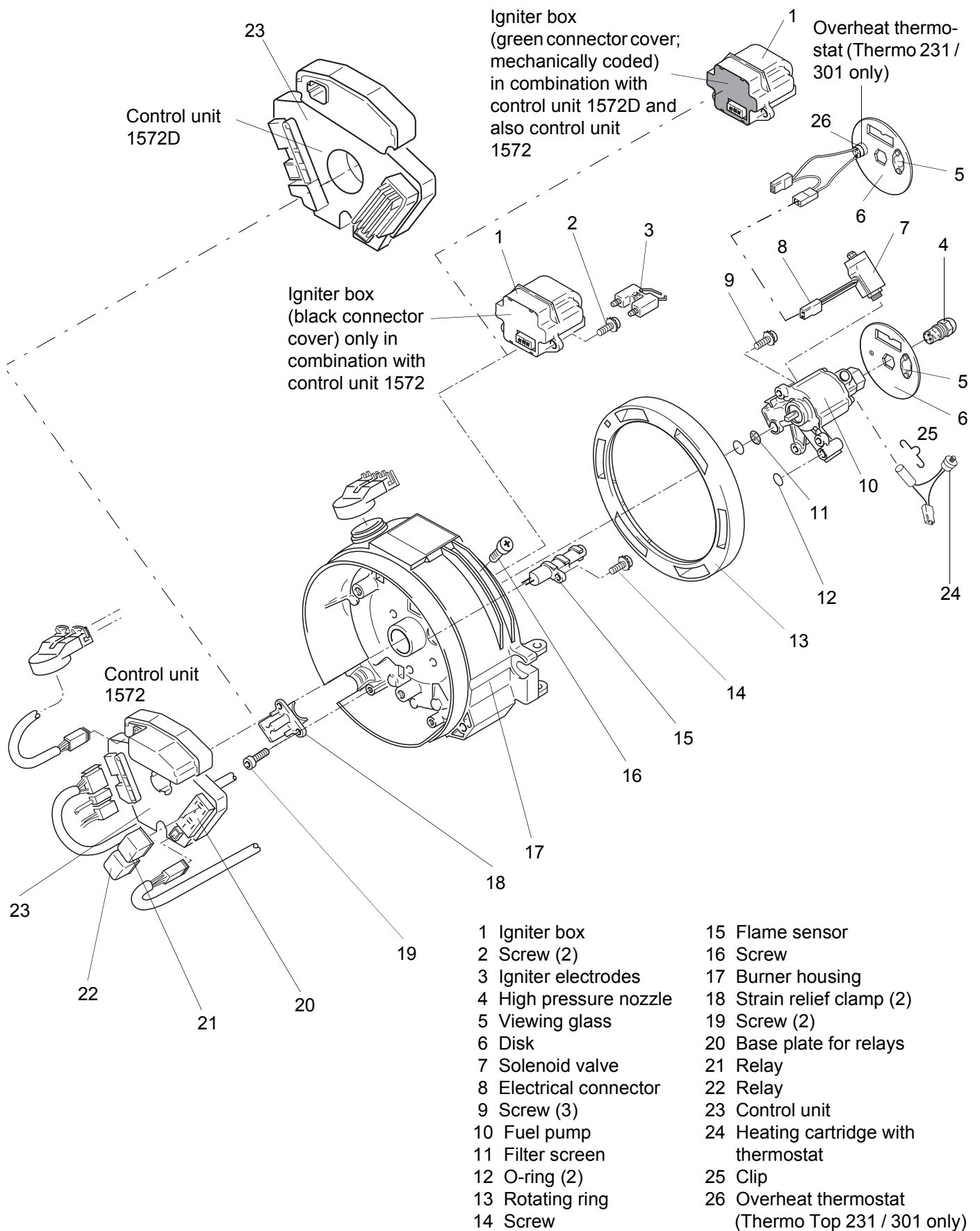

Fig. 904 Igniter Box and Flame Sensor, Replacement (Sheet 2 of 2)

9.2.10 Heat Exchanger, Replacement**9.2.10.1 Removal**

1. Remove temperature limiter (refer to 9.2.1.1).
2. Remove temperature sensor (refer to 9.2.2.1).
3. Remove burner (refer to 9.2.3.1).
4. Withdraw combustion chamber (1, Fig. 905) from heat exchanger (2).
5. Remove heat exchanger (2).
6. Perform procedures on components after disassembly (refer to 9.1.1).

9.2.10.2 Installation

1. Slide combustion chamber (1, Fig. 905) fully into heat exchanger (2) against stop.
2. Install burner (refer to 9.2.3.2).
3. Install temperature limiter (refer to 9.2.1.2).
4. Install temperature sensor (refer to 9.2.2.2).

9.2.11 Combustion Chamber, Replacement**9.2.11.1 Removal**

1. Disconnect electrical connections to temperature limiter and temperature sensor.
2. Swing burner open (refer to 8.5.2).
3. Withdraw combustion chamber (1, Fig. 905) from heat exchanger (2) and remove.
4. Perform procedures on components after disassembly (refer to 9.1.1).

9.2.11.2 Installation

1. Slide combustion chamber (1, Fig. 905) fully into heat exchanger (2) against stop.
2. Swing burner closed (refer to 8.5.2).

NOTE

Observe electrical wiring color coding when making connections.

3. Make electrical connections to temperature limiter and to temperature sensor.

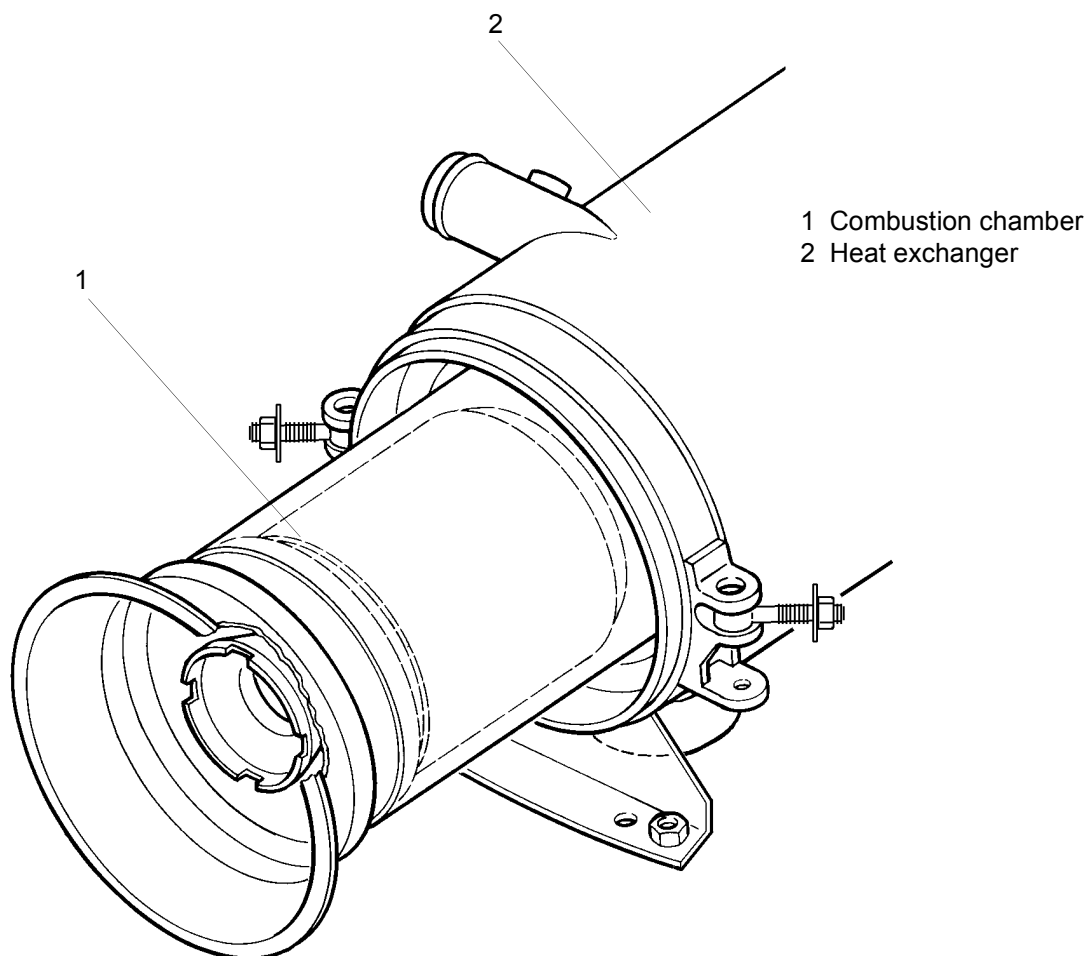

Fig. 905 Heat Exchanger and Combustion Chamber, Replacement

10 Packaging, Storage and Shipping

10.1 General

The heater or its components shipped to Webasto AG for testing or repair must be cleaned and packaged so that they are protected against damage during handling, shipping and storage.

CAUTION

When shipping a complete heater assembly it must be drained completely. No coolant is allowed to escape when packaging or shipping.

Dummy plugs must be fitted to the coolant inlet and outlet as well as to the fuel lines.

In storage the ambient temperatures specified in Section 4 must not be exceeded.

Annex A

Scheduled Maintenance

Heater, Scheduled Maintenance

The heater should be checked in regular intervals at least at the beginning of the heating season (point of time when weather conditions cause increased use of heater).

The maintenance intervals indicated below apply to applications and requirements typical of busses. Should the heaters be used in other vehicles or applications, these intervals may have to be adapted, i.e. shortened or extended.

In these cases, please contact your Webasto partner charge.

Check / Maintenance	Important Notes	Check Result		Measured Values, Maintenance / Repair performed
		o.k.	not o.k.	
1. Electrical connections a) Disconnect electrical connectors to cable harness, inspect for oxidation, spray and reconnect after performing step 5. b) Inspect fuses for oxidation and/or check transition resistances.	Use suitable contact spray, e.g. special contact spray (order no. 101322).	<input type="checkbox"/>	<input type="checkbox"/>	
2. Heat exchanger a) Inspect paint for dark stains of burn (local overheating). b) Check for signs of leakage. c) Clean heater exterior and interior.	If necessary investigate reason for overheating (e.g. water circuit). Check temperature limiter.	<input type="checkbox"/>	<input type="checkbox"/>	
3. Fuel system a) Check fuel lines and connections for leaks. b) Replace fuel filter cartridge with gasket. c) If existing, open fuel shut-off cocks. d) Fuel pump and fuel lines. e) Replace fuel filter screen with gaskets in pump.	Check for tight connections in fuel supply and return! Retighten joints and hose clamps. Replace pump and lines every 5 years.	<input type="checkbox"/>	<input type="checkbox"/>	
4. Burner head a) Check combustion air inlet for contamination. Swing burner head open: b) Check cover for damage c) Check housing interior for accumulation of fuel caused by leaks. d) Clean viewing glass of flame sensor. e) Check igniter electrodes for condition. f) Replace nozzle.	Replace damaged cover Replace bent electrodes. When coked reduce replacement interval for fuel filter.	<input type="checkbox"/>	<input type="checkbox"/>	
5. Exhaust system a) Check exhaust line for contamination and clean as required. b) Remove combustion chamber from heat exchanger, inspect both components for damage and contamination and clean or replace as required. c) Insert combustion chamber and mount burner head. Check for secure connection to heat exchanger. d) Restore electrical connections.		<input type="checkbox"/>	<input type="checkbox"/>	
6. Water system a) If installed, clean water filter. b) If installed, open water shut-off cocks.		<input type="checkbox"/>	<input type="checkbox"/>	
7. Functional checks a) If installed, open shut-off cock in return line. b) Check heater function. c) Check for smoke emissions in run-down; replace nozzle if required.	after at least 10 min. of heating operation.	<input type="checkbox"/>	<input type="checkbox"/>	