

Thermo Top C Auxiliary Heating

00 0002

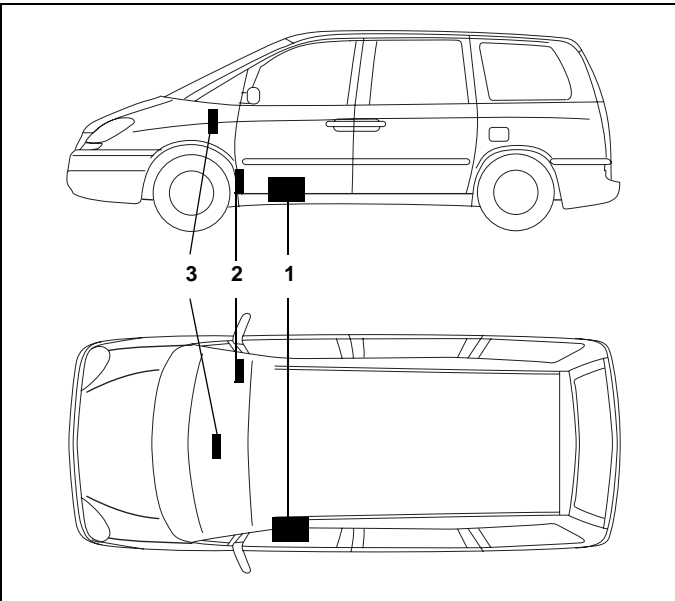

Upgrade to auxiliary heater C

Citroen C8
Fiat Ulysse
Lancia Phedra
Peugeot 807

Diesel

only for left-hand drive vehicles

all models

Legend for figure 1:

- 1 Heater Thermo Top Z -D
- 2 Blade-Type Fuse Holder and Blower Relay
- 3 Time switch

For validity, see page 2



WARNING!

Hazard warning:

Incorrect installation or repair of Webasto heating and cooling systems may cause a fire or result in the emission of carbon monoxide, which can be fatal. Serious or fatal injuries can be caused as a result.

Specialist company training, technical documentation, specialized tools and equipment are required to install and repair Webasto heating and cooling systems.

NEVER attempt to install or repair Webasto heating or cooling systems if you have not successfully completed the company training and thereby acquired the required technical skills or if you do not have access to the required technical documentation, tools and equipment needed to carry out correct installation and repairs.

ALWAYS follow all Webasto installation and repair instructions and observe all warning instructions.

Webasto does not accept any liability for defects and damage that are attributable to an installation by untrained staff.

Thermo Top C

Validity

Manufacturer	Model	Type	EG-BE no.
Fiat	Ulysse	V9	e2*98/14*0255*..
Lancia	Phedra	V9	e2*98/14*0255*..
Peugeot	807	V/G9	e2*98/14*0254*..
Citroen	C8	V/G9	e2*98/14*0254*..

Engine type	Engine model	Power in kW	Engine capacity in cm ³	Air conditioning
4B4H	Diesel	79	1997	Automatic
DW10U	Diesel	88	1997	Automatic
4B4H	Diesel	94	2179	Automatic
RHR	Diesel	100	1998	Automatic

NOTE:

Vehicle types, engine types and equipment variants, which are not listed in these installation instructions, have not been tested. Installation according to these installation instructions may, however, be possible.

Heater unit / Installation kit

Quantity	Name	Order No.
1	Upgrade kit <i>Thermo Top C – D</i> with scope of delivery	1301851C

Foreword

These non-binding upgrade instructions apply to the Citroen C8, Fiat Ulysse, Lancia Phedra, Peugeot 807 - for validity, see page 2002 - from model year and later, assuming technical modifications to the vehicle do not affect installation, any liability claims excluded. Depending on the vehicle version and equipment, modifications may be necessary during installation with respect to these installation instructions.

However, where this is the case the stipulations in the "installation instructions" and "operating and maintenance instructions" for the *Thermo Top C* should be observed. The corresponding recognized rules of technology and any information from the vehicle manufacturer should be observed during the installation work.

Special tools

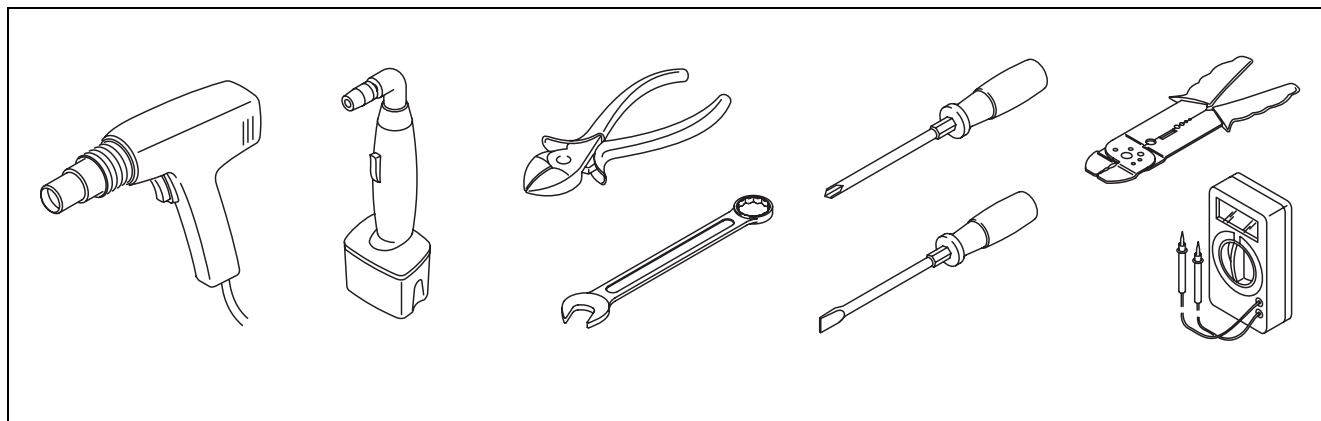

Note:

- Secure hoses, wires, and cable harnesses with cable clips and cover with protective hoses at friction locations.
- Insulate open cable connections

Preliminary work

- Disconnect the battery (see BRE 1000)
- Remove the glove compartment:
- Remove the right section of the heater group
- Remove the left section of the panelling under the dashboard (see BRE 0996 dashboard manual)

Interior

- Place the cable harness in the center console area according to the schematic diagrams and attach this with cable clips.

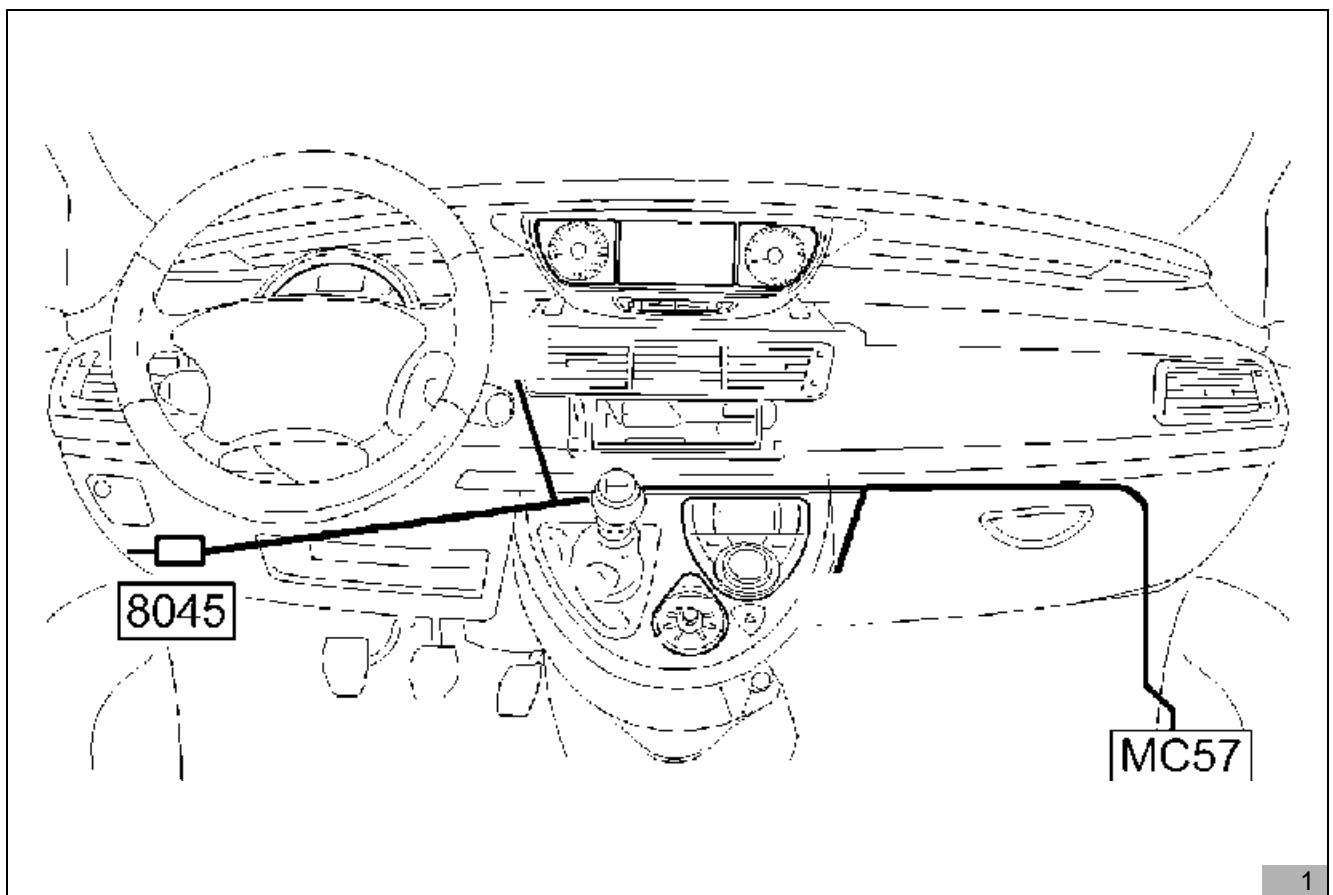

Relay retaining plate

- Fasten the relay retaining plate with the bolts for the servomotor << a >>.

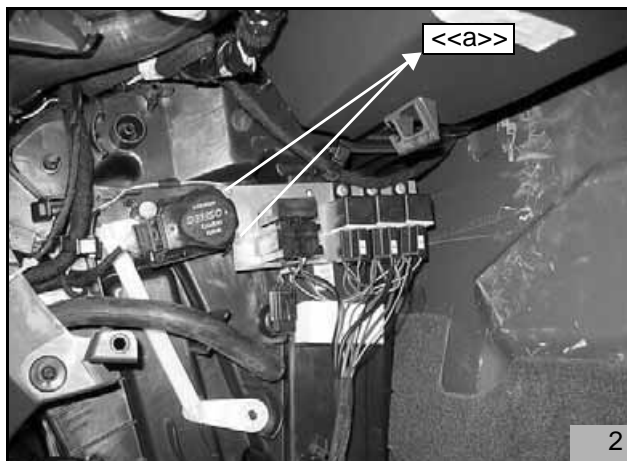

Identify the reserve lines APS C002A and C002D in the vehicle wire harness behind the BSI control unit.

Create connections:

- Wire C002A with VE wire from the K4 relay
- Wire C002D with NR wire from the K4 relay

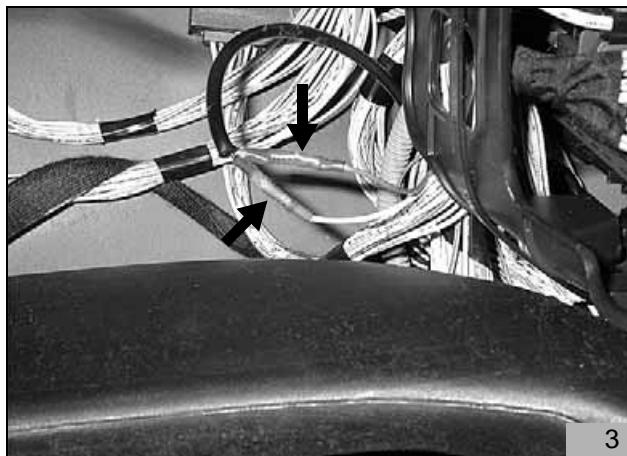

- Connect ground wire to the grounding point MC57 on the vehicle



- Run the cable harness with fuse holder and ground wire to the battery.
- Remove the positive distributor bracket next to the battery compartment.
- Drill a Ø 4 mm bore hole
- Fasten the retaining plate for the fuse holder to the positive distributor bracket with the countersunk screw and the nut.
- Slide the fuse holder onto the retaining plate.
- Connecting the positive wire to the positive terminal.

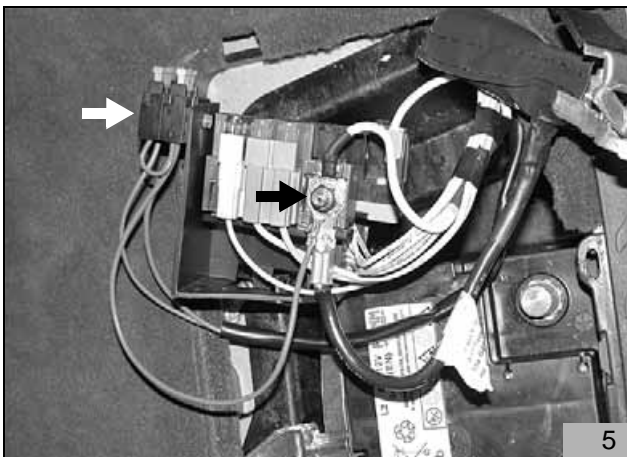

Left side of the vehicle

- Pull the two-pin NR plug from the main blower motor 8045.
- Separate the RG 6 mm² wire.
- Connect the 6 mm² RG wire ends to the adapter cable using the plug connector.
- Connect the 4 mm² NR wire from the K3 relay, terminal 30 with wire RG 4 mm² from the adapter cable using the butt connector.
- Pull the two-pin connector off of the control side.
- Separate the 0.5 mm² JN/NR wire.
- Connect the JN/NR wire to the plug with the NR wire from the IPCU, terminal A.
- Connect the JN/NR wire from the air conditioning control to the RG wire from the IPCU, terminal E.

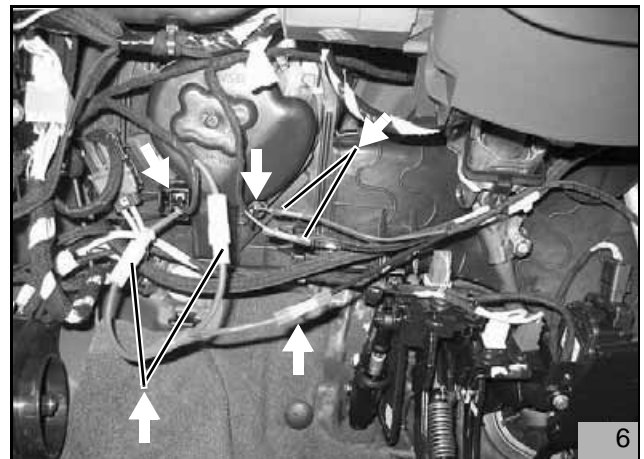

D

Warning:

When installing the time switch, do not press on the LCD display.

Note:

The installation position shown for the timer switch is a recommendation! Before installing, please confirm the installation location with your customer.

- Attach drilling template for the time switch
- Drill two holes as on the template.
- Remove the template.
- Pull the time switch cable harness through the hole.
- Attach connector to time switch.



Note:

To avoid damaging the time switch, do not tighten the self-tapping screw too tightly.

- Fasten the time switch with the self-tapping screw.
- Attach the cover

Thermo Top C

D

- Identify the wires APS C002A and C002D in the wire harness behind the BM34.

Connecting the cable harness:

- Wire C002A to wire VE.
- Wire C002D to wire NR.
- Run the cable harness to the motor controller ECM 1320.
- Secure cable harness with cable ties.



Only for motors 4B4 H and DW 10 U

- Pull the plug 32 V BA off of ECM 1320.

Connecting the cable harness:

- Separate wire BE (8097) to the pin 1C.
- Wire VE to the wire to the plug.
- Wire NR to the wire to the cable harness.

Only with RHR engine

- Pull the plug 32 V NR off of ECM 1320.

Connecting the cable harness:

- Separate wire BE (8097) to the pin B1.
- Wire VE to the wire to the plug.
- Wire NR to the wire to the cable harness.

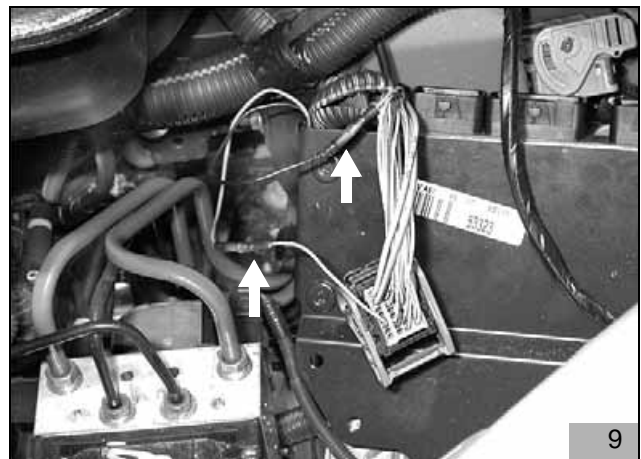

Key to circuit diagram

Cable Colors

BA	white
BE	blue
JN	yellow
MR	brown
NR	black
RG	red
VE	green
JN/NR	Yellow/black

Components

1320	Engine control unit (ECN)
8045	Blower controller
8053 / 8054	Air conditioning control
8099	Auxiliary heater (=Thermo Top Z)
APS	Reserve wire
BSI	Controller
BM34	Relay support in the engine compartment
MC57	Grounding point
BRE 0996	Installation instructions

Circuit diagram

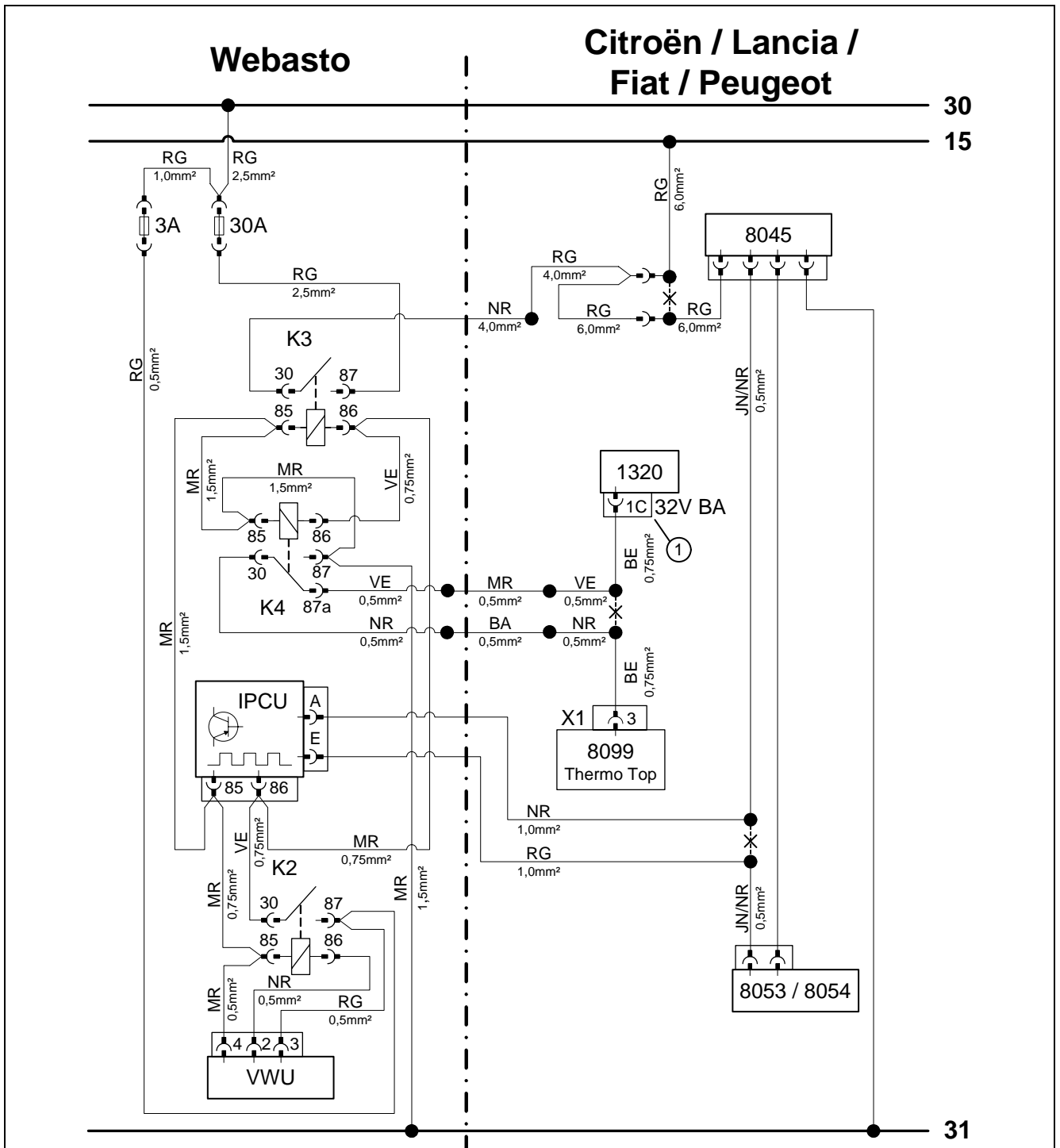

Warning:

① = On vehicles with RHR engines, this is the plug 32C NR / pin B1!

D

Final work

- Reassemble disassembled components in reverse order.
- Check that electrical connections are securely fastened.
- Secure all loose lines using cable clips.
- Disconnect the vehicle battery (see BRE 1000)
- Perform functional check.
- Add the operating manual for the time switch to the operating manual for the vehicle, in the Comfort section.
- Attach the "Switch off auxiliary heating before re-fuelling" sticker onto the left side of the B-pillar.

D