

Auxiliary heating *Thermo Top C* ^{e1} 00 0002

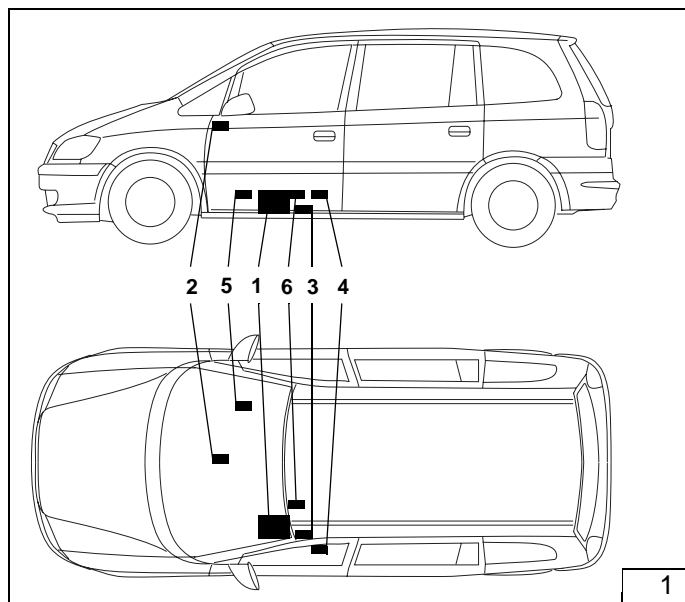

Installation Instructions

Citroën C8
Fiat Ulysse
Lancia Phedra
Peugeot 807

Gasoline

Only for left-hand drive vehicles

all models

For checked vehicles, see page 2

Legend for figure 1:

- 1 Thermo Top C –B heater unit
- 2 Time switch
- 3 Intake silencer
- 4 Metering pump
- 5 Blade-Type Fuse Holder and Blower Relay
- 6 Exhaust silencer

Vehicle types, engine types and equipment variants, which are not listed in these installation instructions, have not been tested.

Special Tools

- Vice-grip wrench
- Torque spanner for 2.0 - 10 Nm
- Riveting nut tool

Table of Contents

Heater Unit / Installation Kit	2	Installing the heater unit	17
Validity	2	Fuel take-off	19
Foreword	2	Connection to the water circuit	21
General Instructions	3	Final work	30
Preliminary Work	3	Operating instructions for the end customer	31
Heater Unit Installation Location	3	Tank mounting template	33
Blade-Type Fuse Holder and Blower Relay	4	Tank extracting device template	34
Blower control	9		
Time Switch and			
Summer / winter switch option	11		
Installing the Heater Unit	12		
Combustion air	16		
Water connection to the heater unit	16		
Exhaust System	16		
Metering pump	17		

Thermo Top C

Heater Unit / Installation Kit

Quantity	Name	Order No.
1	Water heater unit <i>Thermo Top C - B</i>	90604D

Also required:

1	Citroën C8 installation kit <i>Thermo Top C - B</i>	1301813C
---	---	----------

Validity

Manufacturer	Model	Type	EG-BE no.
Citroën	C8	U60	e2*98/14*0254*..
Peugeot	807	U60	e2*98/14*0254*..

Engine type	Engine type	Power in kW	Engine capacity in cm ³
RFN	Otto 16V	100	1997
3FZ	Otto 16V	116	2230
XFW	Otto 24V	150	2946

Manufacturer	Model	Type	EG-BE no.
Fiat	Ulysse	U60	e2*98/14*0255*..
Lancia	Phedra	U60	e2*98/14*0255*..

Engine type	Engine type	Power in kW	Engine capacity in cm ³
RFN	Otto 16V	100	1997
XFW	Otto 24V	150	2946

Foreword

These non-binding installation instructions apply to the Citroën C8, Fiat Ulysse, Lancia Phedra, Peugeot 807 with gasoline engines - for validity, see page 2002 - from model year and later, assuming technical modifications to the vehicle do not affect installation, any liability claims excluded. Depending on the vehicle version and equipment, modifications may be necessary during installation with respect to these installation instructions.

However, where this is the case the stipulations in the "installation instructions" and "operating and maintenance instructions" for the Thermo Top C/E should be observed. The corresponding recognized rules of technology and any information from the vehicle manufacturer should be observed during the installation work.

General Instructions

- Cover unfinished body areas, such as drill holes, with corrosion protection.
- Secure hoses, wires, and cable harnesses with cable clips and cover with protective hoses at friction locations.
- Fit sharp edges with edge protection (split open plastic hose).
- All lengths in millimeters unless otherwise indicated.

Preliminary Work

- Remove years that do not apply from the duplicate label.
- Attach the duplicate label (type label) in a highly visible location.

Engine Compartment

WARNING:

Disconnect the battery.

- Remove the battery.
- Remove the air filter housing and vacuum hose

Vehicle Exterior

- Open the filler cover, release the pressure in the fuel system, close the filler cover.
- Lower tank

Vehicle Passenger Compartment

- Open original vehicle fuse holder in the battery box.
- Remove the entire glove compartment on the passenger side.
- Remove the side panel on the center console in the driver's side and passenger side footwell.
- Remove the steering column panel on the driver's side.
- Fold back the footwell panel on the driver and passenger side

Heater unit installation location

The heater unit (2/1) is installed as shown in figure 2. This is installed flat and along the direction of travel.

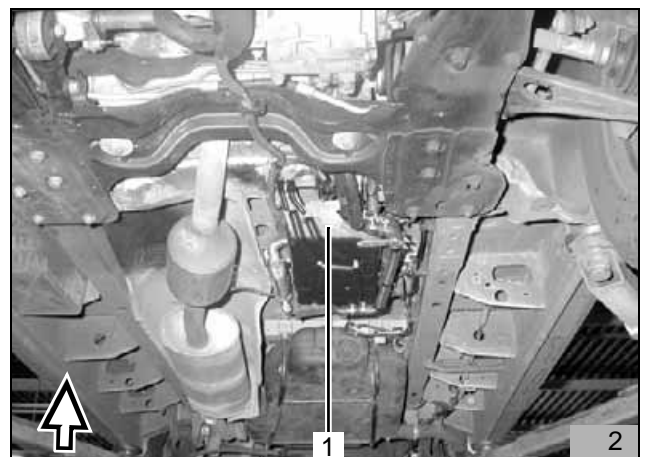

Blade-Type Fuse Holder and Blower Relay

Pre-assembling the Cable Harness

Connect according to figure 3 in the circuit diagram.

Legend for circuit diagram in figure 3:

K3 Webasto blower relay

BE*	blue (from metering pump cable harness)
VE/BA	green/white
RG	red
NR	black
MR	brown
RG/BA*	red/white from fuse F3

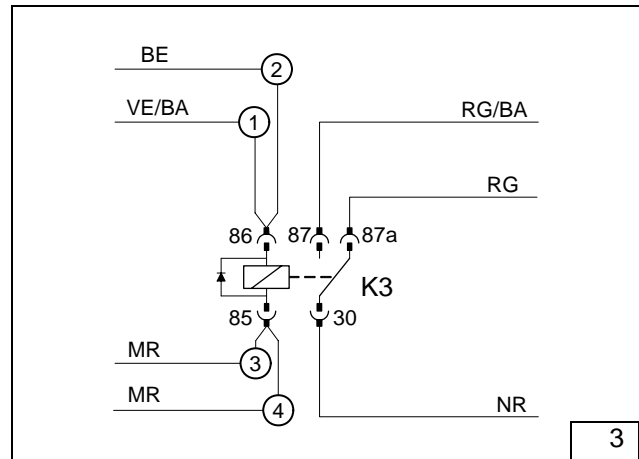

- Cut approx. 2000 mm cable from the metering pump cable harness.
- Uncrimp green/white (gn/ws) wire from the blower relay K3/86 **1**.
- Crimp in green/white (gn/ws) wire together with the blue (bl) wire **2** from the cut off metering pump cable harness in blower relay K3/86.
- Uncrimp the brown (br) wire **3** from the K3/85 blower relay.
- Crimp in brown (br) wire together with the brown (br) wire **4** from the cut off metering pump cable harness in blower relay K3/85.

Assemble the Blade-Type Fuse Holder and Blower Relay

The blade-type fuse holder and the blower relay K3 are installed on the fuse holder in the battery box

- Drill two \varnothing 4mm holes for the blower relay K3 (4/1) and fastening plate for fuse holder (4/2) in the fuse holder as shown in figure 4.

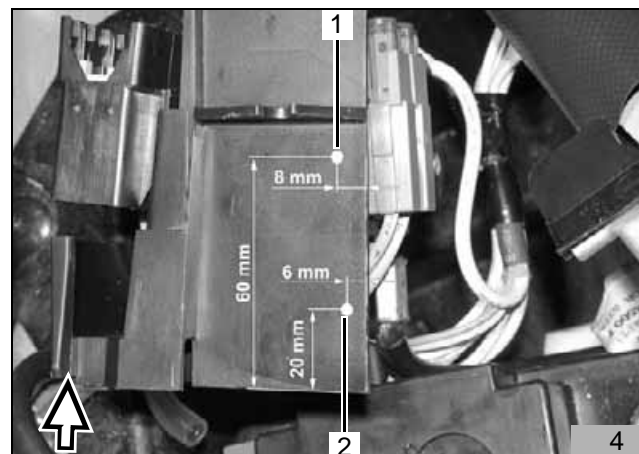

- Fasten the blower relay K3 (5/1) with bolt M4x12 (5/2), washer B5,3 and nut M4 on the fuse holder.
- Fasten the fuse holder fastening plate (5/3) with bolt M4x12 (5/4), two washers B5,3 and nut M4 on the fuse holder.

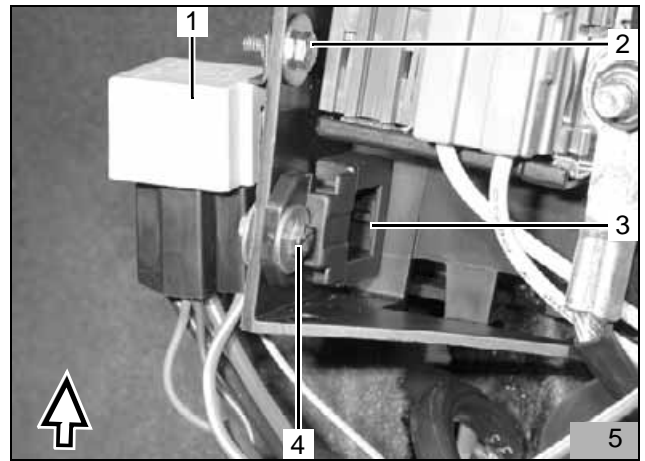

- Mount the fuse holder (6/1) on the mounting plate.
- Reinstall the fuse holder.



- Cut the grounding line (7/1) from the original vehicle grounding point as shown in figure 7 and connect with Ø 6 mm cable socket.
- Reinstall the battery.
- Cut the positive wire to the battery positive terminal and connect with Ø 8 mm cable socket.



Installing the Cable Harnesses

- Run the time switch cable harness (8/3), blower control cable harness (8/2), shortened metering pump cable harness from the blower relay (8/3) along the original vehicle cable lines above the glove compartment to the center console.
- Run the heater unit cable harness (8/6) and the metering pump cable harness (8/5) along the original vehicle cable lines to the left side of the vehicle.



Thermo Top C

NOTE:

Check for the correct polarity.
 Mark the lines to make them more easily identifiable.
 Crimp in the connectors again after the lines have been run along the underbody.

Cable colors for connector X2.	Pin assignment
Red wire	pin 1
Brown wire	pin 2

Cable colors for connector X1.	Pin assignment
Black wire	pin 1
Yellow wire	pin 2
Black wire	pin 3
Green/white wire	pin 4
Purple wire	pin 5
Blue wire	pin 6

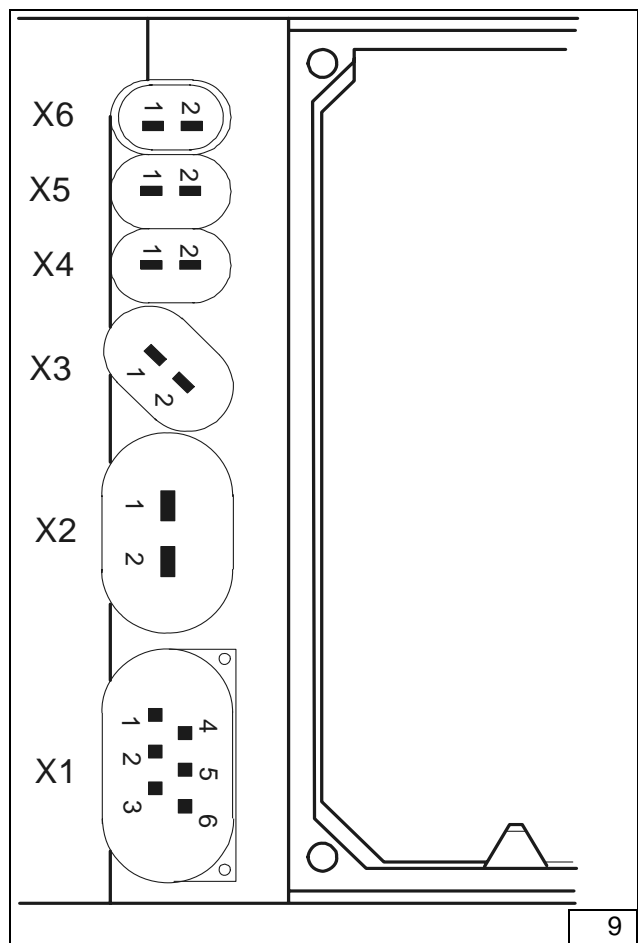

9

- Uncrimp the 2 pin connector X2 from the heater unit cable harness.
- Uncrimp the six pin connector X1 (10/2) from the heater unit cable harness, move the connector catch (10/1) to the right.

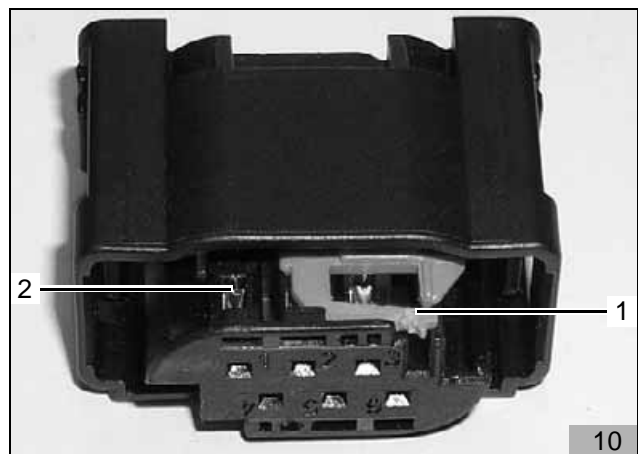

10

- Punch a \varnothing 9 mm hole (11/1) for the heater unit cable harness and **and** a \varnothing 5 mm hole (11/3) for the metering pump cable harness in the enclosed protective rubber sleeve.

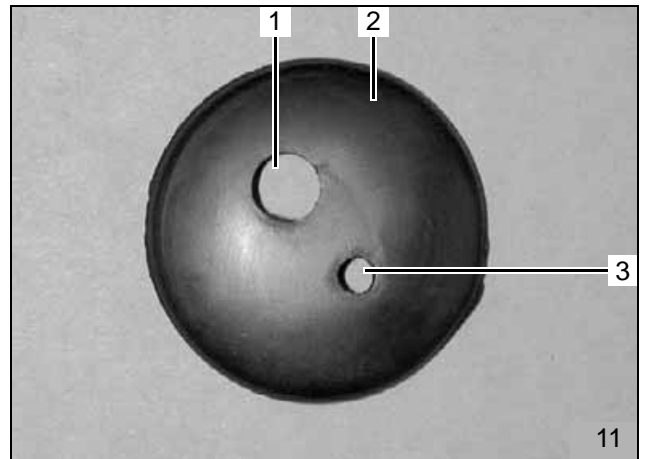

- Cut out the footwell panel in the original vehicle duct (12/1) and press out the stoppers.

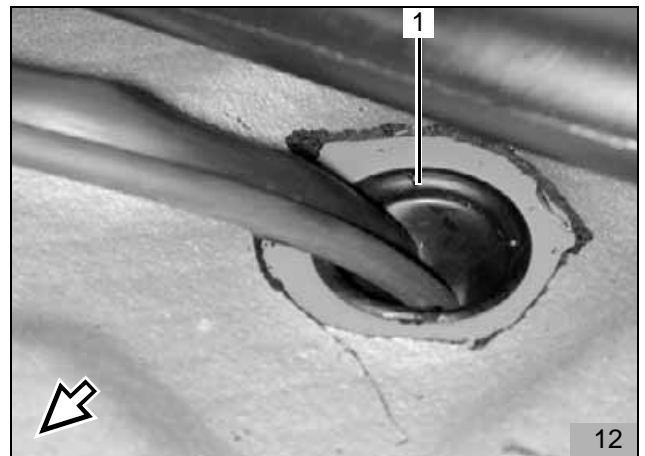

- Insert the heater unit cable harness (13/1) and the metering pump cable harness (13/3) through the original vehicle ducts (13/2).

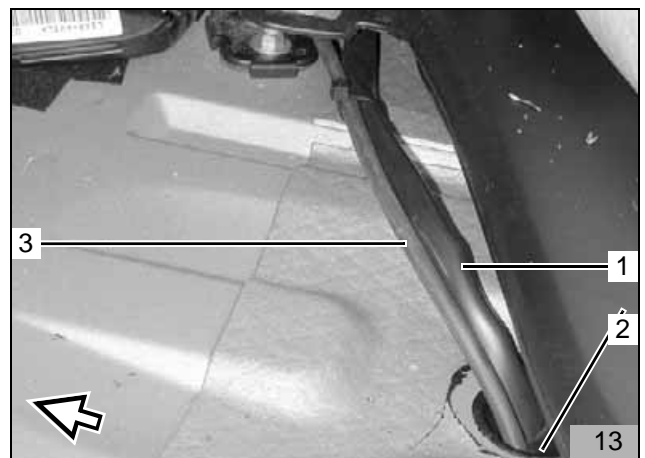

- Slide the protective rubber sleeve (14/1) over the heater unit cable harness (14/3) and the metering pump cable harness (14/2) and insert in the original vehicle ducts from below.
- Reconnect connector X1 and X2 from the heater unit cable harness.

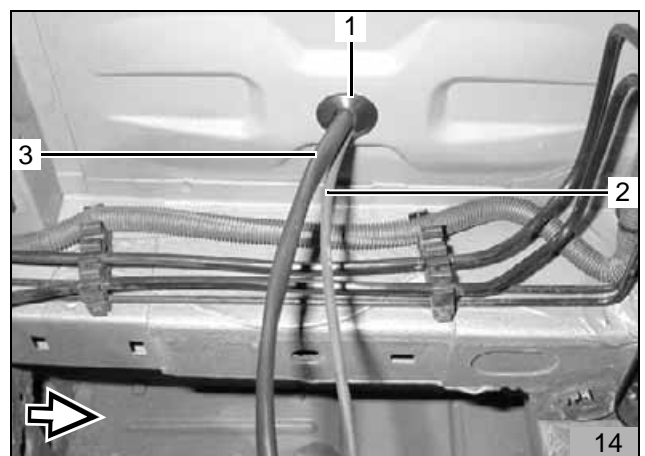

Preparing the IPCU

- Connect with enclosed blade receptacles.
- Connect the blue wire from the blower relay K3/86 (shortened metering pump cable harness) to the IPCU 86(+).
- Connect the brown wire from the blower relay K3/85 (shortened metering pump cable harness) to the IPCU 85(-).
- Connect the additional 1.0 mm black (sw) wire ², 2,000 mm long, to the IPCU (A).
- Connect the second additional 1.0mm² red (rt) wire, 2,000 mm long, to the IPCU (E).
- Pull the red (rt) and black (sw) additional wires from the IPCU into the insulation hose.

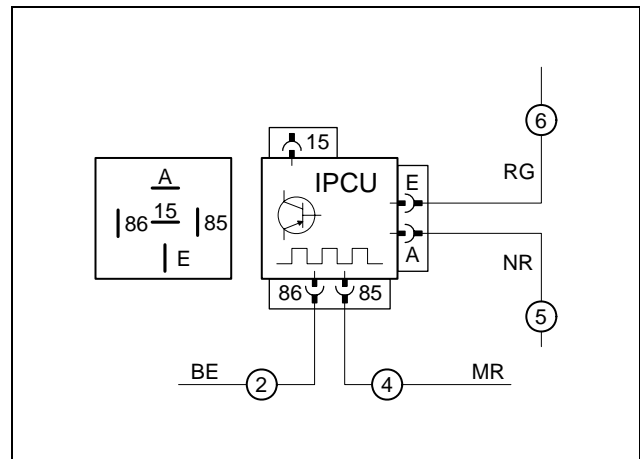

- Fasten the IPCU socket (15/1) to the retaining plate (15/2) with bolts M4x12, washers and M4 nuts.

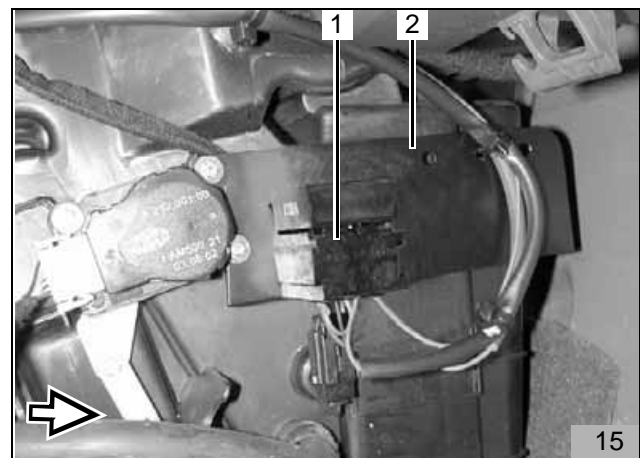

Mounting the IPCU

- Fasten the preassembled retaining plate (16/2) on the bolts (16/3) for the original vehicle motor operator.

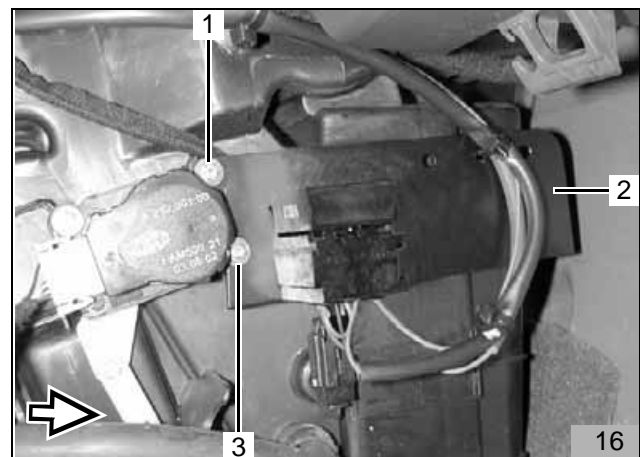

- Fasten the shortened metering pump cable harness (17/1) to the IPCU with the red wire and the black wire (17/2) with cable clips. Run the red wire and the black wire to the left side of the vehicle with the time switch cable harness and the blower connection cable harness.

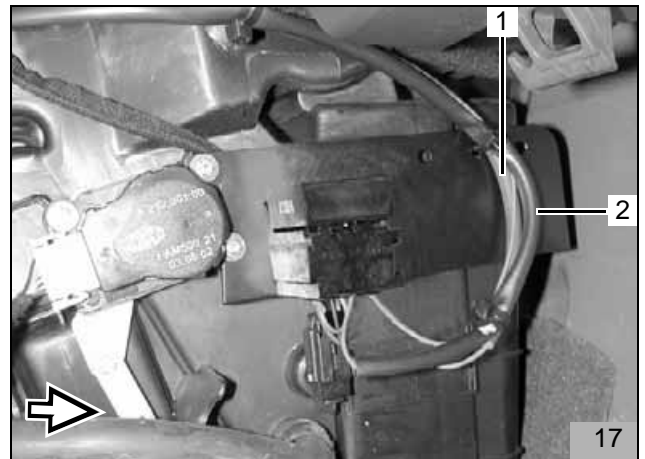

Blower Control

The blower control is connected to the 2-pin NR connector from the blower motor as well as the 2-pin connector from the blower regulator.. Reconnect according to the circuit diagram.

- Pull the two-pin NR connector (18/7) from the main blower motor 8045.
- Separate the 6 mm² RG wire (18/1,6) and connect to the adapter cable with plug connectors.
- Connect the 4 mm² NR wire (18/2) from the K3 relay, terminal 30 with wire RG 4 mm² from the adapter cable using the butt connector.
- Connect the 6 mm² RG wire (18/4,5) with the RG wires (18/1,6) using blade receptacles.
-
- Pull off the two-pin connector (19/1).
- Separate the 0.5 mm² JN/NR wire (19/2,5).
- Connect the JN/NR wire (19/5) to the plug with the NR wire (19/4) from the IPCU, terminal A.
- Connect the JN/NR wire (19/2) from the air conditioning control to the plug with the NR wire (19/3) from the IPCU, terminal E.

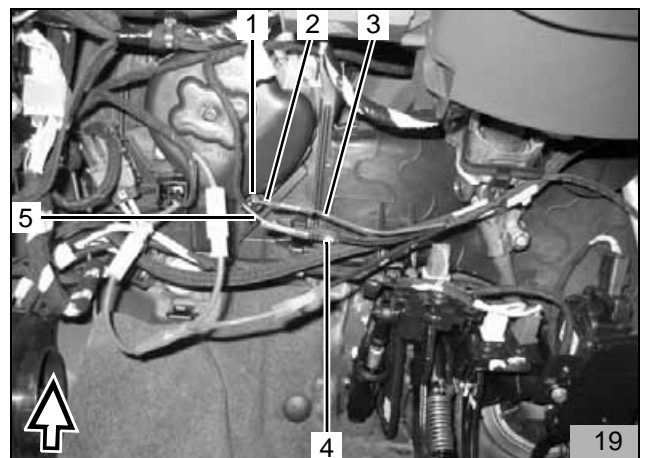
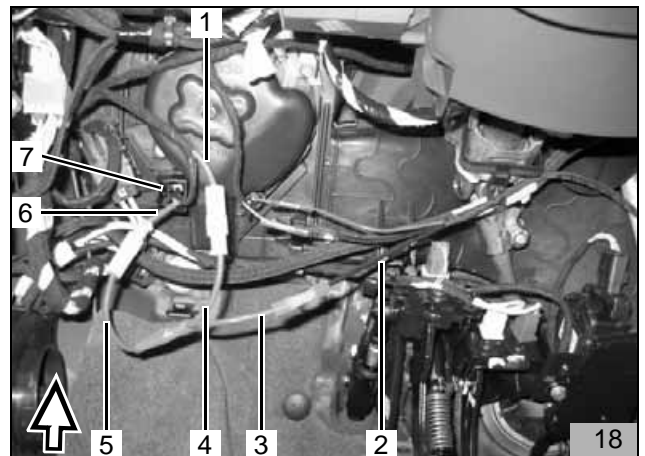

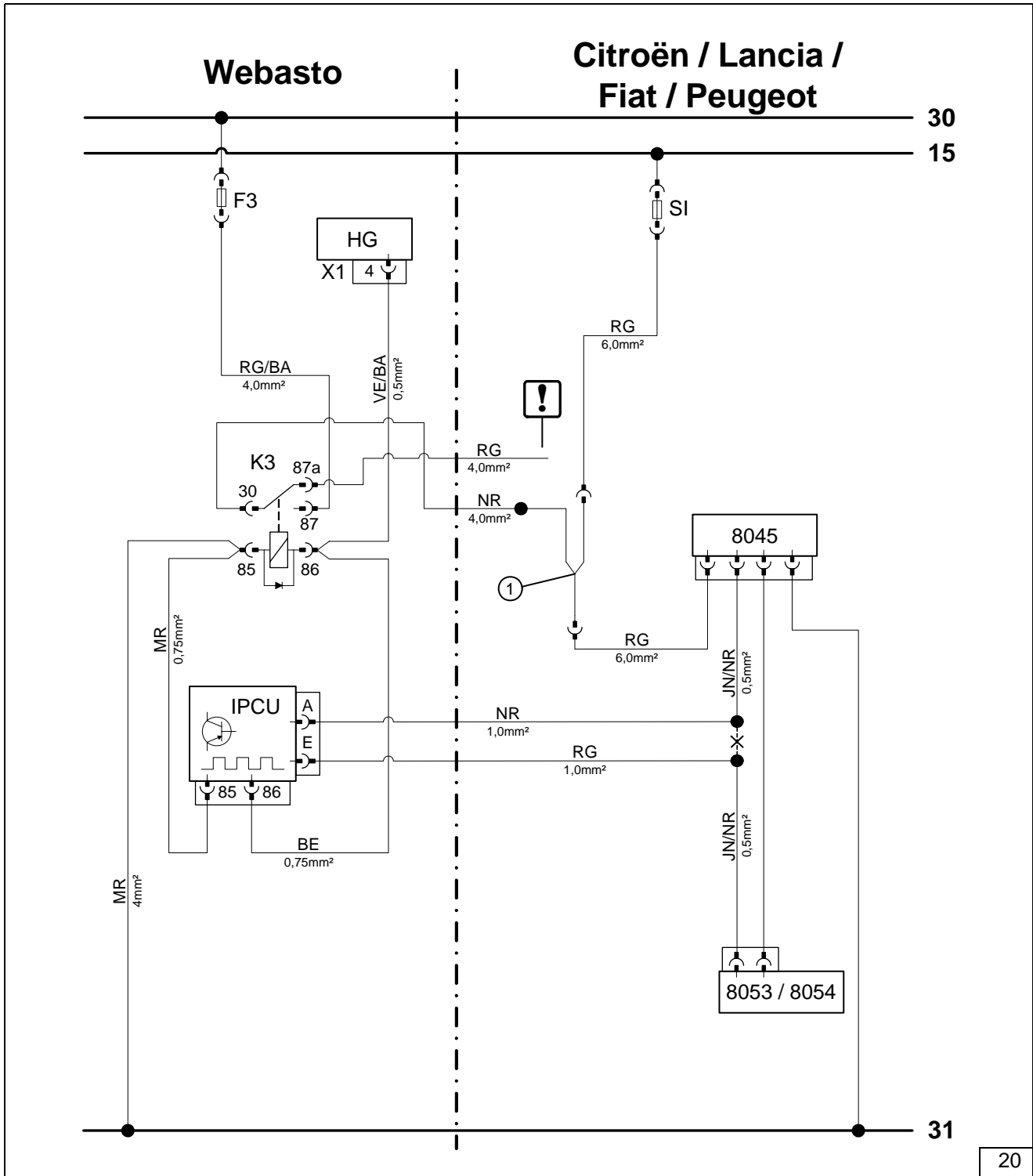

20

Legend for circuit diagram in figure 21:

- HG Heater unit
- K3 Webasto relay K3
- IPCU Impulse width modulator xxx
- F3 Webasto 25A fuse
- SI Original vehicle fuse
- 8045 Blower motor
- 8053/8054 Air conditioning control
- VE/BA green/white
- ① Y-adaptor

- RG/BA red/white
- JN/NR yellow/black
- RG red
- NR black
- MR brown
- BE blue



insulate and tie back wire

Time Switch and Summer / winter switch option

WARNING:

When installing the time switch, do not press on the LCD display.

NOTE:

The installation location shown for the time switch (23/1) and the summer / winter switch (23/2) is a recommendation. Before installing, please confirm the installation location with your customer.

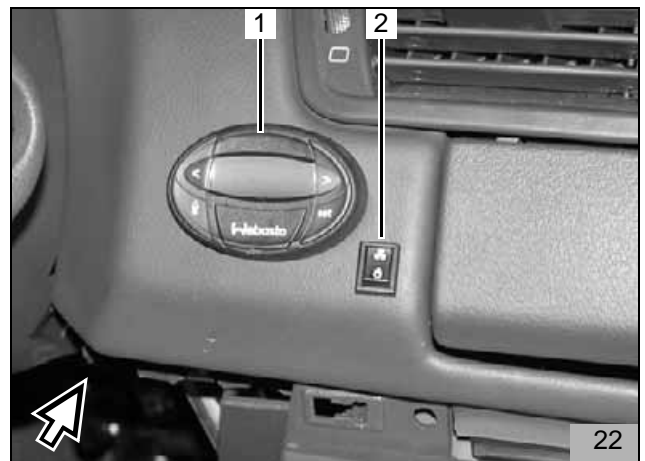

- Attach the drilling template for the time switch (23/1) at the desired position.
- Drill two holes as on the template.
- Remove the template.
- Run the time switch cable harness in the center console to the time switch installation location and pull out through the hole.
- Attach connector to time switch.
- Fasten the time switch with the self-tapping screw.

NOTE:

Note the direction of the catch teeth (see Installation Instructions)! Check for wear protection when placing the cable harness.

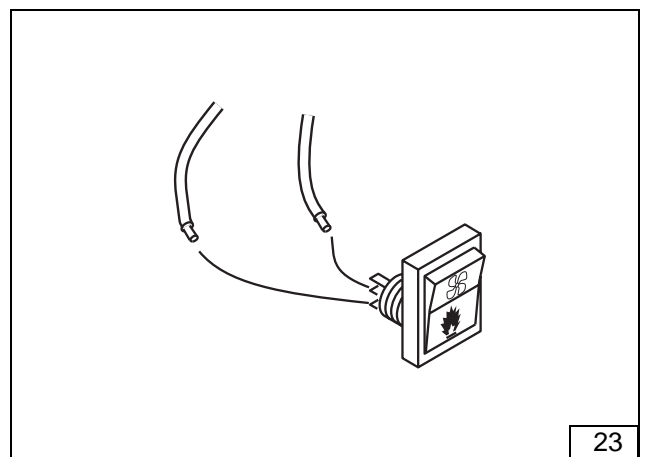

- Run the brown and violet wires through the hole and connect to the switch as shown in figure 24 (lower contacts)
- Fasten the summer / winter switch with the tooth lock washer and nut.

Installing the Heater Unit

Preparing the installation location

Only for vehicles with 2.0 l or 2.2 l engines.

- Remove the bracket (25/2) on the original vehicle cable harness (25/1) at position (25/1) and dispose.

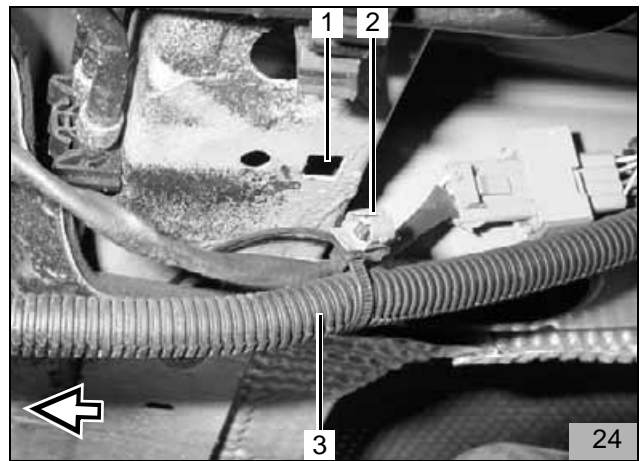

- Remove the original vehicle retaining clip (26/1) from the bracket and set aside.
- Insert the bolt M6x20 (26/3) and body washer in the existing hole (26/2) in the cross rail as shown in figure 26.

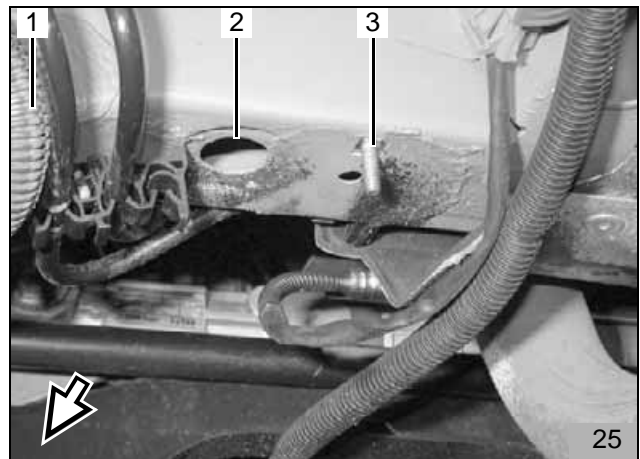

Only for vehicles with 3.0 l V6 engines.

- Remove the bracket (27/3) on the original vehicle cable harness (27/2) from the stay bolts (27/1) and dispose.
- Set the original vehicle cable harness to the side.

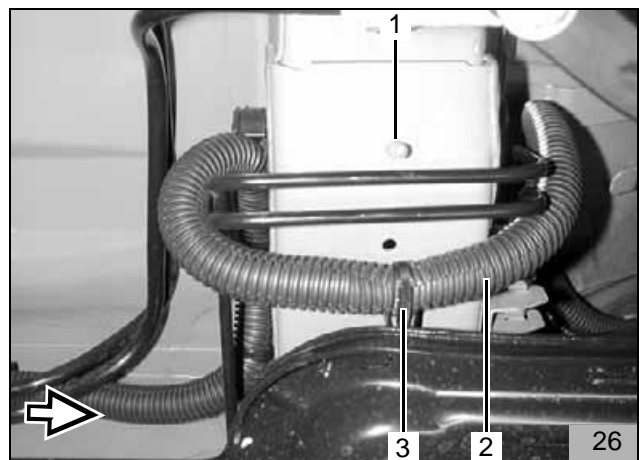

- Loosen the exhaust bracket (28/1)

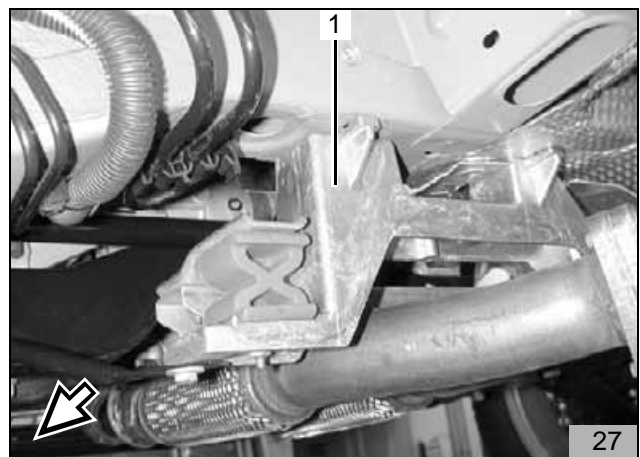

- Drill \varnothing 7mm bore hole (28/2) in the bracket (28/1) as shown in figure 29.

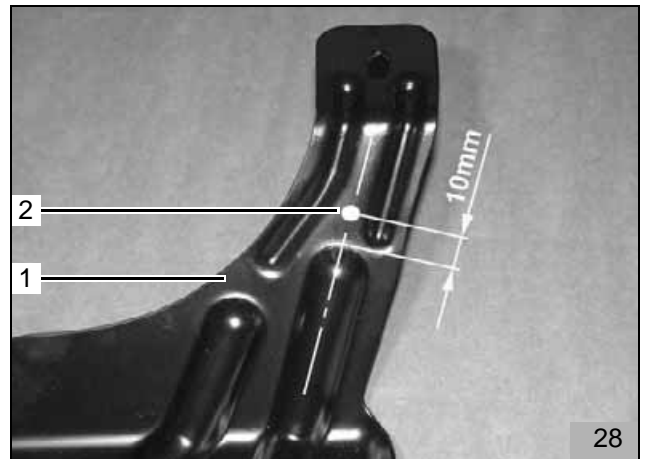

- Bend the enclosed fastening strip (29/1) as shown in figure 30.

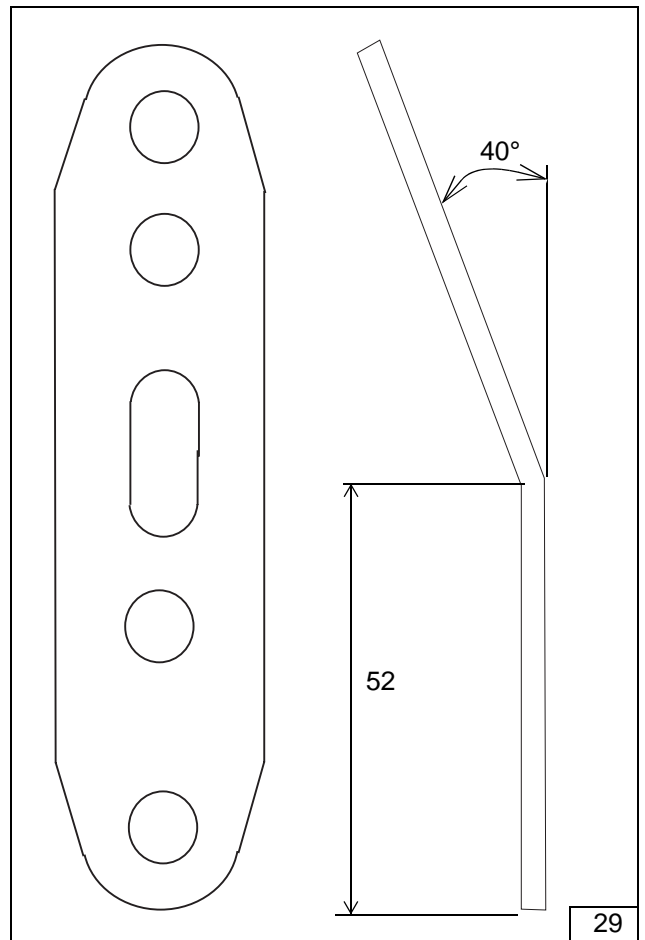

- Tighten the bracket (30/1) to the bracket (31/3) with the M6x20 bolt (30/2) and M6 flanged nut.

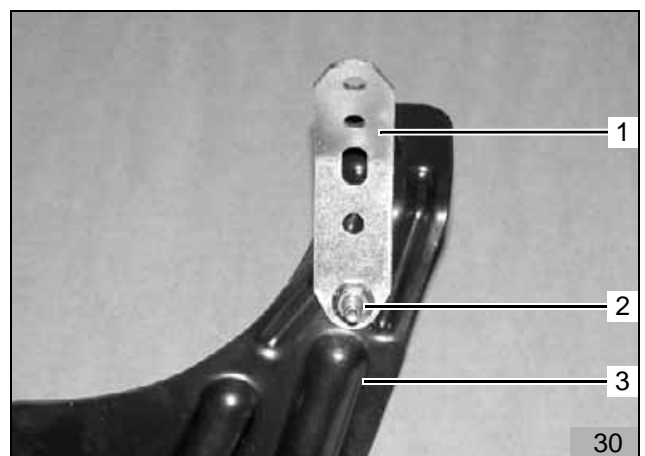

Thermo Top C

- Loosely fasten the bracket (31/1) with M6x20 bolts (31/2,3) and body washers.

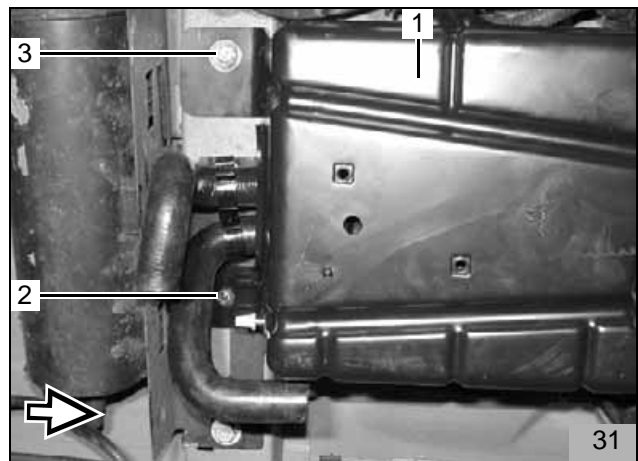

- Position the bracket (32/1) between the exhaust bracket and the cross rail as shown in figure 33.
- Transfer the hole image (32/2) to the cross rail.

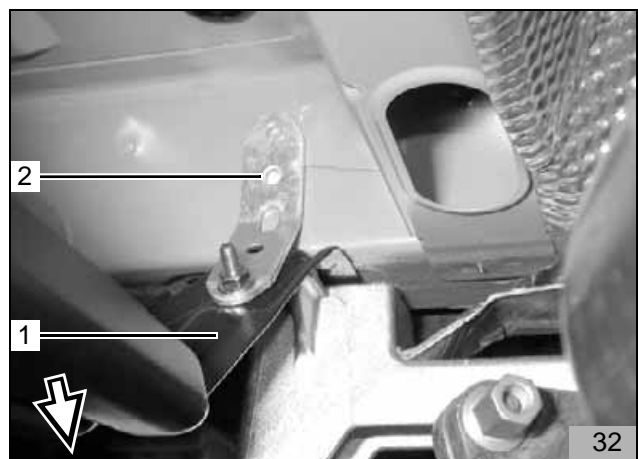

- Remove the bracket, drill \varnothing 9.1 mm hole in the cross rail and tighten the M6 rivet nut (33/1).

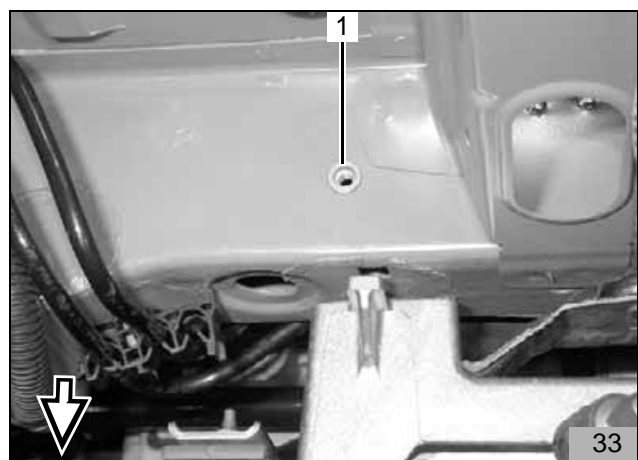

Preparing the Heater Unit

For All Vehicles

- Shorten the enclosed moulded hose (34/1,2) by 10 mm as shown in figure 35.
- Dispose of the hose section (34/1).

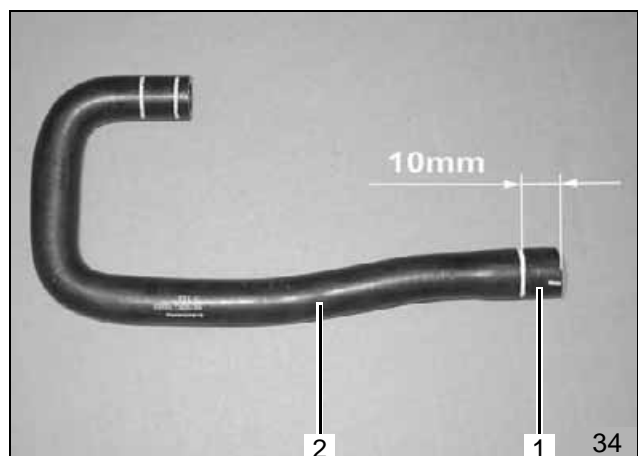

- Pry off the central cover (35/3) on the heater unit
- Separate the circulation pump connection
- Remove the circulation pump (35/1) and the water hose (35/2) on the heater unit.
- Replace the circulation pump cover with the enclosed 193° cover.
- Replace the circulation pump (35/1) and the water hose (35/2) on the heater unit.
- Run the adapter cable harness for the circulation pump on the heater unit plug connection for the circulation pump and through the groove in the heater unit.

NOTE:

When putting on the central cover, make sure that the circulation pump adapter cable harness can move easily.

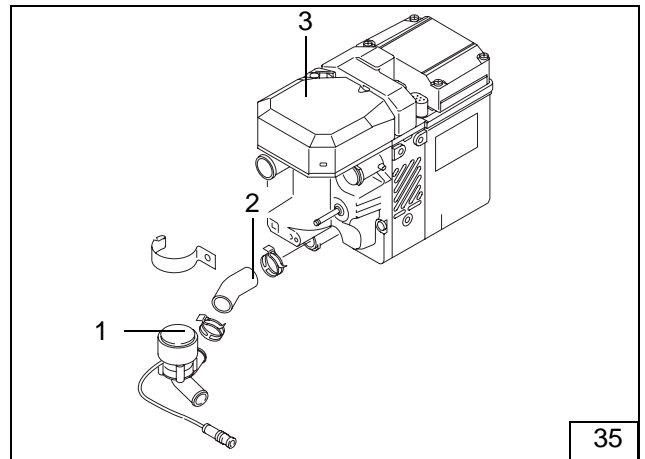

35

- Replace the central cover on the heater unit

NOTE:

Only use the special EJOT PT screws included in the delivery to fasten the bracket. (Tightening torque 10 Nm)

Add two washers between the heater unit and bracket at position (36/3).

- Place the bracket (36/2) on the heater unit and fasten with three ejot screws (36/1,3,4), at position (36/3), insert three washers between the bracket and the heater unit.

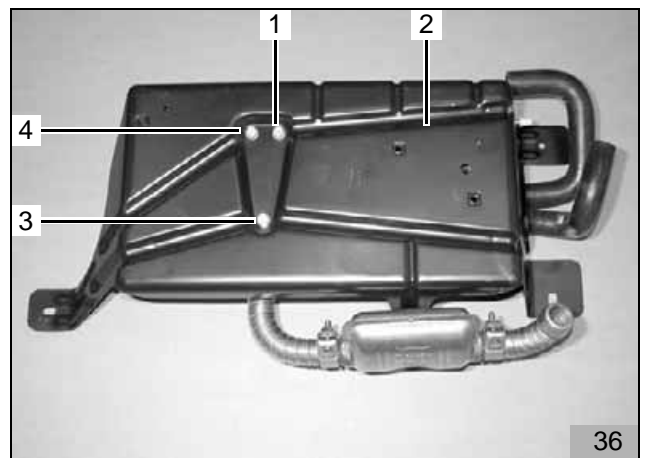

36

- Cut off an edge protection pieces of 280 mm long from the enclosed edge protection.
- Slide the shortened edge protection piece (37/1) on the bracket.



37

Combustion air

NOTE:

Note the installation position of the air intake silencer, see the Installation Instructions.

- Shorten the combustion air intake line (38/1) to 50 mm.
- Turn the combustion air intake silencer (38/2) in to the stop in the combustion air intake line.
- Insert retaining clip (38/3) in the bore hole in the bracket.
- Put the combustion air intake line (38/1) with the cut open side on the heater unit combustion air supports and fasten with the hose clamp.
- Insert the combustion air intake silencer in the retaining clip (38/3) as shown in figure 39.

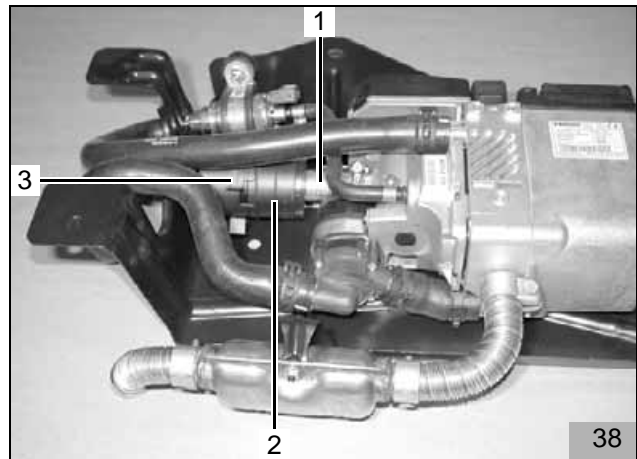

Water connection to the heater unit

- Slide the shortened moulded hose (39/1) onto the heater unit water outlet, align as shown in figure 39 and fasten with spring band clamp.
- Slide the moulded hose (39/2) onto the heater unit water inlet, align as shown in figure 39 and fasten with spring band clamp.

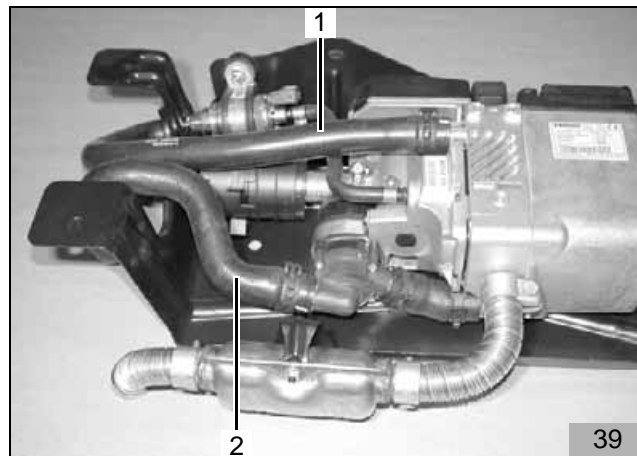

Exhaust System

Cut the supplied exhaust hose into two hose sections as shown in figure 40:

1 x 130 mm (40/1)
(from the heater unit to the silencer exhaust pipe)

1 x 90 mm (40/2)
(from the silencer exhaust pipe to the exhaust outlet)

- A Heater unit
- B Exhaust outlet

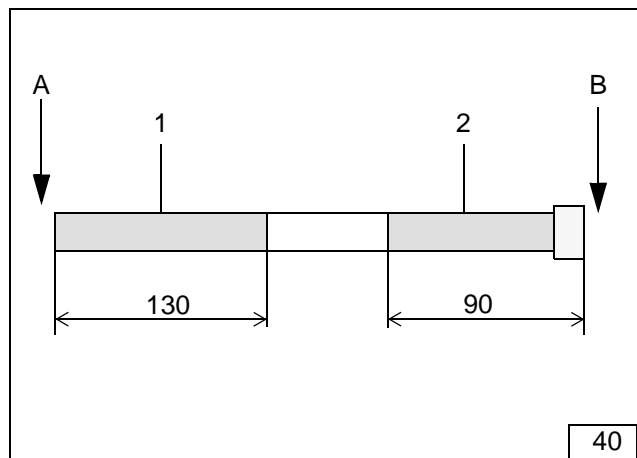

- Fasten the exhaust silencer (41/2) to the stay bolts on the bracket with the flanged nut.
- Slide the 130mm long exhaust pipe (41/1) on the heater unit and the exhaust silencer (41/2) and fasten with hose clamps.
- Shape the exhaust pipe (41) as shown in figure 41
- Put the exhaust pipe end piece (41/3) on the exhaust silencer (41/2) and tighten with the hose clamp
- Shape the exhaust pipe (41/3) as shown in figure 41

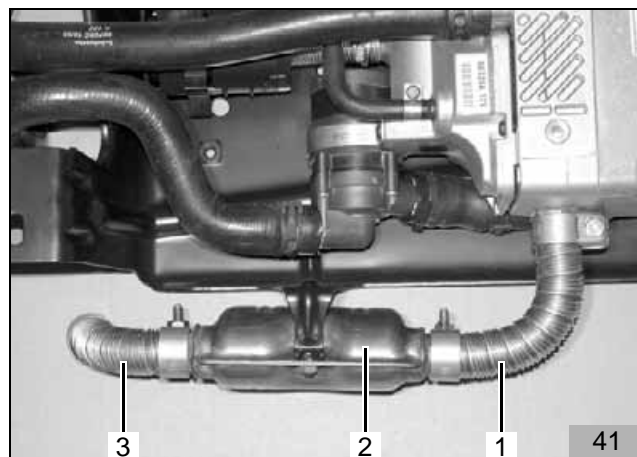

Metering pump

- Insert the silent block (42/4) in the existing bore hole in the bracket.
- Fasten the metering pump (42/1) with rubber tube clamp (42/3), spring washer, and M6 nut to silentblock (42/4).
- Slide the moulded hose (42/2) on the heater unit and on the pressure side of the metering pump (side with connector) as shown in figure 42 and fasten with the 10 mm hose clamps.

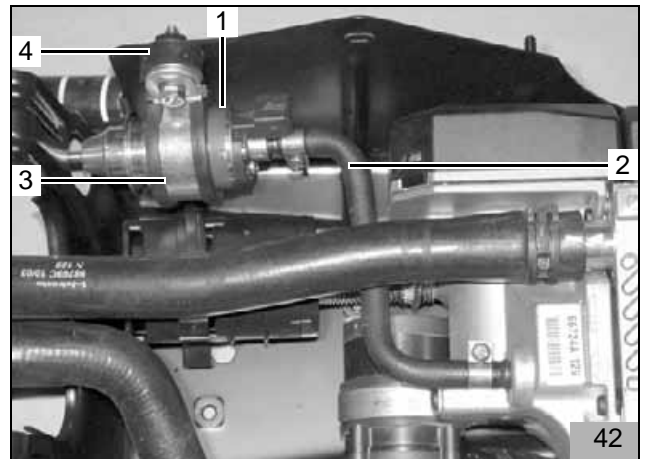

Installing the Heater Unit

- Run the pre-assembled heater unit to the installation location and fasten to the threaded hole on the cross rail with the M6x20 bolt (43/1) and A6 spring washer as well as M6x20 bolt (432) and body washer.

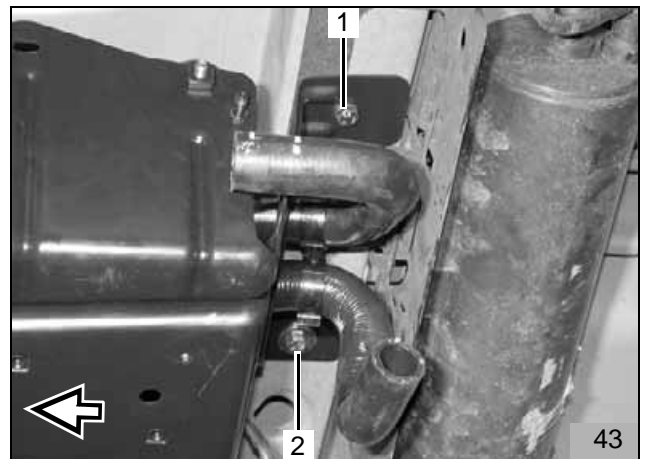

Only for vehicles with 2.0 l or 2.2 l engines.

- Fasten the pre-assembled heater unit on the prepared M6x20 bolt (44/1) with the flanged nut.



- Slide the red rubber profile (45/2) on the exhaust line end section (45/1) and position near the cable harness for the lambda probe (45/3).



Thermo Top C

Only for vehicles with 3.0 I V6 engines.

- Position the bracket (46/1) between the exhaust bracket and the cross rail as shown in figure 46.
- Fasten the fastening strap (46/2) to the prepared rivet nut with the M6x20 bolt (46/3) and the spring washer.

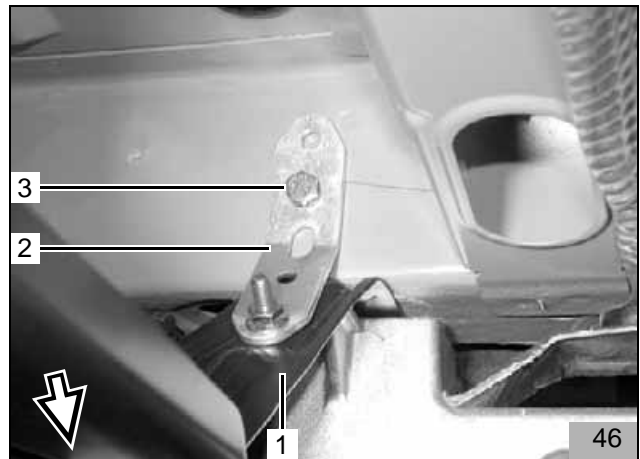

For All Vehicles

- Slide the heater unit cable harness (47/2) on the heater unit
- Cut the metering pump cable harness (47/1) into sections, put on the protective rubber sleeve, crimp on the flat connector, complete the connector housing, and slide onto the metering pump.

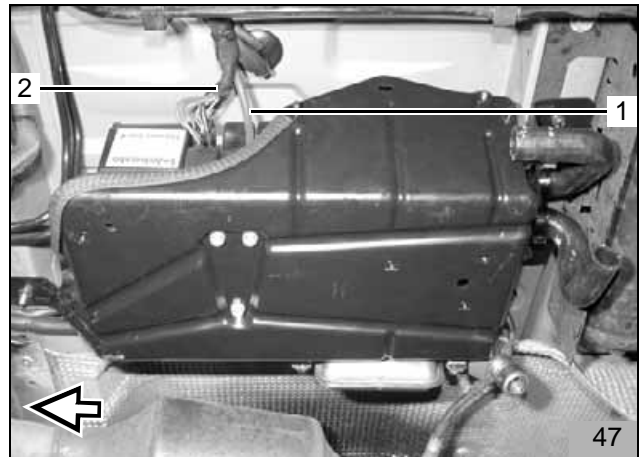

- Fasten the heater unit cable harness (48/2) and the metering pump cable harness (48/1) to the original vehicle lines with cable clips.

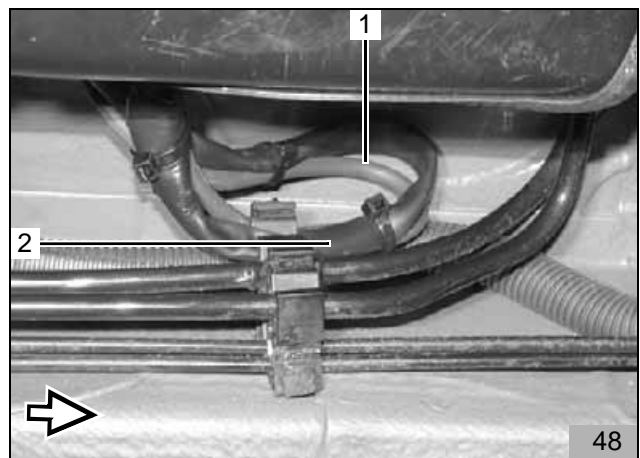

Fuel Take-Off

WARNING:

Open the vehicle's tank-cap lock, ventilate the tank and then re-close the tank-cap lock.

Catch any fuel running off with an appropriate container.

The fuel is extracted with the fuel extractor from the tank mounting.

WARNING:

When drilling, watch out for shavings.

- Lower the tank (four screws)
- Remove tank mounting according to manufacturer's instructions.
- Place the enclosed template (49/2) in the tank mounting as shown in figure 49 and transfer the hole image (49/1).
- Drill \varnothing 6mm bore hole (49/1) in the tank mounting , watch for shavings.

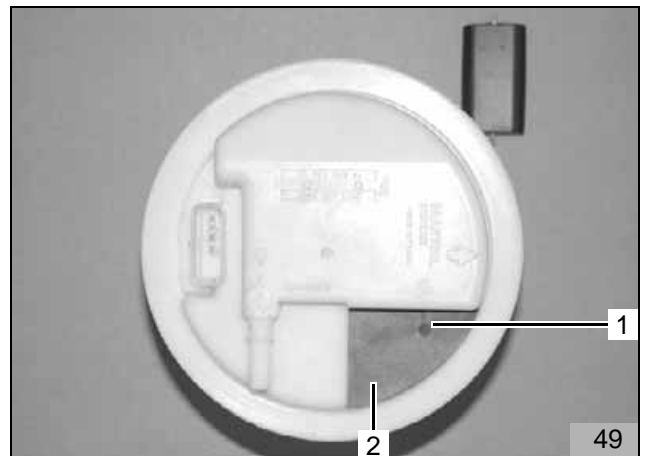

- Bend and cut the tank extracting device (59/1) according to the enclosed template.

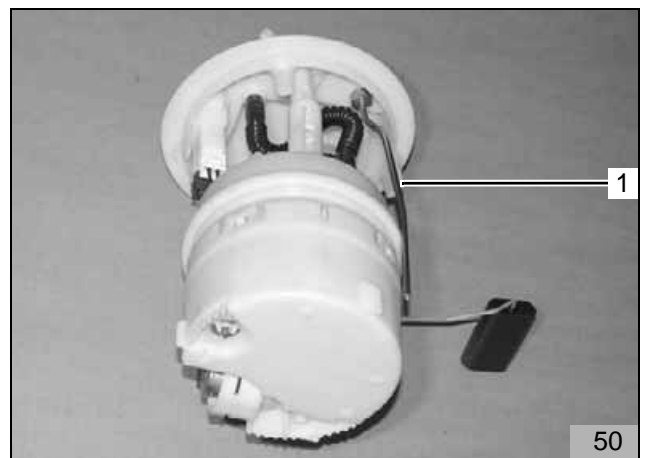

- Insert the tank extracting device (51/1,2) in the tank mounting according to the enclosed installation instructions and tighten.

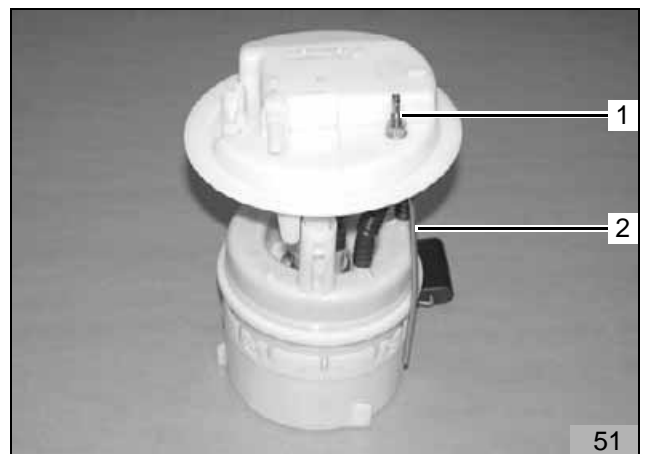

Thermo Top C

- Shorten the enclosed 90° moulded hose (52/1,2)) (inner diameter increasing from Ø 3.5 mm to Ø 4.5mm) on the side with Ø 3.5 mm by 10 mm as shown in figure 52.
- Dispose of the cut off moulded hose section (52/1).

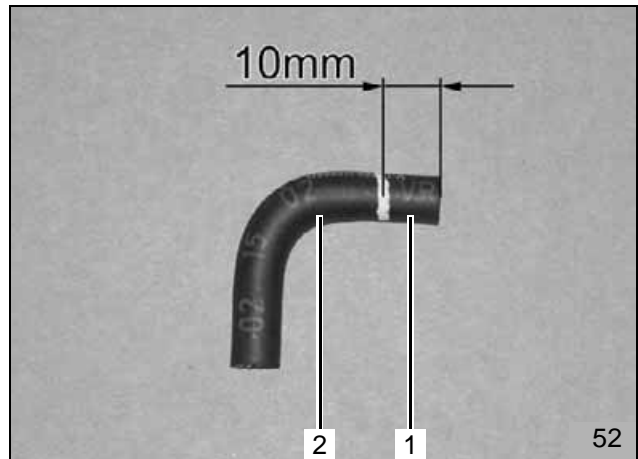

- Slide the moulded hose (53/1) with the Ø 3.5 mm side onto the tank extracting device (53/3) and fasten with the enclosed 9 mm universal clip (53/2) as shown in figure 53.

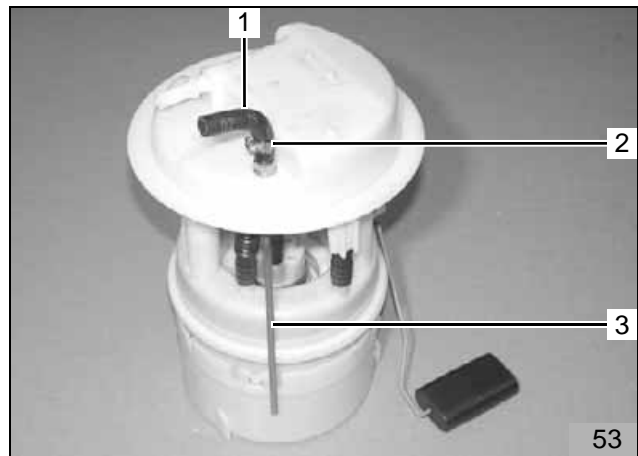

- Install the tank mounting again according to manufacturer's instructions.
- Insert the Mecanyl fuel line (54/2) in the moulded hose (54/1) and fasten with 10 mm universal clamp according to figure 54.
- Reinstall the tank.

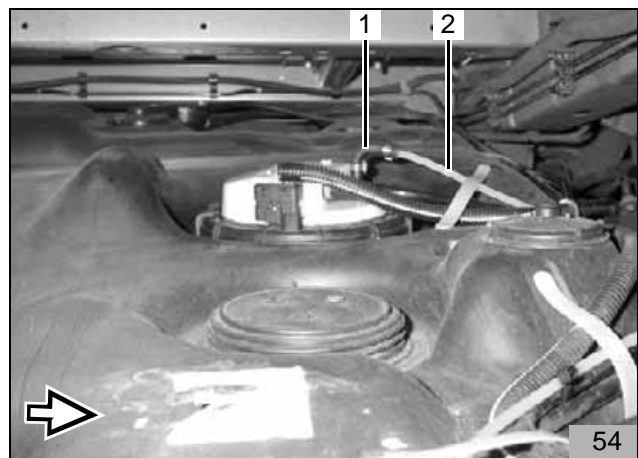

- Run the Mecanyl fuel pipe (55/1,2) along the original vehicle fuel lines to the metering pump and fasten with cable clips.

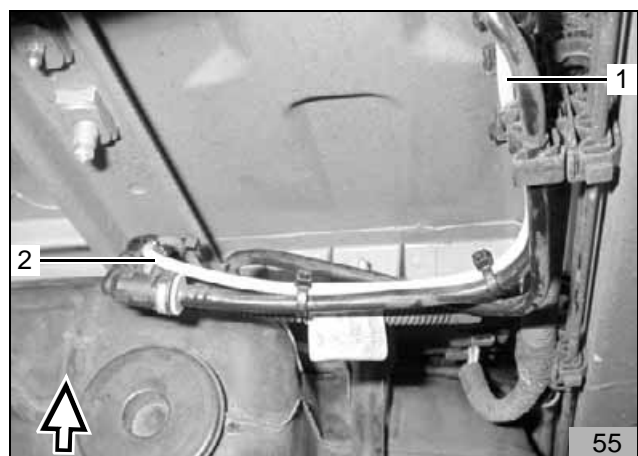

- Cut the Mecanyl fuel line (56/3) on the metering pump into sections and connect with the moulded hose (56/1,2) on the intake side of the metering pump (side without connectors) with 10 mm hose clamps.

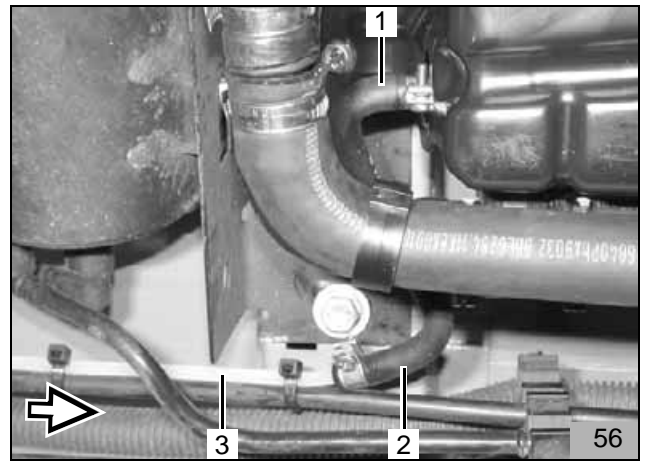

Connection to the water circuit.

NOTE:

Any fuel running off should be collected using an appropriate container!
Route hoses so that they are kink-free.

The following sections describe the installation of the heater unit "inline" in the cooling water circulation of the vehicle (figure 57).

Legend for Figure 57:

- 1 Expansion reservoir
- 2 Coolant thermostat
- 3 Vehicle engine
- 4 Circulation pump (heater unit)
- 5 Heater unit
- 6 Heat exchanger (vehicle)
- 7 Cooler

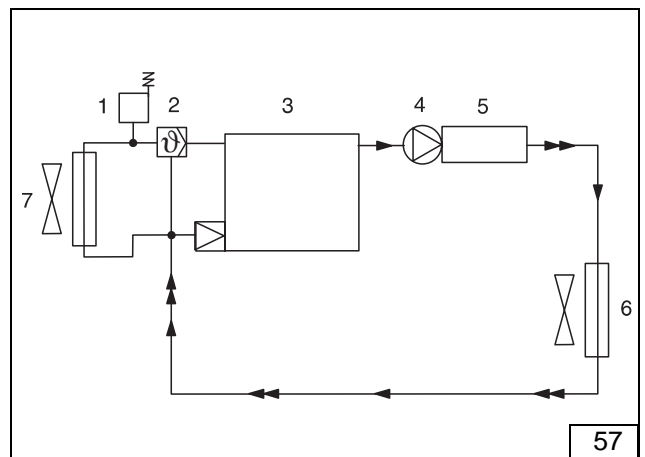

Preparing the Water Connection

Only for vehicles with 2.0 l or 2.2 l engines.

Cut the supplied water hose into two sections, as shown in figure 58:

1 x 290 mm + 90° bend (58/1)
(from the moulded hose heater unit water outlet to the 810mm long water hose (58/2)).

1 x 810 mm + 90° bend (58/2)
(from the 290mm long water hose (59/1) to the original vehicle water hose heat exchanger water inlet).

Cut the second supplied water hose into three sections, as shown in figure 59:

1 x 310 mm + 90° bend (59/1)
(from the moulded hose for the heater unit water inlet to the 90° bend (59/3))

1 x 810 mm + 90° bend (59/2)
(from the 90° bend (60/3) to the original vehicle water hose for the engine exhaust).

1 x 90° bend (59/3)
(from the 310mm long water hose (59/1) to the 810mm long water hose (59/2)).

- Slide on the rest of the edge protection (60/2,3)
- Cut out the heat protection panelling near the water duct (60/1) at the marking (arrow) as shown in figure 61.

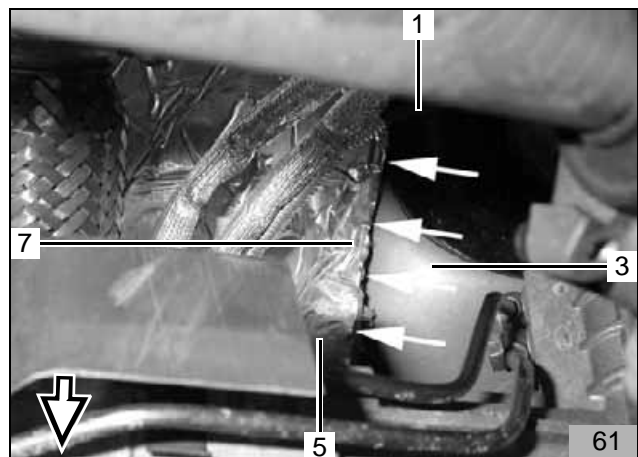
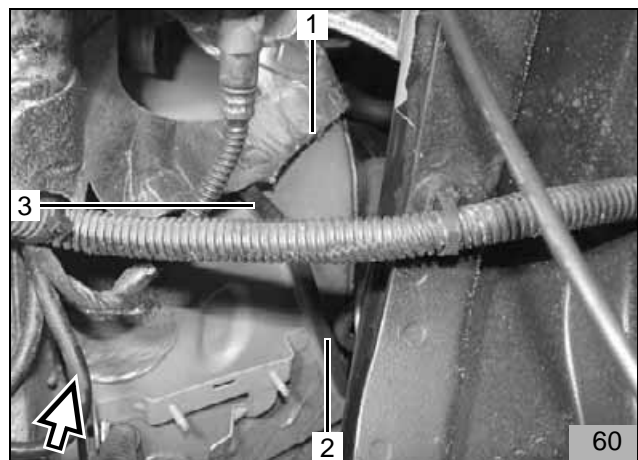
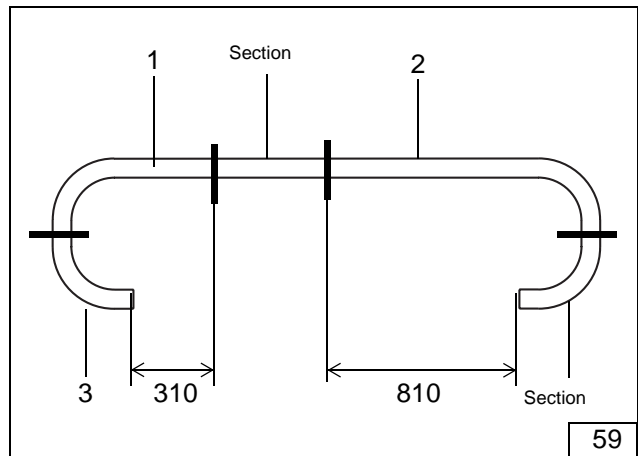
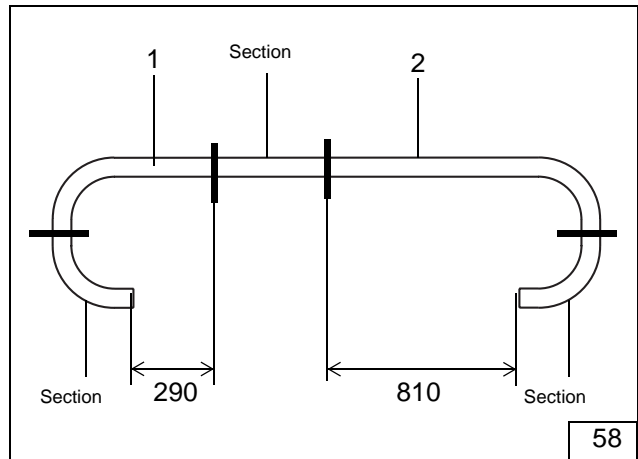

- Drill enclosed angle bracket (62/2) open to \varnothing 8.5mm on the short leg.
- Fasten the drilled bracket (62/2) with M8 nuts to the original vehicle stay bolts (62/1) engine compartment rear bulk as shown in figure 62.



Only for vehicles with 3.0 I V6 engines.

Cut the supplied water hose into two sections, as shown in figure 63:

1 x 290 mm + 90° bend (63/1)
(from the moulded hose heater unit water outlet to the 800mm long water hose (63/2)).

1 x 800 mm + 90° bend (63/2)
(from the 290mm long water hose (63/1) to the 90° angle (63/3)).

1 x 90° bend (63/3)
(from the 800mm long water hose (63/2) to the original vehicle water hose heat exchanger water inlet).

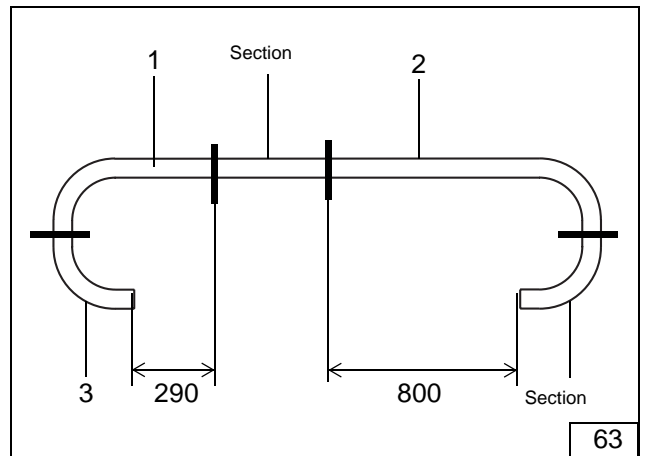

Cut the second supplied water hose into three sections, as shown in figure 64:

1 x 310 mm + 90° bend (64/1)
(from the moulded hose for the heater unit water inlet to the 90° bend (64/3))

1 x 960 mm + 90° bend (64/2)
(from the 90° bend (64/3) to the original vehicle water hose for the engine exhaust).

1 x 90° bend (64/3)
(from the 310mm long water hose (64/1) to the 960mm long water hose (64/2)).

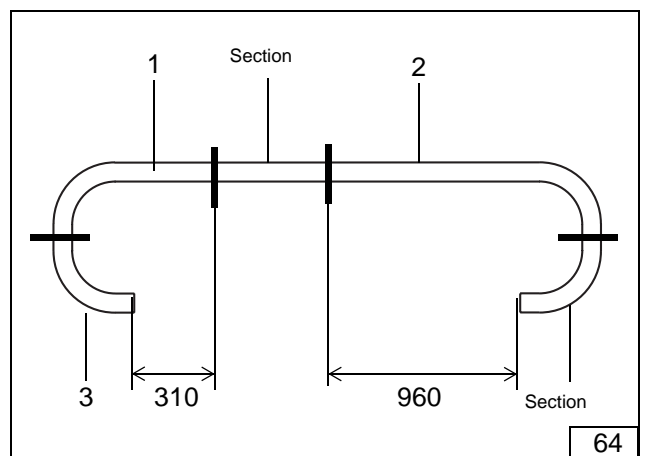

Water Connection

For All Vehicles

- Insert the spacer (65/2) between the moulded hose heater unit water outlet (65/1) and the moulded hose from the heater unit water inlet (65/3).
- Connect the moulded hose from the heater unit water inlet (65/3) and the 90° bend from the 310 mm long water hose (65/4) with the connection tube 18x20 and the hose clamps as shown in figure 65.

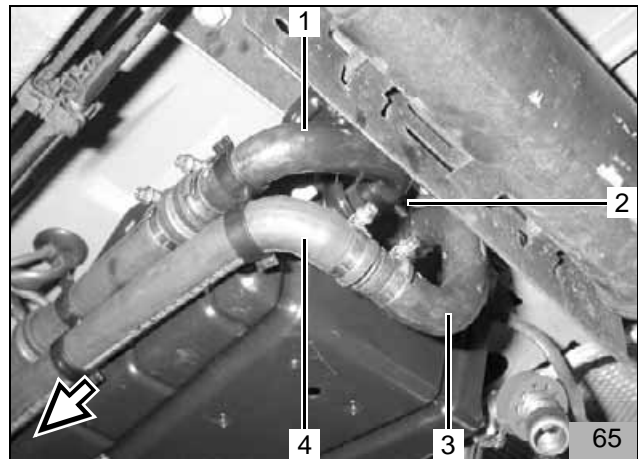

- Connect the moulded hose from the heater unit water outlet (66/3) and the straight end of the 290 mm long water hose (66/3) with the connection tube 18x20 and the hose clamps as shown in figure 66.
- Fasten the 290 mm long water hose (66/3) to the stay bolts on the bracket with rubberised tube clamps (66/1,4) and plastic nuts as shown in figure 66.
- Insert the spacer bracket (66(2,6)) according to the figure.

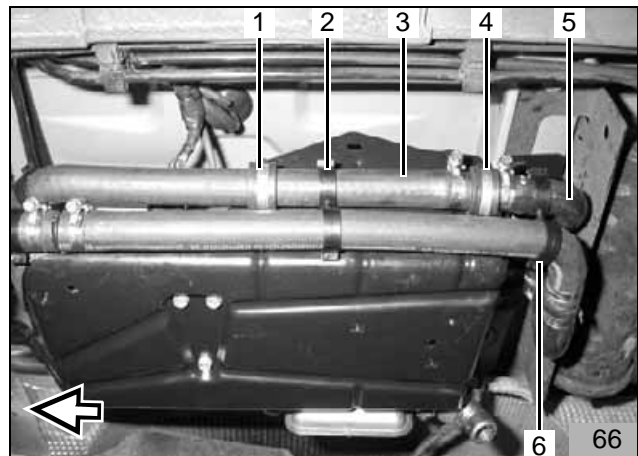

- Connect the 90° bend (67/1) and 310 mm long water hose (68/3) with the 20x20 connecting pipe and hose clamps as shown in figure 67.
- Insert the spacer bracket (67/2) as shown in figure 67.
- Fasten the enclosed fastening strap (67/4) to the prepared threaded hole in the bracket with the M6x20 bolt (67/5) and the spring washer as shown in figure 67.
- Fasten the 90° bend (67/1) to the fastening strap with cable clips.

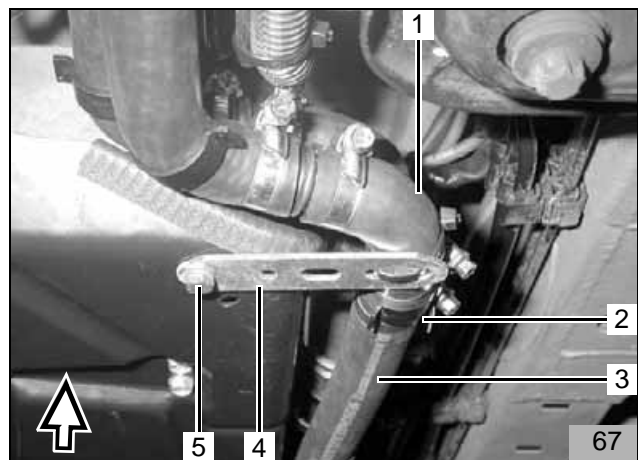

Only for vehicles with 2.0 l or 2.2 l engines.

- Cut the heat protection hose in the middle and slide each section on both 810 mm long water hoses.
- Run both 810 mm long water hoses (68/1,4) with the straight ends to the engine compartment to the splitting point.
- Connect the 810 mm long water hose (68/4) with the 90° bend and the 290 mm long water hose (68/3) with the 20x20 connecting pipe and hose clamps.
- Connect the 90° bend from the 810 mm long water hose (68/1) and the 90° bend (68/2) with the 20x20 connecting pipe and hose clamps.

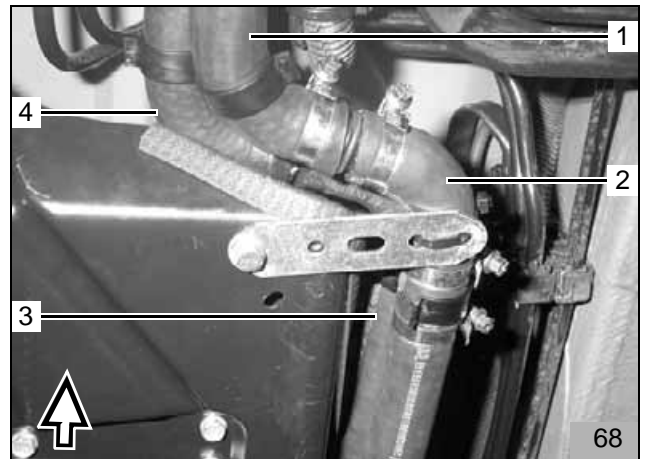

- Fasten the 810mm long water hose (69/1) to the original vehicle stay bolts with rubberised tube clamps (69/2) and plastic nuts.
- Insert the spacer bracket (69/3) as shown in figure 70.

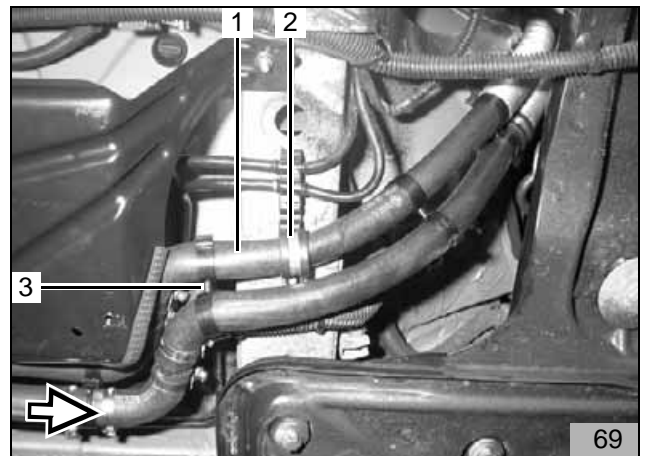

- Bend the fastening strap (70/1) by ca. 10° as shown in figure 70.

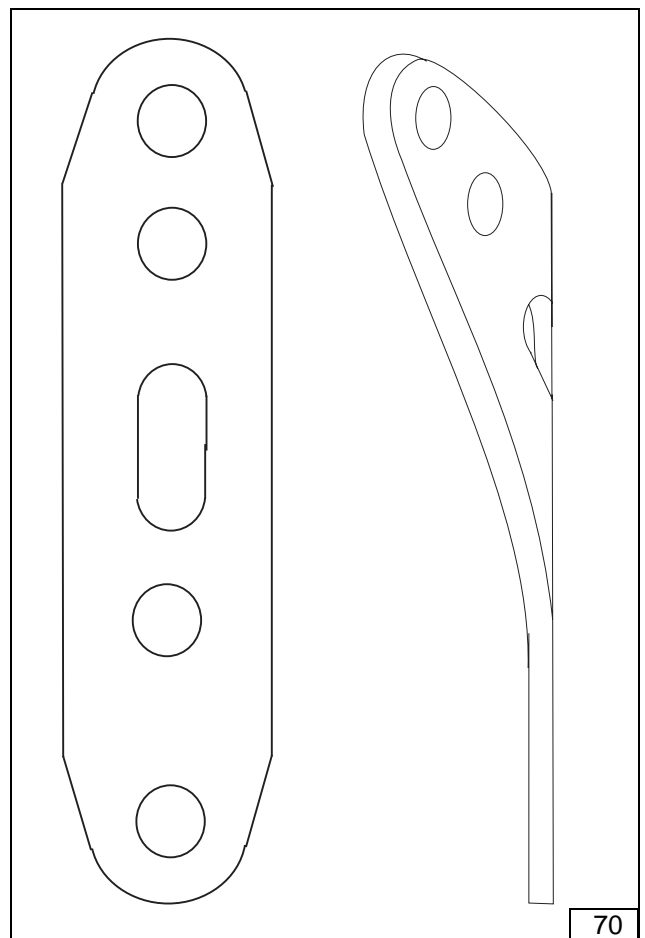

Thermo Top C

- Fasten the twisted fastening strap (71/1) to the original vehicle stay bolt (71/4) with the M6 flanged nut.
- Fasten the 810 mm long water hose (71/3) to the fastening strap (71/1) with the rubberised tube clamp (71/2), M6x20 bolt and M6 flanged nut.

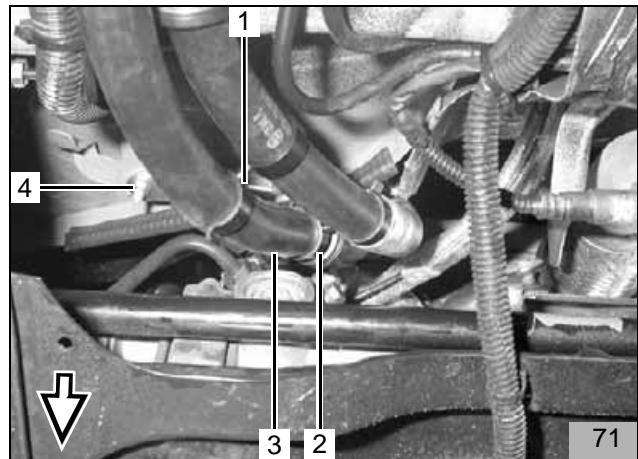

- Insert the spacer bracket (72/1,3) as shown in figure 72.
- Align the heat protection hoses to the rubberised tube clamp (72/2) or the spacer (72/1).

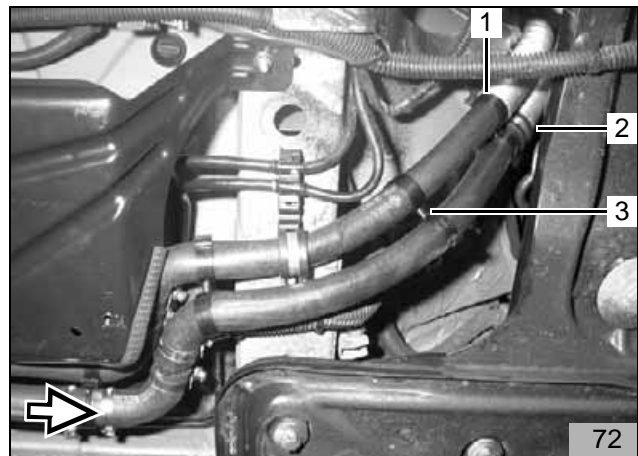

- Fasten the 810 mm long water hose (73/1) to the pre-assembled bracket (73/2) with the rubberised tube clamp (73/4), M6x20 bolt (73/3), body washer and M6 flanged nut as shown in figure 73.

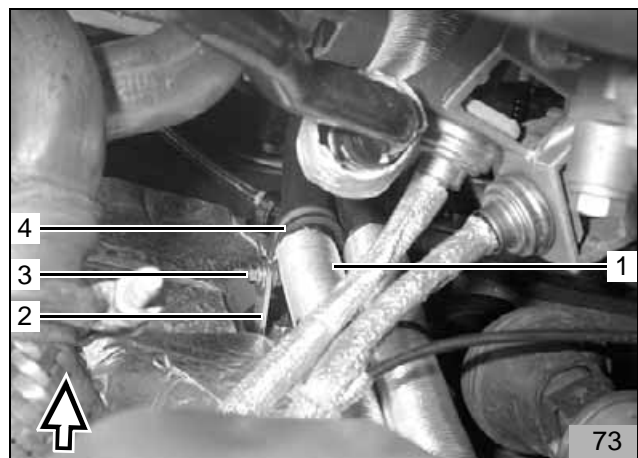

- Clamp the vehicle's own water hose (74/1,2,3) from the engine water outlet to the heat exchanger water inlet with hose clamps.
- Remove the vehicle's own water hose (74/1,2,3) at the markings as shown in figure 74.
- Dispose of the removed hose section (74/2).

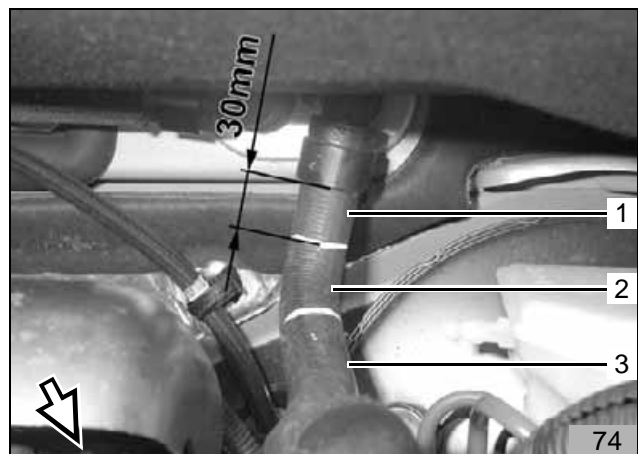

- Connect the 810mm long water hose (75/5) and the original vehicle hose section (75/1) to the heat exchanger water inlet as shown in figure 75 with the 20x20 connecting pipe and hose clamps.
- Connect the 810mm long water hose (75/2) and the original vehicle hose section (75/3) to the heat exchanger water outlet with the 20x20 connecting pipe and the hose clamps as shown in figure 75.
- Insert the spacer bracket (75/4) as shown in figure 75.

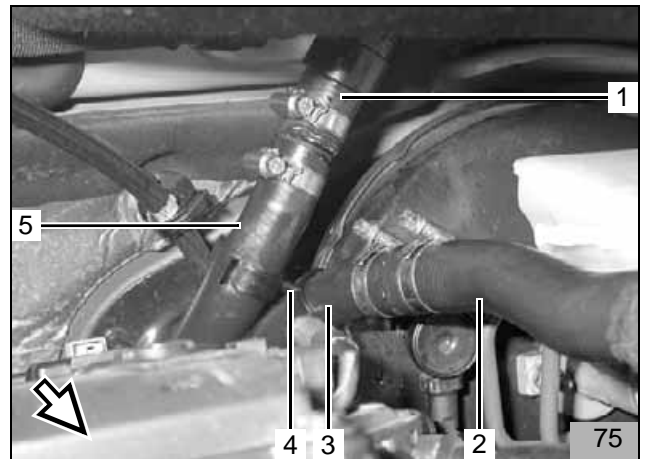

Only for vehicles with 3.0 I V6 engines.

- Run the 800 mm long water hose (76/4) and the 960 mm long water hose (76/1) with the straight ends to the engine compartment to the splitting point.
- Connect the 290 mm long water hose (76/3) and the 90° bend from the 800 mm long water hose (76/4) with the 20x20 connecting pipe and hose clamps.
- Connect the 90° bend from the 960mm long water hose (76/1) and the 90° bend (76/2) with the 20x20 connecting pipe and hose clamps as shown in figure 76.

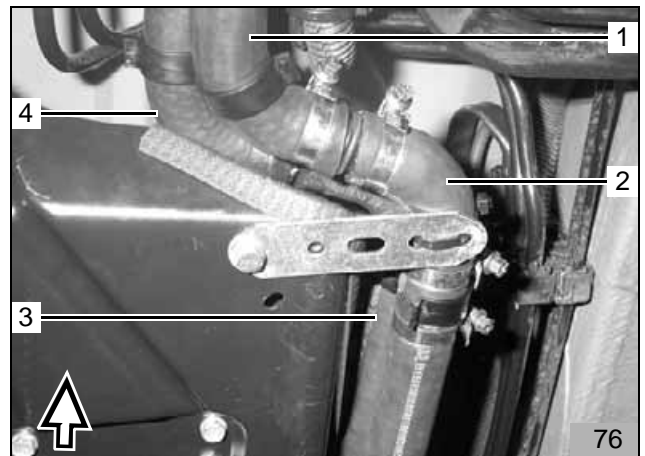

- Fasten the 800mm long water hose (77/1) to the original vehicle stay bolts with rubberised tube clamps (77/3) and plastic nuts.
- Insert the spacer bracket (77/2) as shown in figure 77.

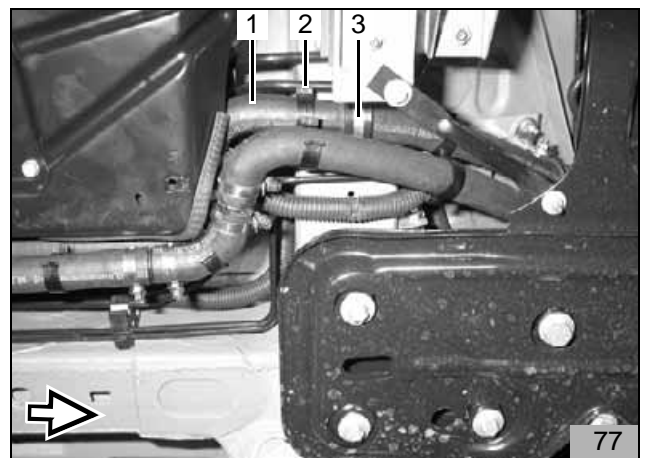

- Fasten the bracket (78/1) to the original vehicle stay bolt (78/2) with the M6 flanged nut.
- Fasten the 800 mm long water hose (78/5) to the bracket (78/1) with the rubberised tube clamp (78/4), M6x20 bolt (78/3) and M6 flanged nut.
- Insert the spacer bracket (78/6) as shown in figure 78.

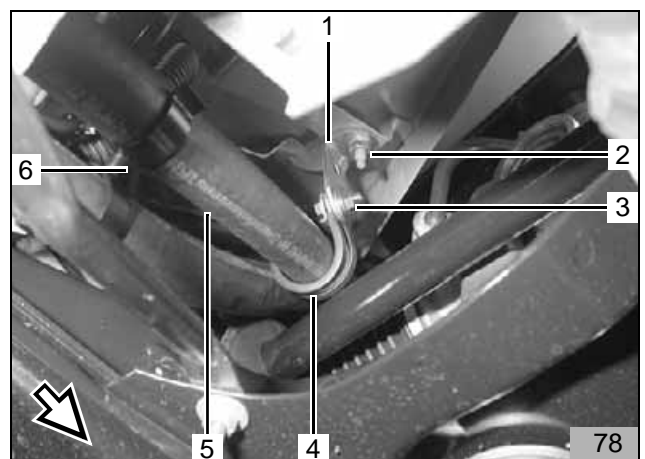

Thermo Top C

- Insert the enclosed spacer bracket (small) (79/2) between the 960 mm long water hose (79/4) and servo hose (79/3).
- Insert the spacer bracket (79/1) as shown in figure 80.

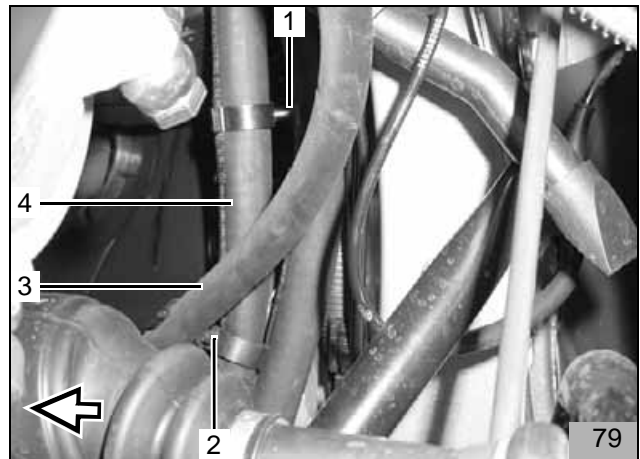

- Slide the black rubber profile (80/4) on the 960 mm long water hose (80/3).
- Slide the black rubber profile (80/1) on the 800mm long water hose (802).
- Align the black rubber profile (80/1, 4) on the brake amplifier.

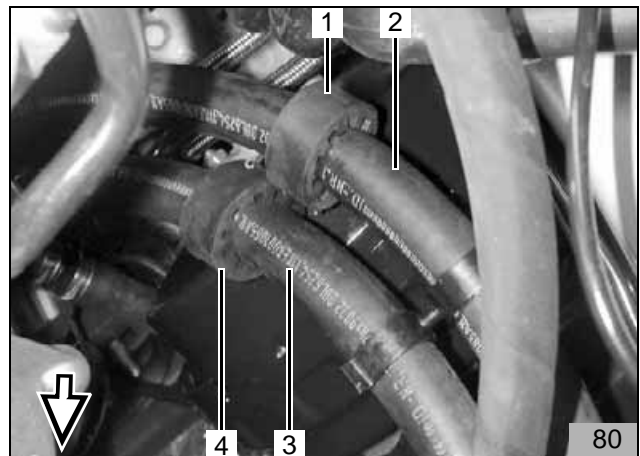

- Clamp the vehicle's own water hose (81/1,2) from the engine water outlet to the heat exchanger water inlet with hose clamps.
- Separate the original vehicle water hose (81/1,2) at the mark as shown in figure 82.
- Remove and dispose of the original vehicle hose section (81/2).

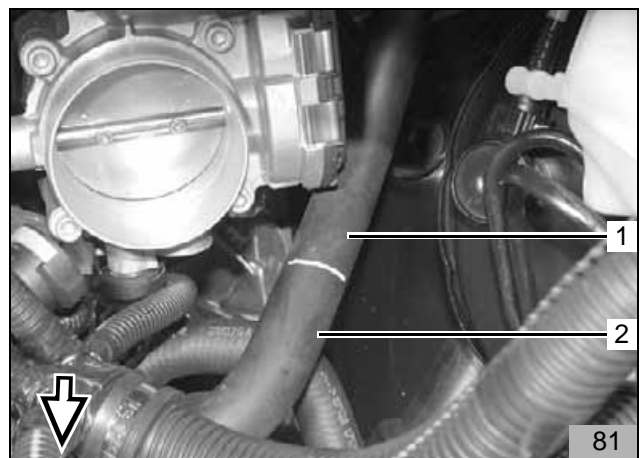

- Slide the 960 mm long water hose (82/2) onto the heater unit water outlet supports and fasten with original vehicle hose clamp (82/1).

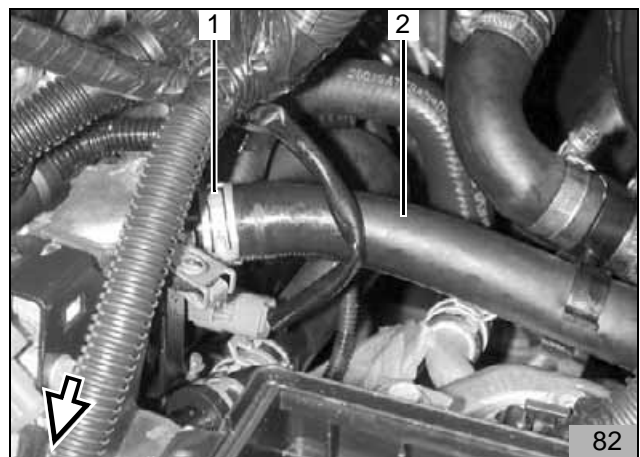

- Connect the 800 mm long water hose (83/1) and the 90° bend with the 20x20 connecting pipe and hose clamps as shown in figure 83.
- Connect the 90° bend (83/3) and the original vehicle hose section (83/4) to the heat exchanger water inlet with the 20x20 connecting pipe and hose clamps as shown in figure 83.
- Insert the spacer bracket (83/2) as shown in figure 83.

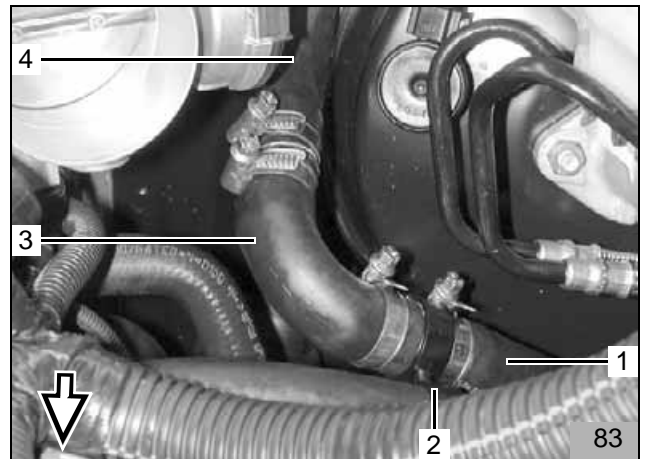

- Align the water hoses and position the black rubber profile (84/1,2) as shown in figure 85.

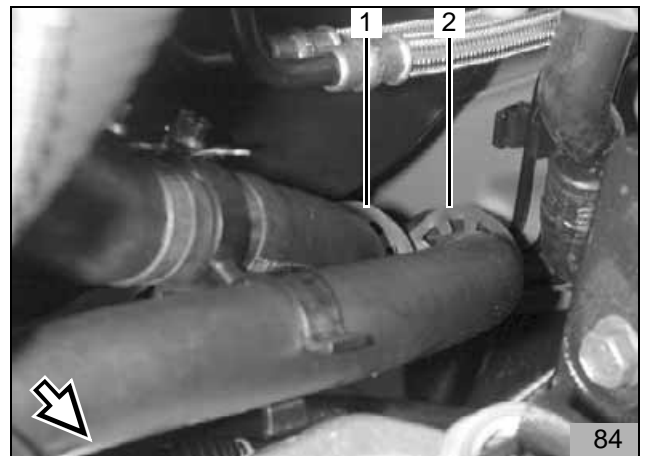

Final work

- Reassemble disassembled components in reverse order.
- Check that all hose lines, hose and tube clamps, and all electrical connections are securely fastened.
- Secure all loose lines using cable clips.
- Remove tools, such as vice-grip wrenches etc. from the engine compartment
- Connect the vehicle battery
- Spray heating unit components with anti-corrosion wax (Tectyl ML, Order No. 111329).
- Start the engine, bleed the water circuit according to the vehicle manufacturer's specifications, top up with cold water.
- Set the vehicle heater to "warm" and the blower to approx. 1/3
- Switch on the Webasto heating, see "Operating and Maintenance Instructions"

NOTE:

Fill out the installation confirmation on the back side of the EG type approval and give this to the customer.

Operating instructions for the end customer

NOTE:

Please cut out and hand over to the customer.

Before parking the vehicle (ignition), please make the following settings:

- Set the temperature (85/1,2,3,5) on both sides to "28° C".
- Set the air outlet (85/4) to the top to "on".

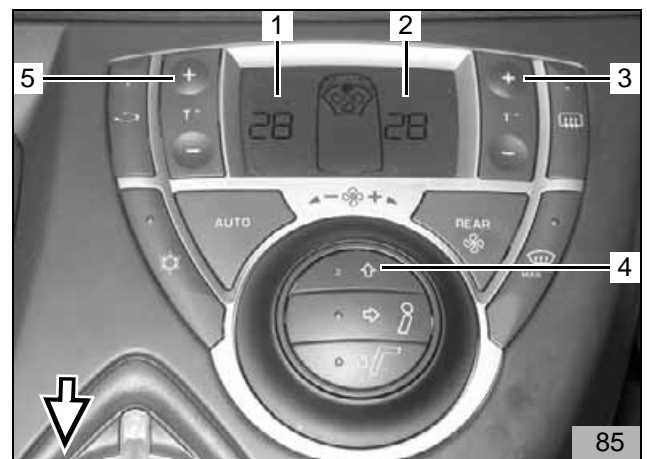



Tank mounting template C8

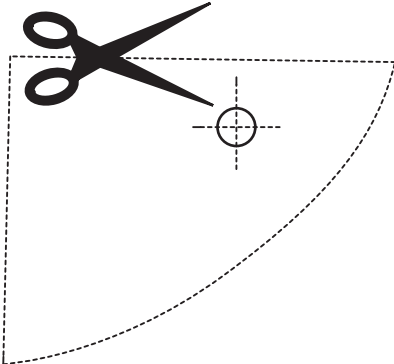

Tank extracting device C8

