

Supplementary heating *Thermo Top C* e1 00 0002

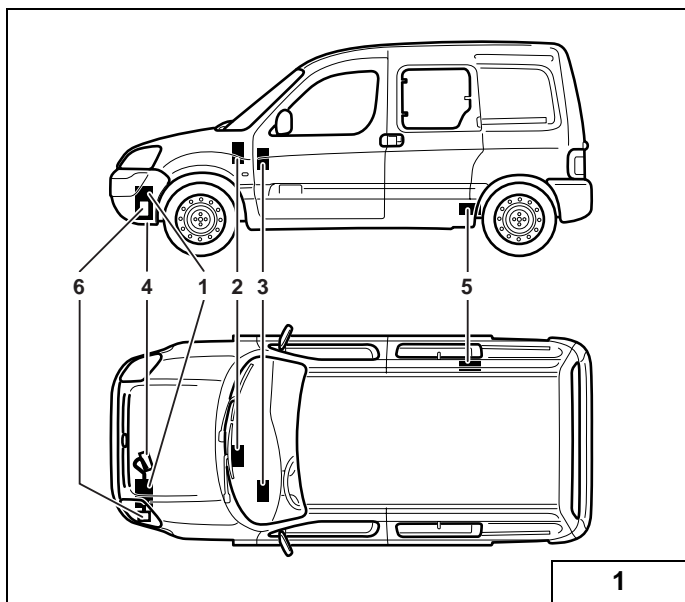

Installation instructions

Peugeot Partner

Citroen Berlingo

Gasoline and diesel

From model year 2003

Only for left-hand drive vehicles

Not for automatic transmission!

Legend

- 1 Heater Thermo Top C-D
- 2 Blade-Type Fuse Holder and Blower Relay
- 3 Time switch
- 4 Exhaust silencer
- 5 Metering pump
- 6 Combustion air intake silencer

Vehicle types, engine types, equipment variants and country specifications, which are not listed in these installation instructions, have not been tested.

Installation according to these installation instructions may, however, be possible.

Special tools

- Vice-grip wrench
- Torque spanner for 2.0 - 10 Nm

Table of Contents

Heater Unit / Installation Kit	2	Metering pump	9
Validity	2	Fuel take-off	10
Foreword	2	Preparing the water hoses	12
General Instructions	3	Water connection for all vehicles	14
Preliminary Work	3	Water Connection 1.6 l HDI	15
Heater Unit Installation Location	3	Water Connection 2.0 l HDI	16
Blade-Type Fuse Holder and Blower Relay	4	Water Connection 1.9 l Diesel	17
Time Switch and Summer / Winter Switch Option	6	Water Connection 1.4 and 1.6 l Gasoline	19
Preparing the installation location	7	Combustion air connection	20
Pre-assembling heater unit	7	Final work	21
Exhaust Connection	7	Operating instructions for the end customer	23
Installing the heater unit	8	Template	24
Fuel connection	9		

Thermo Top C _____ Peugeot Partner / Citroen Berlingo

Heater unit / Installation kit

Quantity	Name	Order No.
1	Water heater unit <i>Thermo Top C-B with scope of delivery</i>	906 04D
or		
1	Water heater unit <i>Thermo Top C-D with scope of delivery</i>	892 44D

Also required:

1	Installation kit for Peugeot Partner / Citroen Berlingo	1301565A
---	---	----------

Validity

Manufacturer	Model	Type	EG-BE No. / ABE
Peugeot	Partner	M49	e2*2001/116*0279*00
Peugeot	Partner	M49	L 083
Peugeot	Partner	M49	e2*2001/116*0282*00
Peugeot	Partner	G	e2*2001/116*0322*00
Citroen	Berlingo	M49	e2*2001/116*0276*00

Engine type	Engine model	Power in kW	Engine capacity in cm ³
KFW	Petrol	55	1360
NFU	Petrol	80	1587
9HX	Diesel	66	1560
WJY	Diesel	51	1867
RHY	Diesel	66	1997

L

Foreword

These installation instructions apply to Peugeot Partner and Citroen Berlingo vehicles with diesel and gasoline engines – re. validity, see title page – from model year 2003 and later, assuming technical modifications to the vehicle do not affect installation, any liability claims excluded.

Depending on the vehicle version and equipment, modifications may be necessary during installation with respect to these installation instructions.

However, the stipulations in the "installation instructions" and "operating and maintenance instructions" for the *Thermo Top C/E* are to be observed in any event.

The corresponding rules of technology and any information from the vehicle manufacturer should be observed during the installation work.

General instructions

- Cover unfinished body areas, such as bore holes, with corrosion protection
- Secure hoses, wires, and cable harnesses with cable clips and cover with protective hoses at friction locations
- Fit sharp edges with edge protection (split open plastic hose)

Preliminary work

Engine Compartment

CAUTION

Disconnect the battery.

Let off pressure in the cooling system.

- Remove the air filter housing
- Copy the factory number from the original type label to the duplicate type label
- Remove years that do not apply from the duplicate label
- Attach the duplicate label (type label) in the appropriate place

Vehicle Exterior

- Open the tank cap, ventilate the tank
- Close the tank cap again
- Remove the front bumper
- Remove front right wheel-house panel
- Remove the front left wheel-house panel
- Lower the tank (only for gasoline vehicles)

Vehicle Passenger Compartment

- Remove the lower dashboard panel on the passenger side

Heater unit installation location

- The heater unit (1) is installed on the front left between the bumper and the wheel house
- This is installed vertically, across the direction of travel

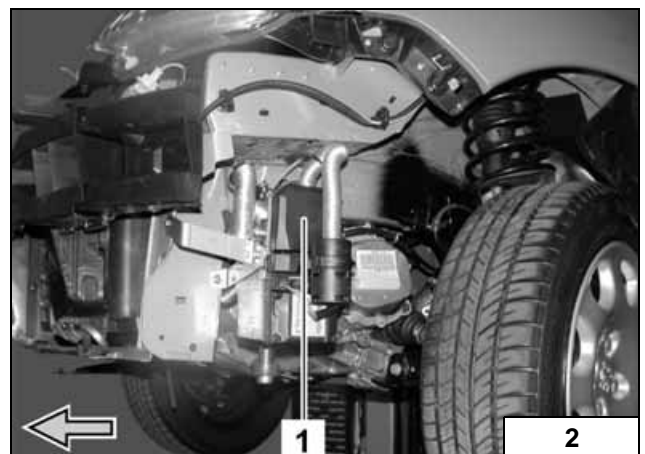

Blade-Type Fuse Holder and Blower Relay

- Hold the blade-type fuse holder retaining plate (1) and blower relay (2) on the cooling water reservoir and transfer the hole image
- Drill holes in the cooling water reservoir
- Fasten the blade-type fuse holder retaining plate (1) and blower relay (2) on the cooling water reservoir with the enclosed countersunk screws
- Insert the fuse holder (3) in the blade-type fuse holder retaining plate (1)
- Connect the ground wire to the battery negative terminal
- Connect the positive wire to the battery positive terminal
- Run the heater unit cable harness to the heater unit installation location

- Run the cable harnesses for the time switch (1) and blower control (2) through the original vehicle protective rubber sleeve (3) along the original vehicle cable harness into the passenger compartment

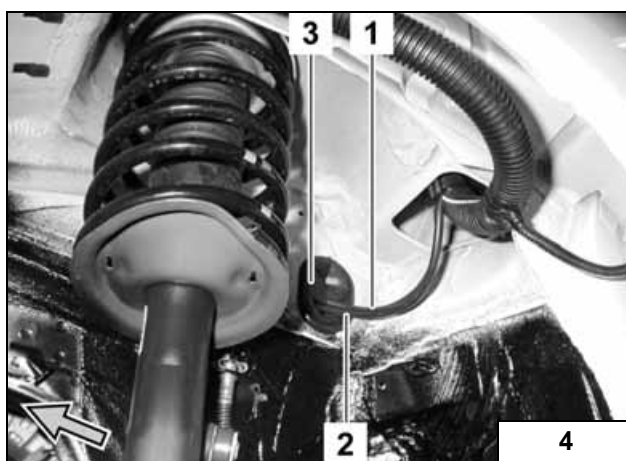

Blower control

The blower control is connected to the 2-pin connector from the blower motor under the glove compartment on the passenger side. Connect with enclosed flat connectors according to the circuit diagram.

Circuit diagram

- A1 Vehicle fuse holder
- A2 Blower motor
- F3 Blade-Type Fuse Holder
- K3 Blower relay
- X Splitting point

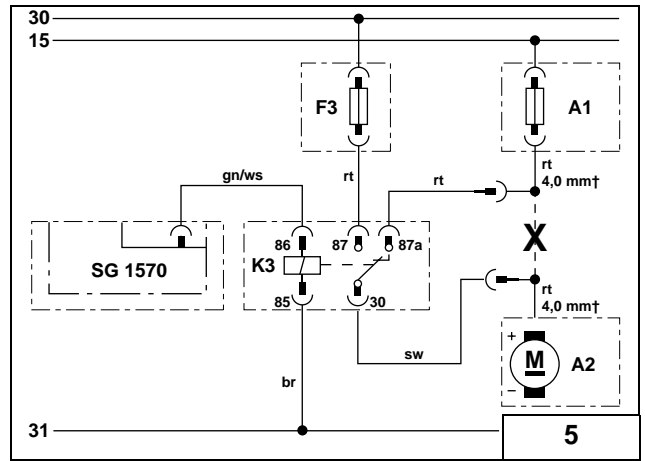

Cable Colors

- bl blue
- gn green
- rt red
- sw black
- ws white

- Run the blower cable harness to the blower motor and two pin connector (1) and cut off
- Separate the red wire, 4.0 mm² (2,3) about 50 mm before the 2-pin connector (1)
- Connect the red wire, 4.0 mm² (3) from the original vehicle cable harness with the red wire (4) from the K3/87a blower relay
- Connect the red wire2 (2) from the 2 pin connector (1) with the black wire (5) from the blower relay K3/30

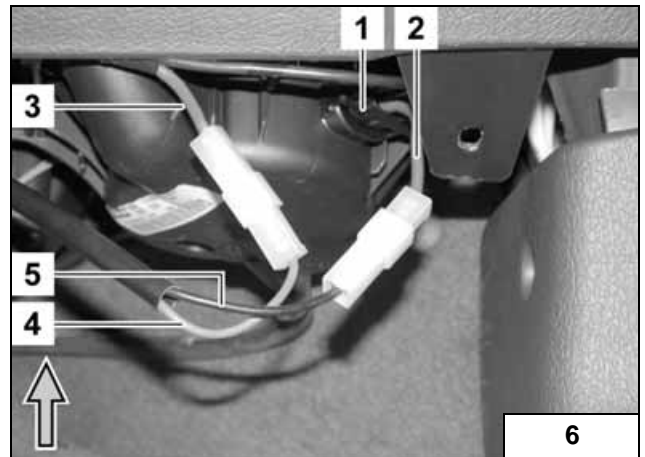

Time Switch and Summer / winter switch option

CAUTION

When installing the time switch, do not press on the LCD display

NOTE

The installation location shown for the time switch (1) and the summer / winter switch (2) is a recommendation. Before installing, please confirm the installation location with your customer.

- Attach the drilling template for the time switch at the suggested position.
- Drill two holes as on the template.
- Remove the template.
- Assemble the fastening lug with self-tapping screw

NOTE

Note the direction of the catch teeth (see Installation Instructions)!
Check for wear protection when placing the cable harness.

- Pull the time switch cable harness through the hole and attach connector to time switch
- Slide on the time switch (1)
- Transfer the hole image for the summer / winter switch (2) to the desired position and drill the Ø 12 mm hole
- Guide the nut and tooth lock washer over both wires
- Run the brown and violet wires through the hole and connect to the switch as shown (lower contacts)
- Fasten the summer / winter switch (2) with the tooth lock washer and nut

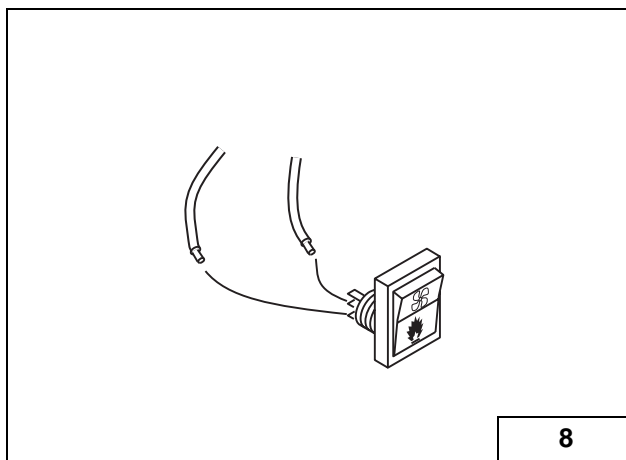
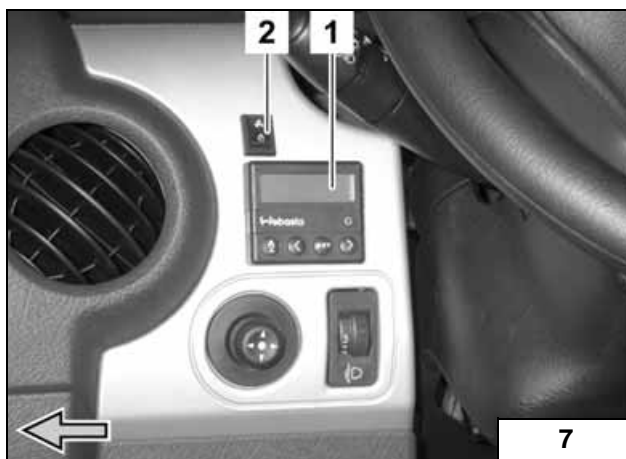

Preparing the Installation Location

- Cut off the 100 mm edge protection to 80 mm and insert at position 1
- Insert the 200 mm edge protection at position 2



Pre-assemble the Heater Unit

NOTE

Use Ejot screw bolts.
Tightening torque 10 Nm!

- Fasten the strut (1) with Ejot screw bolts to the heater unit (tightening torque 10 Nm)
- Fasten the fastening strap (2) with Ejot screw bolts to the heater unit (tightening torque 10 Nm)
- Tighten the exhaust silencer (3) to the fastening strap (2) with the M6x20 bolt and M6 flanged nut

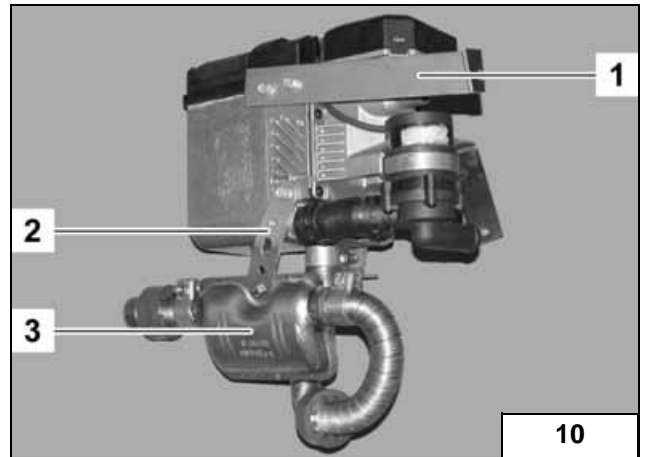

Exhaust connection

- Disconnect exhaust pipe according to illustration

- 1 = Heater unit silencer exhaust pipe
- 2 = Section (is not required)
- 3 = Exhaust end section

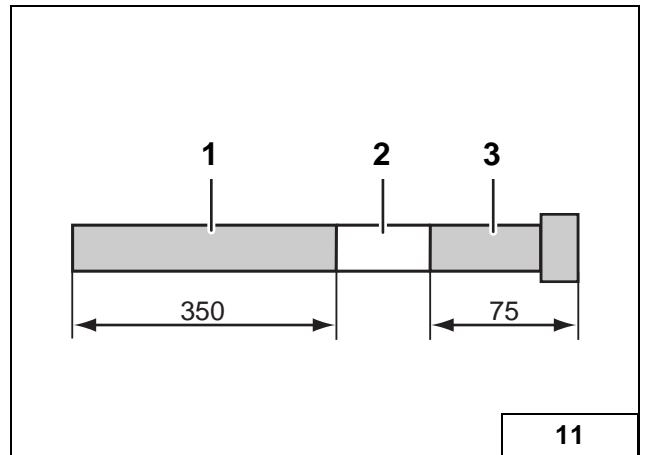

- Fasten the struts (1 and 2) with Ejot screw bolts to the heater unit (tightening torque 10 Nm).

- Shape the exhaust pipe (3) as shown in the figure and slide the red rubber profile (4) onto the exhaust line (3)
- Slide the exhaust pipe (3) on the heater unit and on the silencer (5) and tighten with the hose clamp (2)
- Slide the exhaust pipe end section (6) on the silencer (5) and fasten with the hose clamp
- Slide the red rubber profile (7) on the exhaust pipe end section (6)

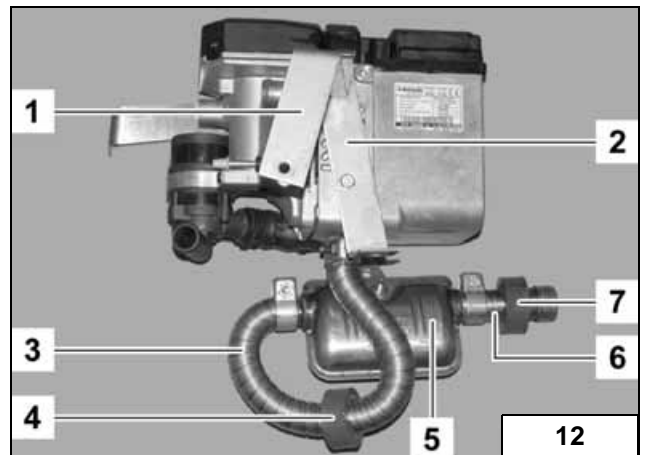

Installing the heater unit

- Fasten the preassembled heater unit with the M6x20 bolt (1), body washer A7, 4 and MG flanged nut according to the figure

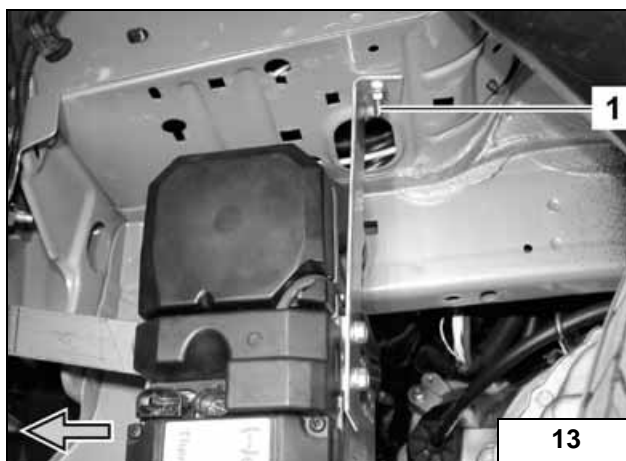

- Fasten the preassembled heater unit with the M6x20 bolt (1), body washer A7, 4 and MG flanged nut according to the figure
- Copy the bore hole (3) from the strut (2) onto the crossarm and drill Ø 7.5 mm bore hole

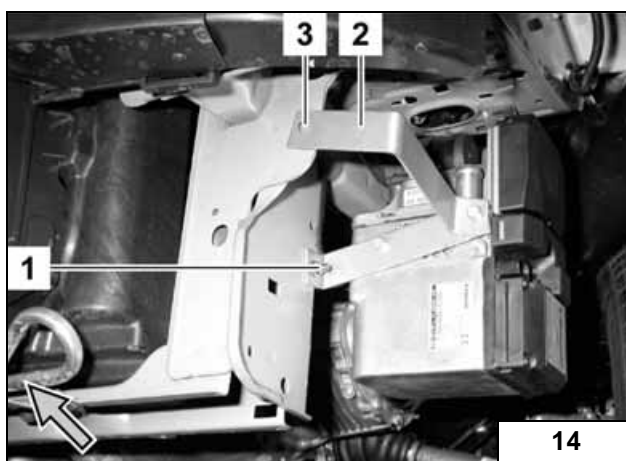

NOTE

Insert 5 mm spacer sleeve between the crossarm and the strut (2).

- Fasten the preassembled heater unit with the M6x20 bolt (1), 5 mm spacer sleeve, body washer A7, 4 and MG flanged nut according to the figure

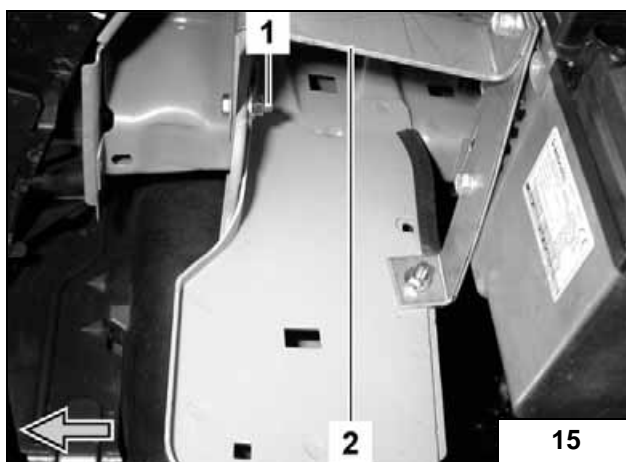

- Insert the cable harness (1) on the heater unit and tighten on the strut with the hose clamp (2)

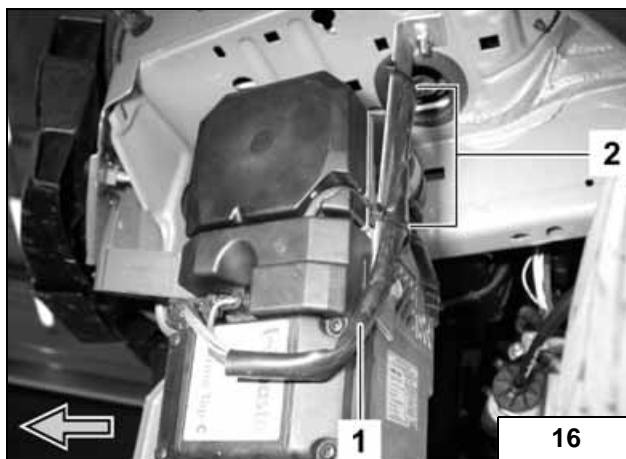

Fuel connection

- Fasten the Mecanyl fuel line (1) to the heater unit with a hose section (2) and Ø 10 mm hose clamps
- Run the Mecanyl fuel pipe (1) from the heater unit through the existing feed-through in the engine compartment and along the original vehicle lines to the engine compartment rear bulk
- Route the mecanyl fuel line (1) together with the metering pump cable harness behind the original vehicle cable harness to the right side of the vehicle and then along the original vehicle fuel lines to the underbody

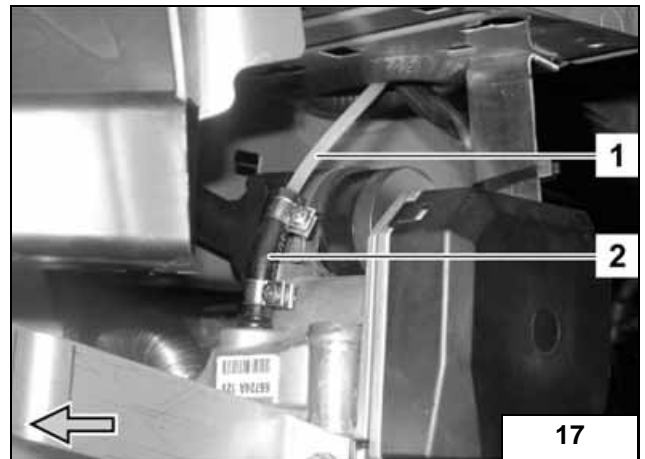

Metering pump

- Fasten the angle bracket (1) on the original vehicle bolt (2) according to the figure

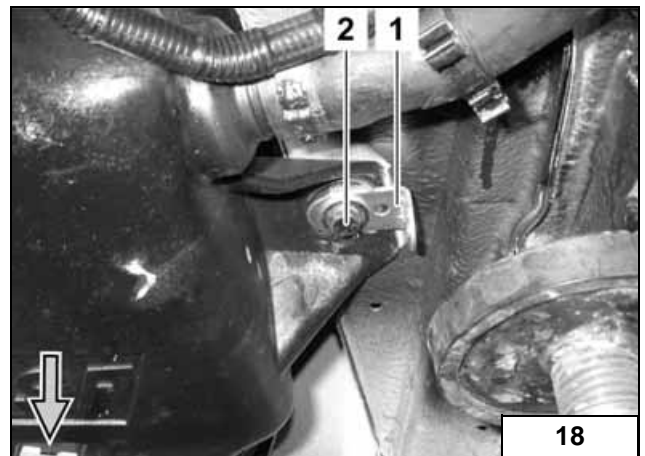

- Fasten the metering pump (1) with rubber tube clamp (2) and M6 flanged nut to the silentblock (3)
- Fasten the pre-assembled metering pump (1) to the angled bracket (4) with the flanged nut
- Run the cable harness for the metering pump (7) and the Mecanyl fuel pipe (5) along the original vehicle fuel lines on the underbody to the installation location of the metering pump
- Cut the Mecanyl fuel line (5) on the metering pump (1) into sections and use the hose section (6) and the Ø10 mm hose clamps to connect to the pressure end of the metering pump (side with the connector) as shown in the figure
- Cut the metering pump cable harness (7) on the metering pump (1) into sections, put on the protective rubber sleeve, crimp on the flat connector, complete the connector housing, and put the metering pump cable harness (7) on the metering pump (1) as shown in the figure.

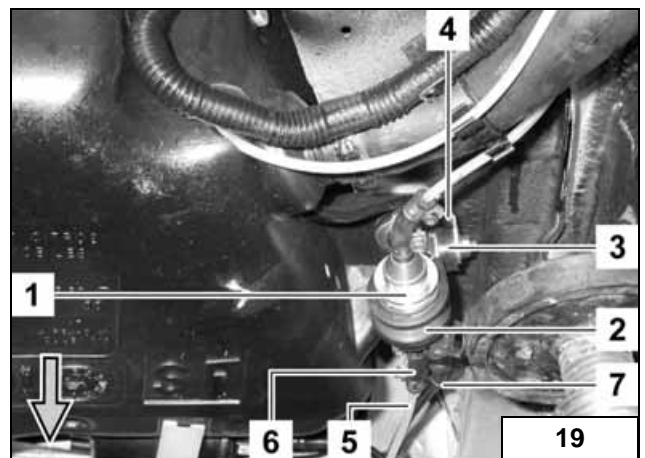

Fuel take-off

Vehicles with gasoline engines only

The fuel is extracted with the fuel extractor from the ventilation line.

- Bend and cut the tank extracting device according to the enclosed template
- Bend the end of the tank extracting device as shown in the figure and cut to size



- Cut out the ventilation lines (1 and 2) at the marking



- Pull the ventilation line (1) from the tank supports and slide onto the tank extracting device (2) as shown in the figure

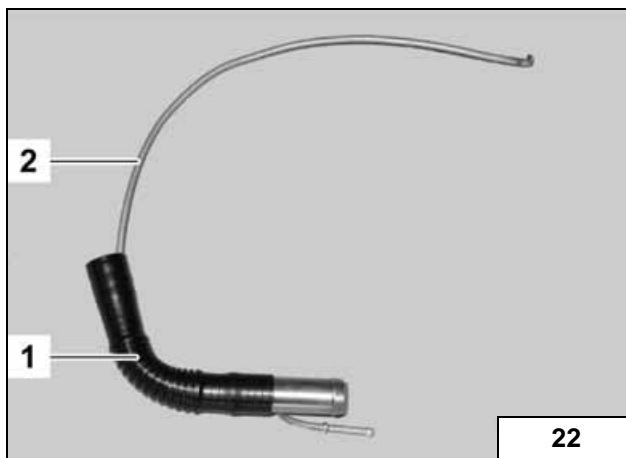

- Insert the pre-assembled tank extracting device (3) in the side of the tank. Position the tank extracting device (3) so that the unbent end lies on the inside of the tank floor
- Slide the ventilation line (1) on the tank supports and align as shown in the figure
- Slide the ventilation line (2) on the tank extracting device (3)

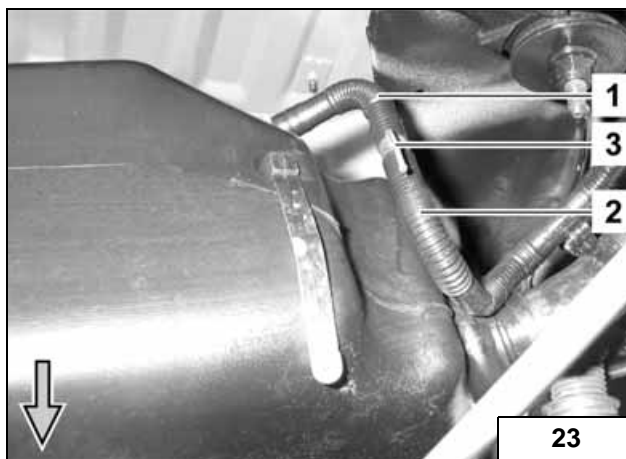

- Fasten the rest of the Mecanyl fuel line (1) to the tank extracting device with the hose section (2) and \varnothing 10 mm hose clamps as shown in the figure
- Run the Mecanyl fuel pipe (1) through the original vehicle cable clip (3) to the metering pump installation location
- Install the tank according to the manufacturer's instructions

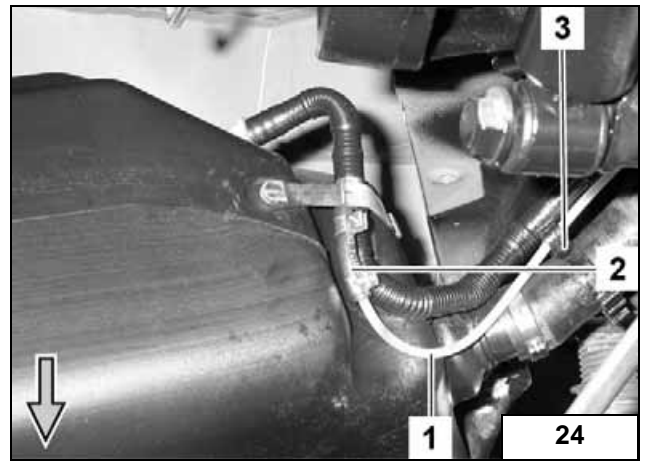

- Cut the Mecanyl fuel line (2) on the metering pump (1) into sections and use the hose section (3) and the \varnothing 10 mm hose clamps to connect to the pressure end of the metering pump (side without connector) as shown in the figure.
- Insert the Mecanyl fuel pipe (2) in the original vehicle cable clip (4)

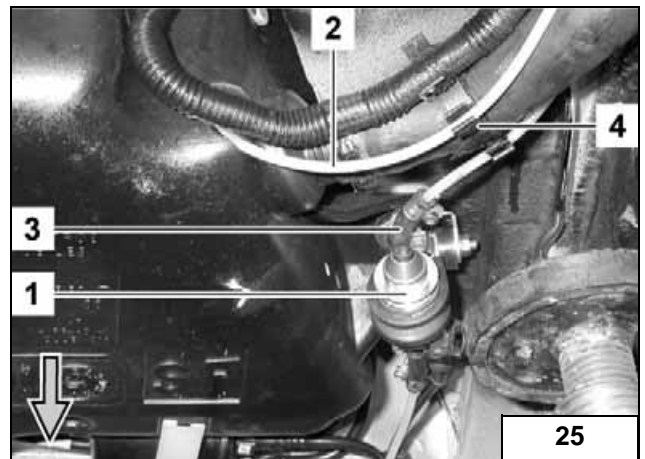

Only vehicles with diesel engines

The fuel is extracted with the fuel extractor from the leading fuel line.

- Disconnect leading fuel line (1 and 2) according to the illustration
- Insert the fuel extractor (3) in the line ends and fasten with \varnothing 10 mm hose clips
- Fasten the rest of the Mecanyl fuel line (4) to the tank extracting device with the hose section (5) and \varnothing 10 mm hose clamps as shown in the figure and run this to the metering pump

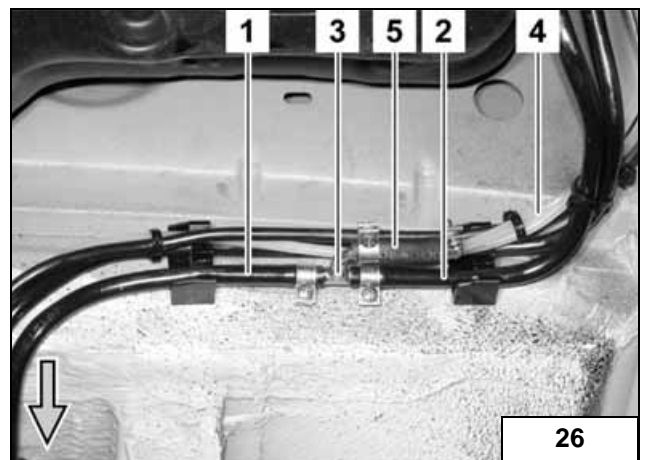

- Cut the Mecanyl fuel line (1) on the metering pump (3) into sections and use the hose section (2) and the \varnothing 10 mm hose clamps to connect to the suction end of the metering pump (side without connector) as shown in the figure
- Fasten the Mecanyl fuel line (1) with cable clips

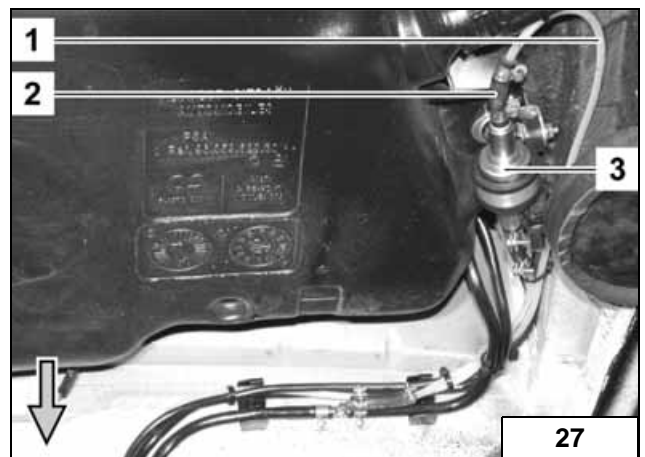

Preparing the water hoses

- Cut water hoses into sections as shown in the figure
- Slide the enclosed 1000 mm heat protection hoses onto hose 2 and 3

Only for vehicles 1.6 I HDI engines

- Hose 1:**
90° bend (from the heater unit input to hose 2)
- Hose 2:**
600 mm + 180° bend (from hose 1 to the original vehicle engine outlet hose).
- Hose 3:**
540 mm + 90° bend (from the heater unit outlet to the electrical heater hose)
- Section a:**
Is not required

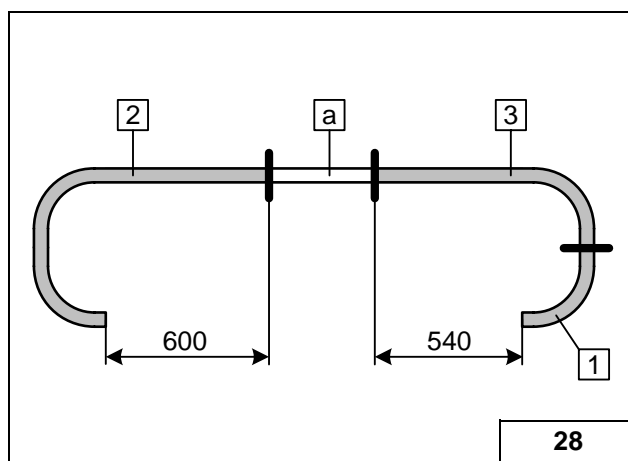

Only for vehicles 2.0 I HDI engines

- Hose 1:**
90° bend (from the heater unit input to hose 2)
- Hose 2:**
740 mm + 180° bend (from hose 1 to the original vehicle engine outlet hose).
- Hose 3:**
660 mm + 90° bend (from the heater unit outlet to the electrical heater hose)
- Section a:**
Is not required

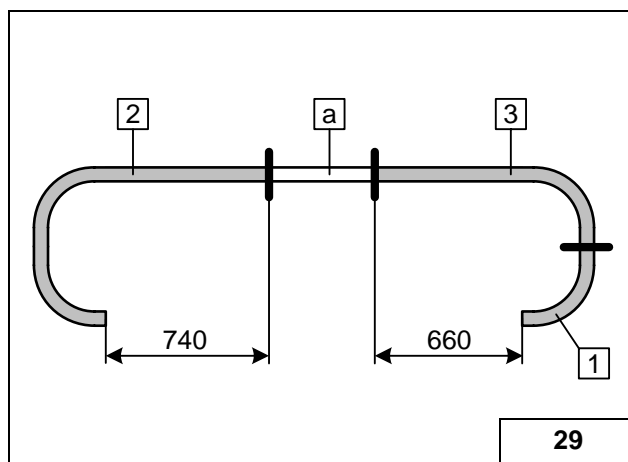

Only for vehicles 1.9 I diesel engines

- Hose 1:**
90° bend (from the heater unit input to hose 2)
- Hose 2:**
980 mm + 180° bend (from hose 1 to the enclosed 180° bend).
- Hose 3:**
890 mm + 90° bend (from the heater unit outlet to the original vehicle heat exchanger inlet hose).
- Section a:**
Is not required

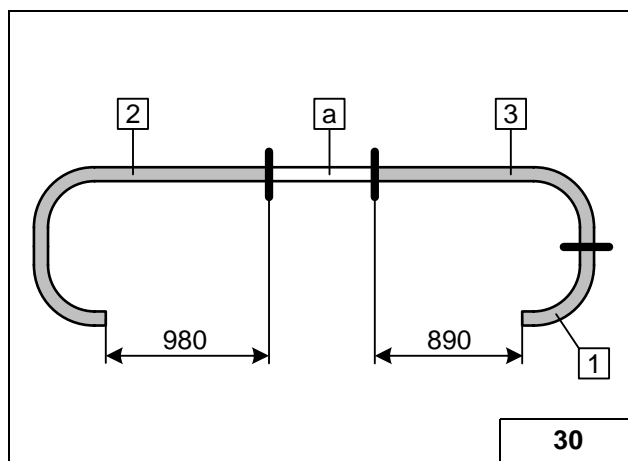

Only for vehicles 1.4 I and 1.6 I gasoline engines

Hose 1:

90° bend (from the heater unit input to hose 2)

Hose 2:

780 mm + 180° bend (from hose 1 to the enclosed 180° bend)

Hose 3:

700 mm + 90° bend (from the heater unit outlet to the original vehicle heat exchanger inlet hose).

Section a:

Is not required

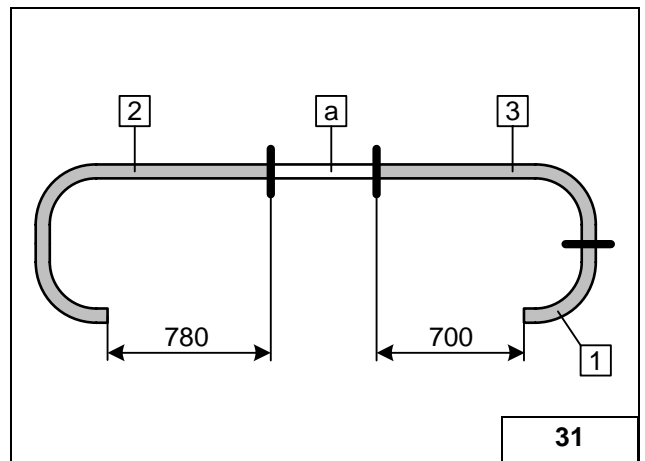

Water connection

For all vehicles

- Place hose 3 (1) with 90° bend on the heater unit outlet, align as shown in the figure and tighten with the hose clamp



- Place hose 1 (1) with 90° bend on the heater unit inlet, align as shown in the figure and tighten with the hose clamp
- Insert connecting pipe (2) 20x20 in the 90° bend from hose (1) and fasten this with hose clamps

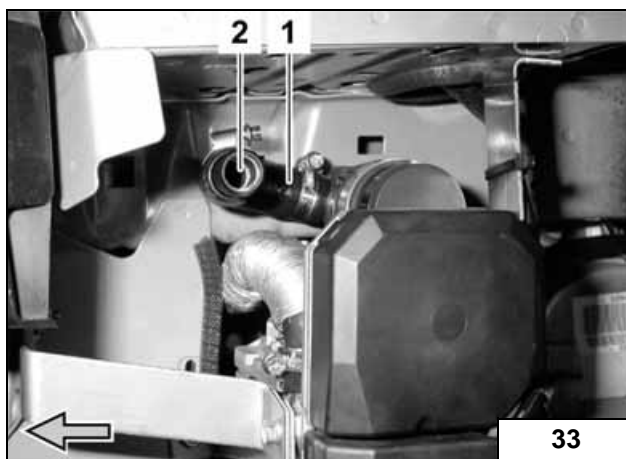

- Place hose 2 (1) with 180° bend on the connecting pipe (2), align as shown in the figure and tighten with the hose clamp

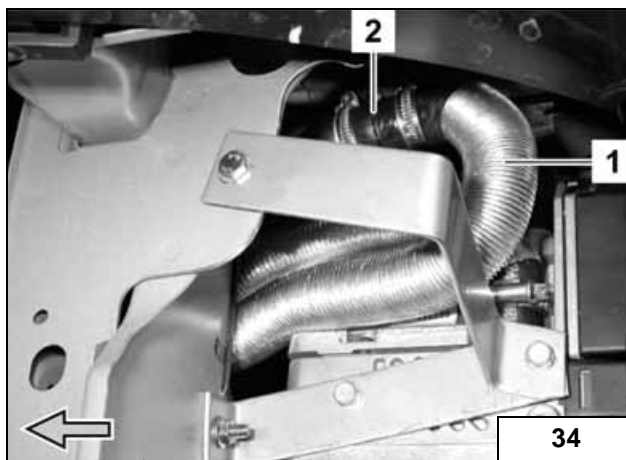

- Place the straight ends of hose 3 (1) and hose 2 (2) under the frame side rail in the engine compartment as shown in the figure

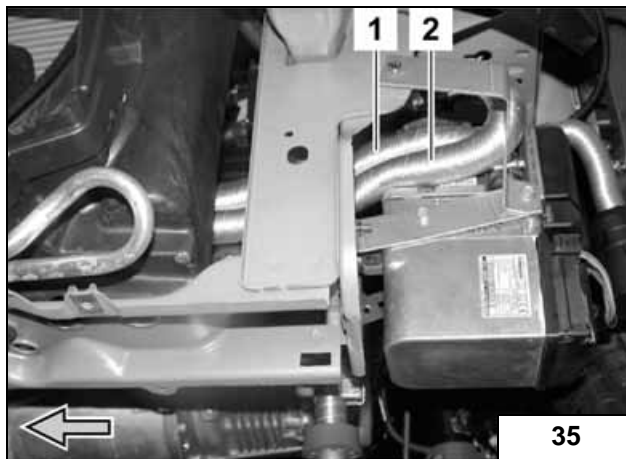

Only for vehicles 1.6 I HDI engines

- Disconnect the original vehicle engine outlet hose to heat exchanger inlet (2) at the engine outlet supports. The original vehicle spring band clamp (1) will be used again.

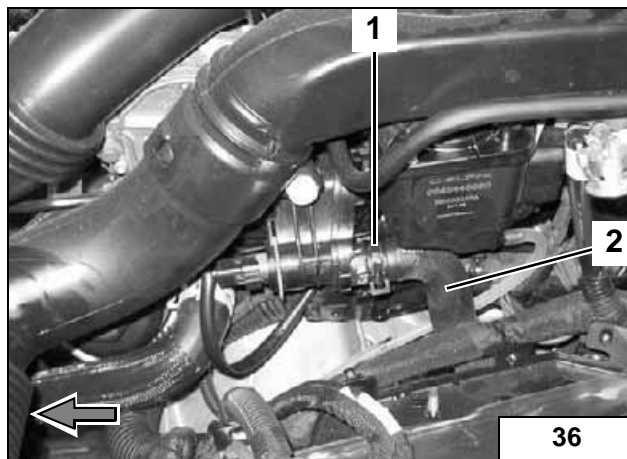

- Slide enclosed 180° bend (1) on the engine outlet supports and fasten with the hose clamp as shown in the figure
- Connect hose 2 (2) from the heater unit inlet and the 180° bend (1) from the engine outlet with the connecting pipe 18x20mm and hose clamps as shown in the figure

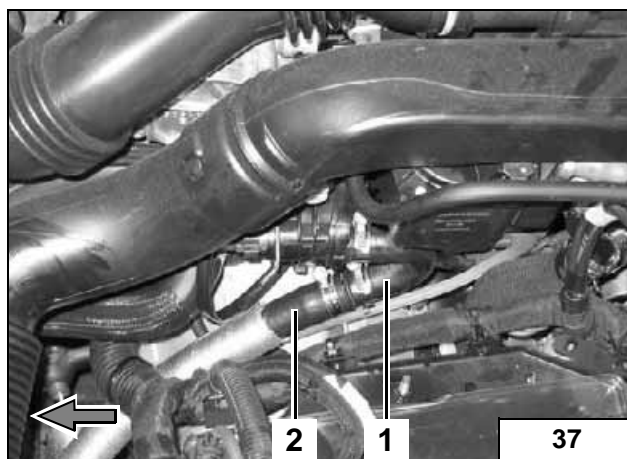

- Connect hose 3 (2) from the heater unit outlet and original vehicle hose (1) for the heat exchange inlet with connecting pipe 18x20 and hose clamps as well as the original vehicle spring band clamp as shown in the figure
- Fasten the hose 3 (2) and original vehicle hose (1) with cable ties

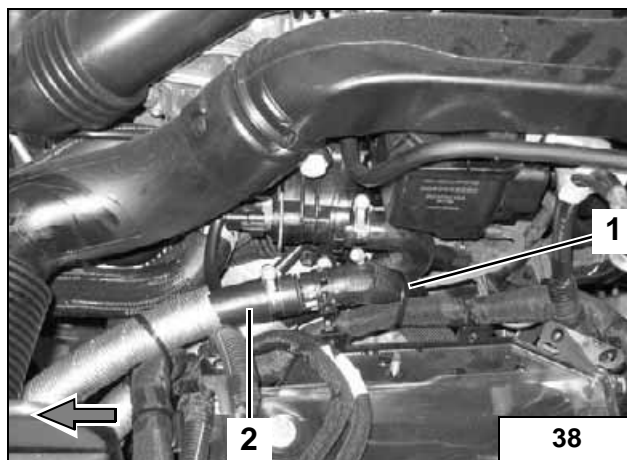

Only for vehicles 2.0 I HDI engines

- Bend the fastening strap with holes (1) 90° according to the figure and drill open to Ø 8.5 mm

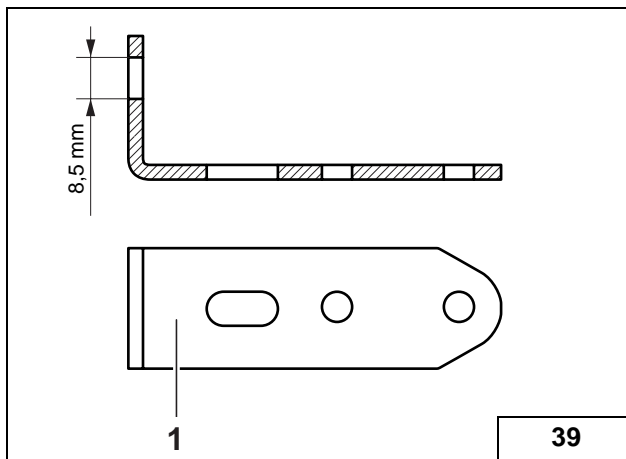

- Fasten the fastening strap (1) on gear with the original vehicle bolt (2)

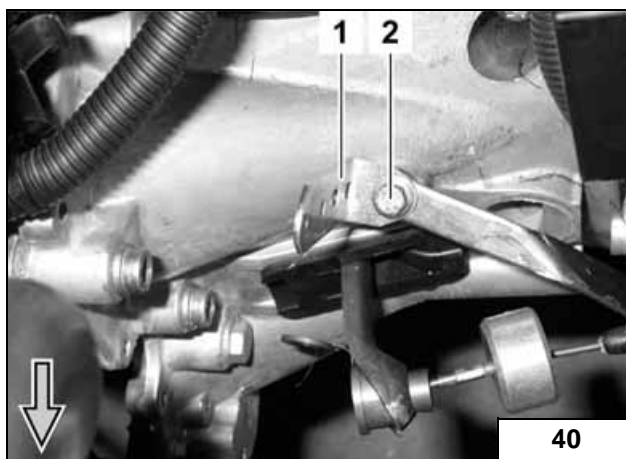

- Remove the protective hose (1) on the original vehicle engine outlet hose to the electrical auxiliary heater inlet.

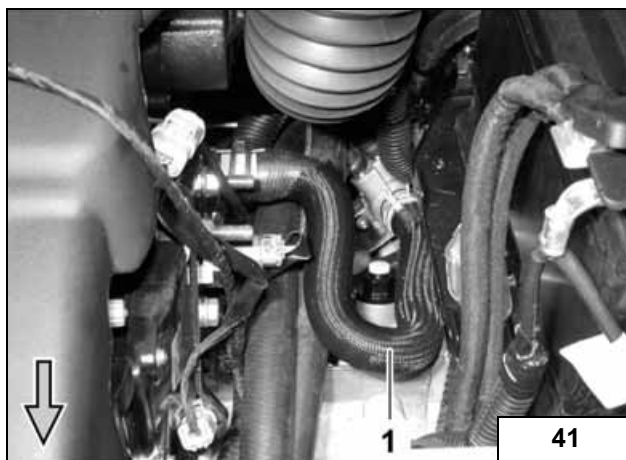

- Clamp out the original vehicle hose for the engine outlet (1, 2 and 3) to the electrical auxiliary heater inlet with pinch clamps and separate at the mark
- Dispose of the original vehicle hose (3)

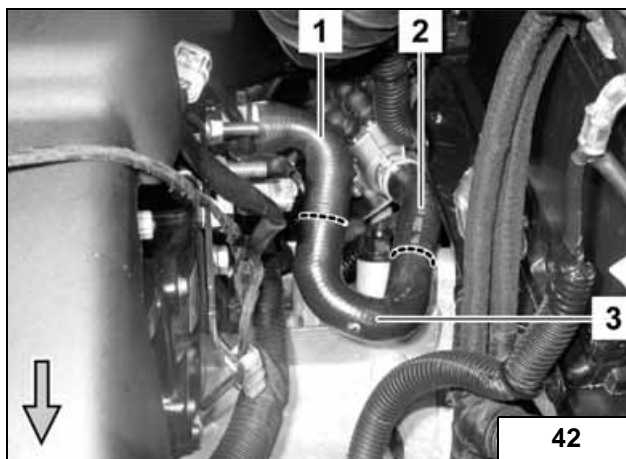

- Connect hose 3 (3) from the heater unit outlet and original vehicle hose (1) for the electrical auxiliary heater inlet with connecting pipe 18x20 and hose clamps as shown in the figure
- Connect hose 2 (2) from the heater unit inlet and original vehicle hose (4) for the engine outlet with connecting pipe 18x20 and hose clamps as shown in the figure

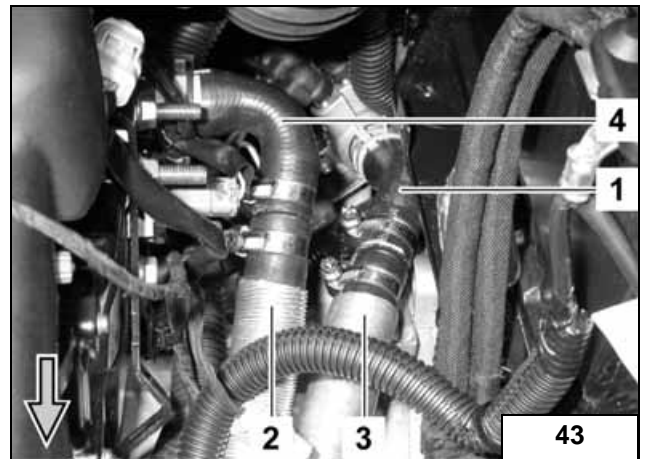

- Fasten the hose 2 (2) and hose 3 (3) with the rubberised tube clamps (4 and 5), M6x20 bolts and M6 flanged nut to the fastening strap according to the figure
- Arrange hose 2 (2) and hose 3 (3) and secure with cable clips

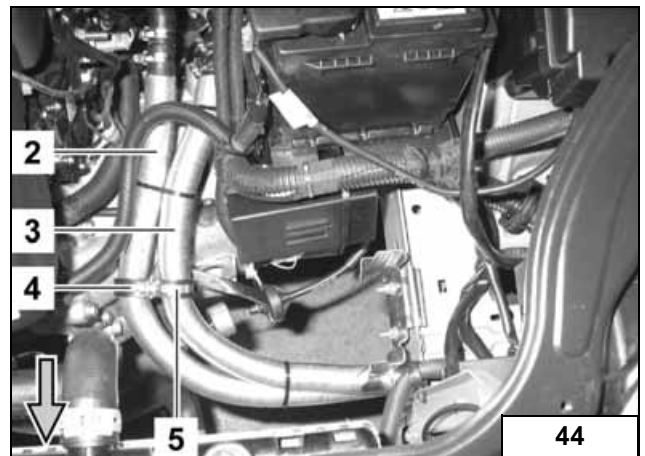

Only for vehicles 1.9 I diesel engines

- Bend the fastening strap with holes (1) 90° according to the figure and drill open to Ø 8.5 mm

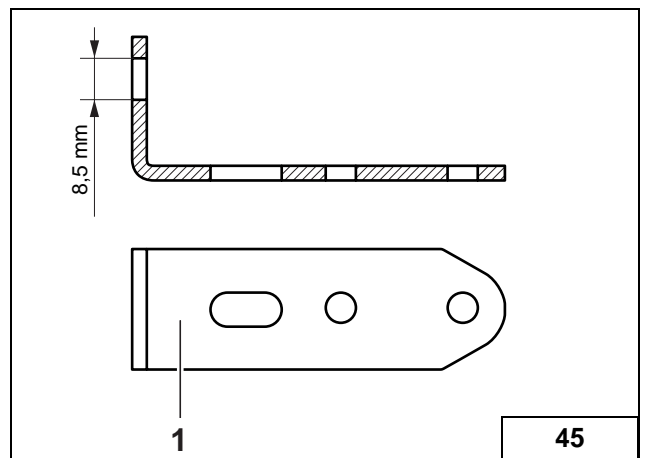

- Fasten the fastening strap (1) on gear with the original vehicle bolt (2)

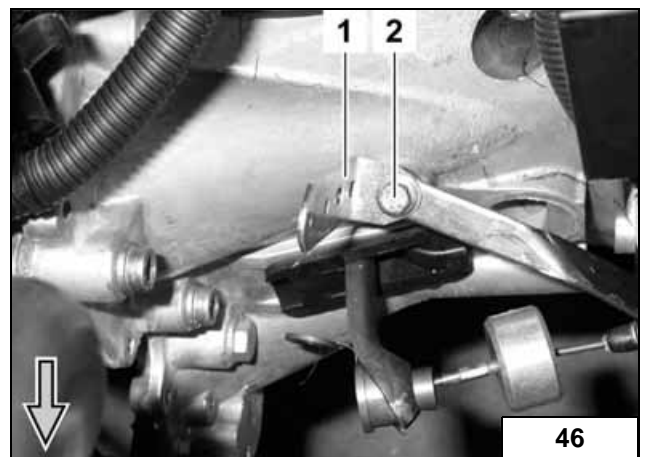

- Clamp off the original vehicle hose for the engine outlet (1 and 2) to the heat exchanger inlet with pinch clamps and separate at the mark

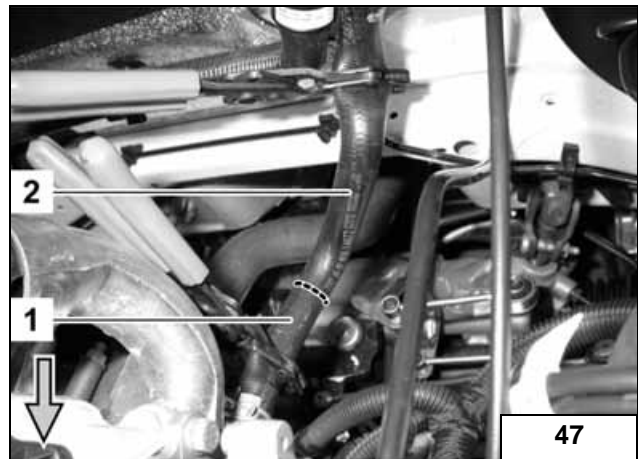

- Connect enclosed 180° bend (4) and the original vehicle hose for the engine outlet (1) with the 18x18 connecting pipe and hose clamps as shown in the figure
- Connect hose 2 (2) from the heater unit inlet and the 180° bend (4) from the engine outlet with the connecting pipe 18x20mm and hose clamps as shown in the figure
- Connect hose 3 (3) from the heater unit outlet and original vehicle hose (5) for the heat exchange inlet with connecting pipe 18x20 and hose clamps as shown in the figure
- Insert the enclosed spacer bracket (6) between the hose 2 (2) and hose 3 (3)

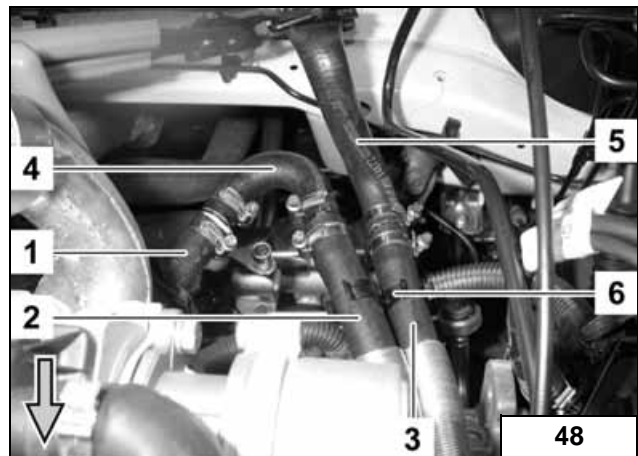

- Fasten the hose 2 (2) and hose 3 (3) with the rubberised tube clamps (4 and 5), M6x20 bolts and M6 flanged nut to the fastening strap according to the figure

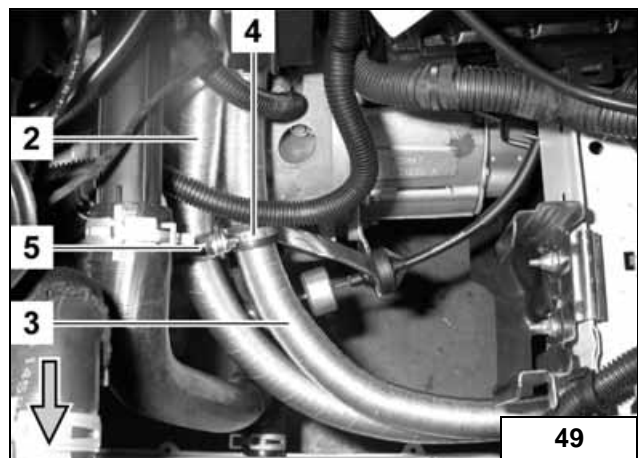

- Arrange hose 2 (2) and hose 3 (3) and secure with cable clips

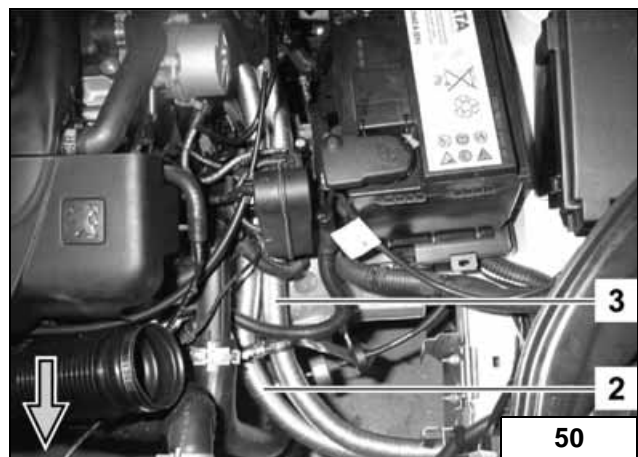

Only for vehicles 1.4 I and 1.6 I gasoline engines

- Bend the fastening strap with holes (1) 90° according to the figure and drill open to Ø 8.5 mm

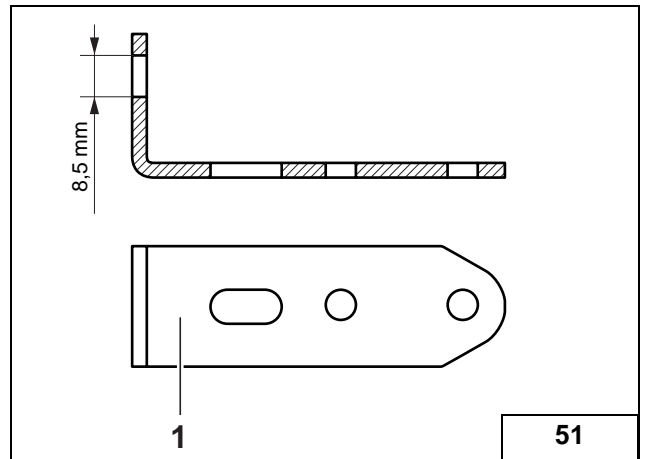

- Pull out the original vehicle cable clip from position 1 and insert this at position 2
- Fasten the fastening strap (3) on the battery support with M6 x 20 bolt (1), body washer A7.4 and MG flanged nut



- Clamp off the original vehicle hose for the engine outlet (1 and 2) to the heat exchanger inlet with pinch clamps and separate at the mark



- Connect enclosed 180° bend (4) and the original vehicle hose for the engine outlet (1) with the 18x18 connecting pipe and hose clamps as shown in the figure
- Connect hose 2 (2) from the heater unit inlet and the 180° bend (4) from the engine outlet with the connecting pipe 18x20mm and hose clamps as shown in the figure
- Connect hose 3 (3) from the heater unit outlet and original vehicle hose (5) for the heat exchange inlet with connecting pipe 18x20 and hose clamps as shown in the figure
- Insert the enclosed spacer bracket (6) between the hose 2 (2) and hose 3 (3)

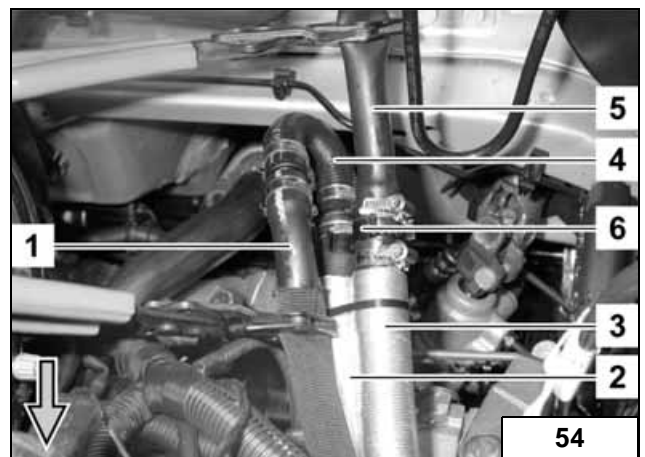

- Fasten the hose 2 (2) and hose 3 (3) with the rubberised tube clamps (4 and 5), M6x20 bolts and M6 flanged nut to the fastening strap (1) according to the figure

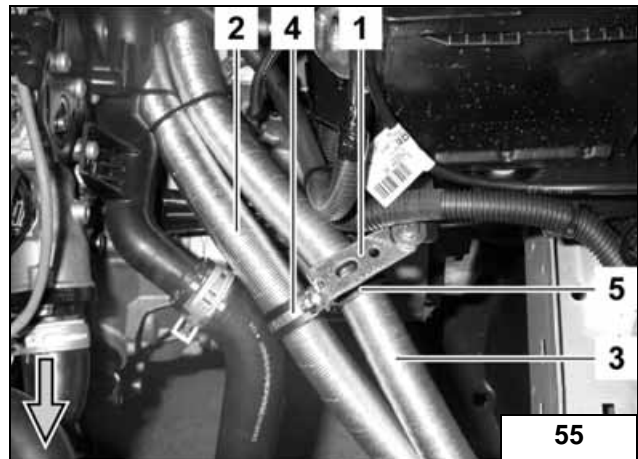

- Arrange hose 2 (2) and hose 3 (3) and secure with cable clips



Combustion Air Connection

- Slide the combustion air intake line (1) on the heater unit and tighten with the hose clamp as shown in the figure
- Shape the combustion air intake line (1) and fasten to the strut with cable ties

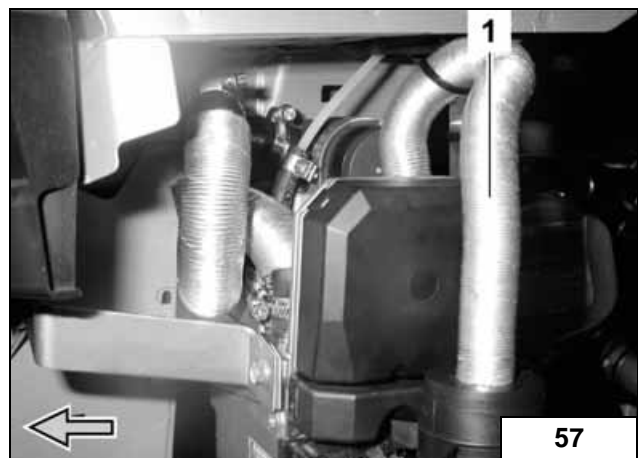

- Turn the intake silencer (2) in to the stop in the combustion air intake line (1)
- Punch out the perforation in the heater unit cover, insert the retaining clip (3)
- Insert the intake silencer (2) in the retaining clip (3)

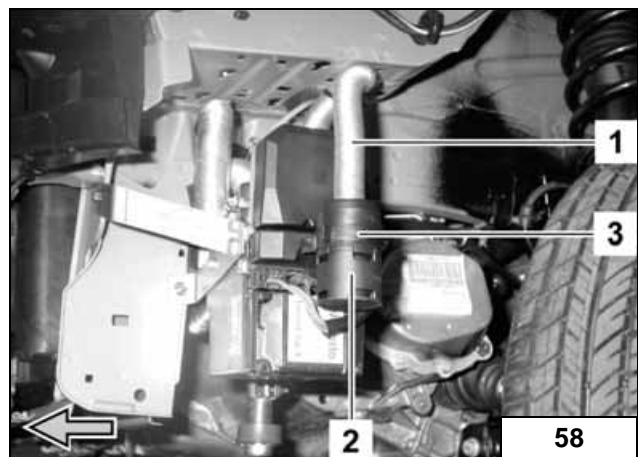

Final work

- Align the red rubber profile (1) on the lower water hose and position as shown in the figure

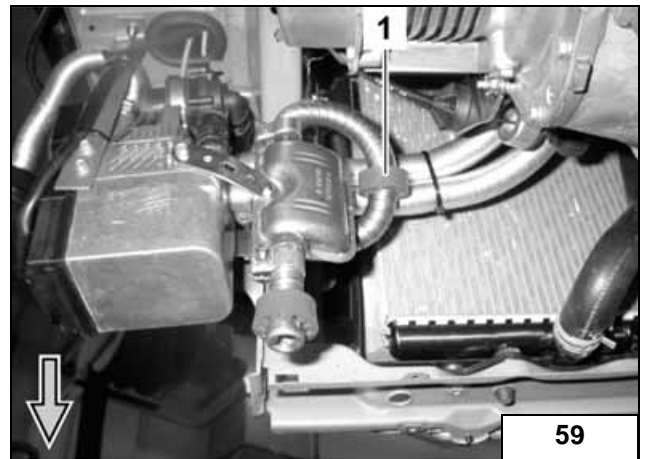

- Cut out the side panelling on the gear cover at the markings as shown in the figure and assemble with the left wheel-house panel

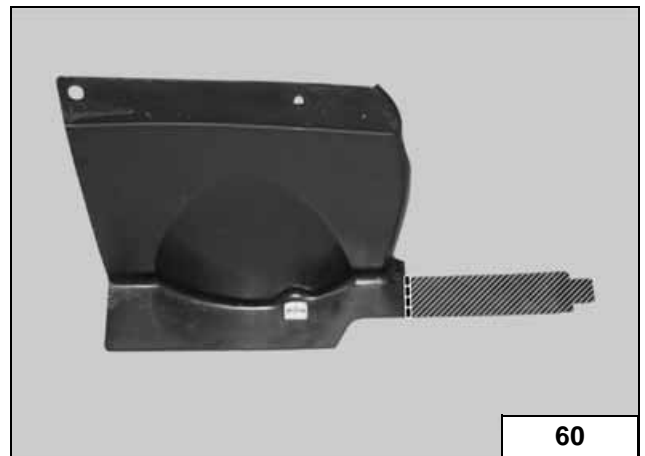

- Cut out the underride protection (when used) near the exhaust outlet and assemble as shown in the figure

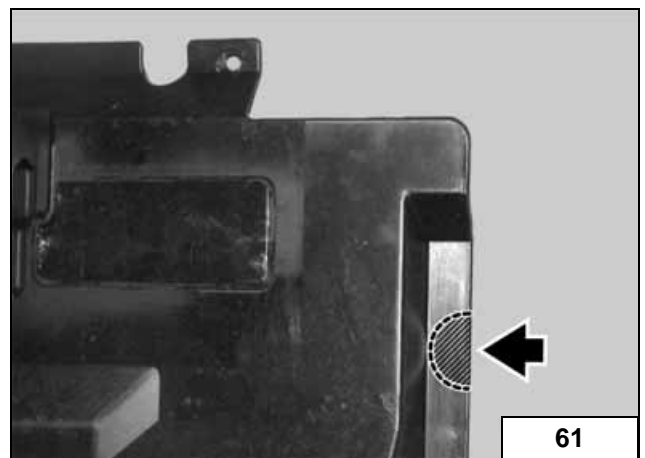

- Align the red rubber profile (1) between the underride protection and the wheel-house panel and position as shown in the figure

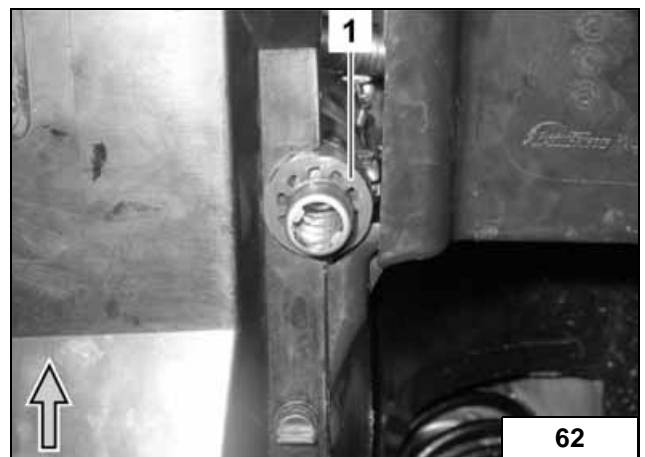

WARNING!



Reassemble disassembled components in reverse order.

Check that all hose lines, hose, spring band clamps and universal clips, and all electrical connections are securely fastened.

Secure all loose cables using cable clips.

Only use manufacturer-approved coolant.

Spray heating unit components with anti-corrosion wax (Tectyl 100K, Order No. 111329).

- Connect battery
- Fill and bleed the coolant circuit according to the vehicle manufacturer's specifications
- Set the time switch
- Make settings according to "Operating instructions for the end customer"
- Check that the auxiliary heating operates properly, see operating instructions / installation instructions
- Attach the "Switch off auxiliary heating before re-fuelling" sticker onto the left side of the B-pillar



Webasto

Feel the drive

Operating instructions for the end customer

Please remove page and add to the vehicle operating instructions.

Before parking the vehicle, make the following settings:

- Switch to "Defrost" (1)
- Temperature to "max." (2)
- Blower to setting "1" (3)

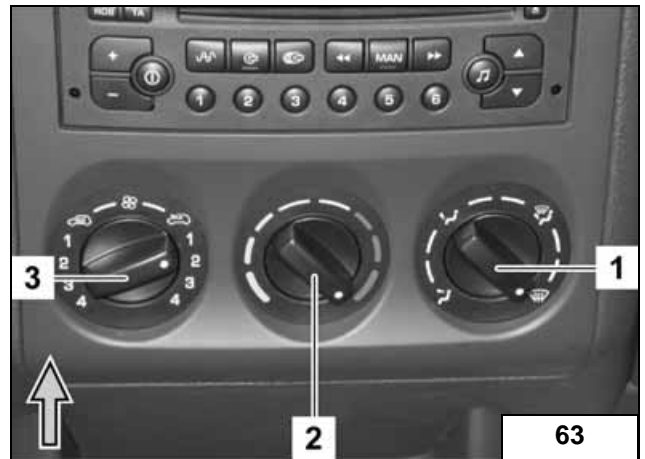

Template

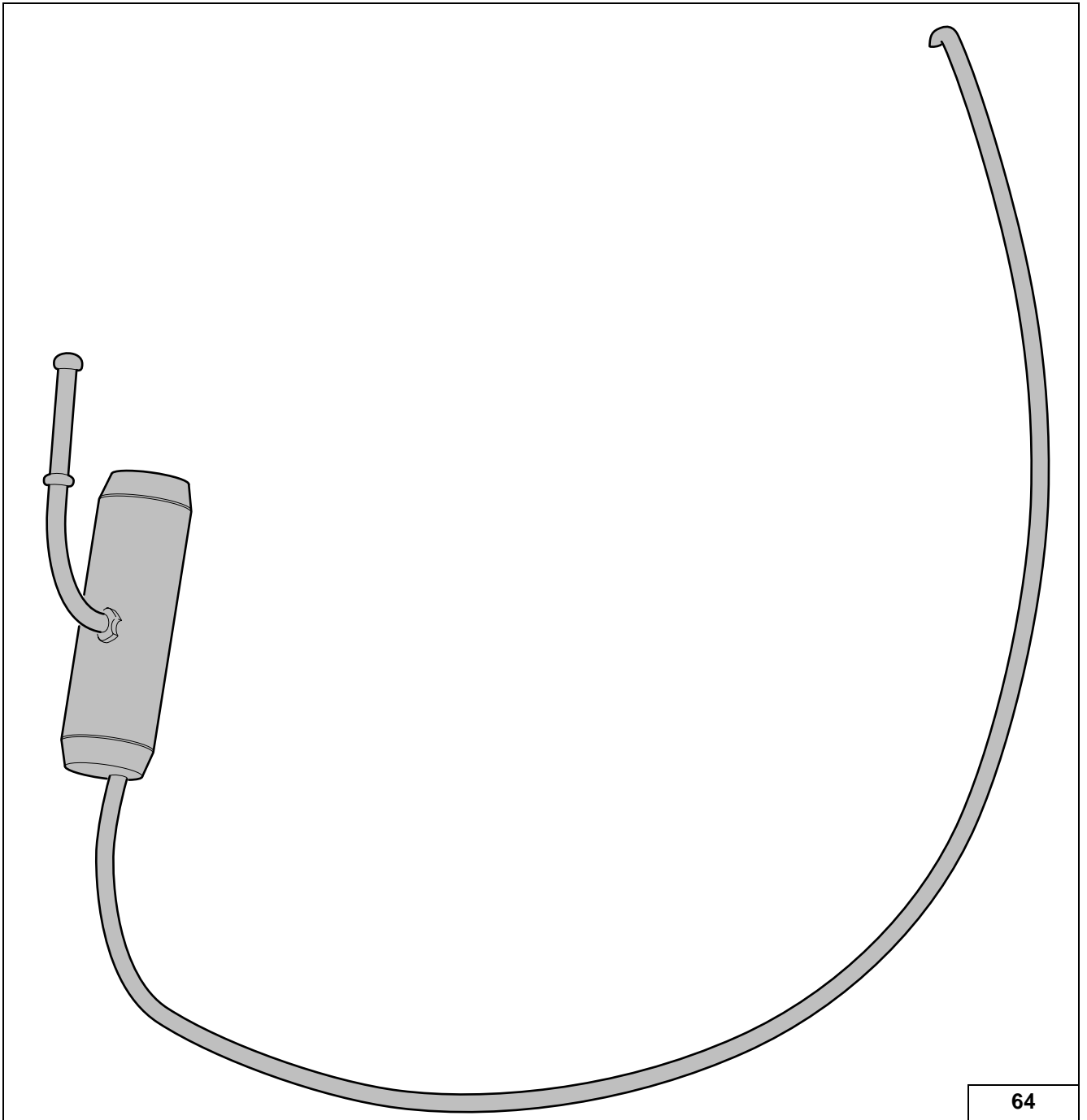

64