

Water Heater

Thermo Top Evo Parking Heater



Installation Documentation

Audi A4 / A5

Validity

Manufacturer	Model	Type	EG-BE No. / ABE
Audi	A4	B8	e1 * 2001 / 116 * 0430 * ...

Motorisation	Fuel	Transmission type	Output in kW	Displacement in cm ³	Engine code
1.8 TFSI	Petrol	SG	88	1798	CDHA
1.8 TFSI	Petrol	Multitronic	88	1798	CDHA
1.8 TFSI	Petrol	SG	118	1798	CABB
1.8 TFSI	Petrol	SG	125	1798	CJEB
2.0 TFSI	Petrol	SG	155	1984	CDNC
2.0 TFSI	Petrol	Multitronic	155	1984	CDNC
2.0 TFSI quattro	Petrol	S-tronic	155	1984	CDNC
2.0 TDI	Diesel	SG	88	1968	CAGC
2.0 TDI	Diesel	SG	100	1968	CJCB / CAGB
2.0 TDI	Diesel	S-tronic	105	1968	CAGA
2.0 TDI	Diesel	S-tronic	130	1968	CGLC

Manufacturer	Model	Type	EG-BE No. / ABE
Audi	A5	B8	e1 * 2001 / 116 * 0430 * ...

Motorisation	Fuel	Transmission type	Output in kW	Displacement in cm ³	Engine code
1.8 TFSI	Petrol	SG	125	1798	CJEB
1.8 TFSI	Petrol	Multitronic	125	1798	CJEB
2.0 TFSI	Petrol	SG	155	1984	CDNC
2.0 TFSI	Petrol	Multitronic	155	1984	CDNC
2.0 TFSI quattro	Petrol	S-tronic	155	1984	CDNC
2.0 TDI	Diesel	S-tronic	105	1968	CAGA
2.0 TDI	Diesel	S-tronic	130	1968	CGLC

SG = manual transmission

From Model Year 2008
Left-hand drive vehicle

Verified equipment variants: Automatic air-conditioning
 Front fog light
 Xenon / Headlight washer system

Not verified: Passenger compartment monitoring
 Manual air-conditioning system

Total installation time: about 7 hours

Audi A4 / A5

Table of Contents

Validity	1	Preparing Installation Location	11
Necessary Components	2	Preparing Heater	11
Installation Overview	2	Installing Heater	15
Information on Total Installation Time	2	Fuel	16
Information on Operating and Installation Instructions	3	Coolant Circuit Vehicle With Additional Circulating Pump	23
Information on Validity	4	Coolant Circuit Vehicle Without Additional Circulating Pump	24
Technical Instructions	4	Exhaust Gas	30
Explanatory Notes on Document	4	Final Work	31
Preliminary Work	5	Adaptation of Climatronic J255 Control Unit	31
Heater Installation Location	5	Operating Instructions for End Customer	32
Electrical System Fuse Holder Engine Compartment	6		
Electrical System Wiring Harness Routing	7		
Fan Controller	8		
Digital Timer	10		
Remote Option (Telestart)	10		

Necessary Components

- *Thermo Top Evo* basic delivery scope in accordance with the price list
- Installation kit for Audi A4 / A5 2008 Petrol and diesel: **1318637B**
- Heater control in accordance with price list and upon consultation with final customer
- In case of Telestart, Indicator lamp in accordance with price list and upon consultation with final customer

Installation Overview

Legend:

1. Heater
2. Fuse holder engine compartment
3. Circulating pump
4. Digital timer
5. Metering pump

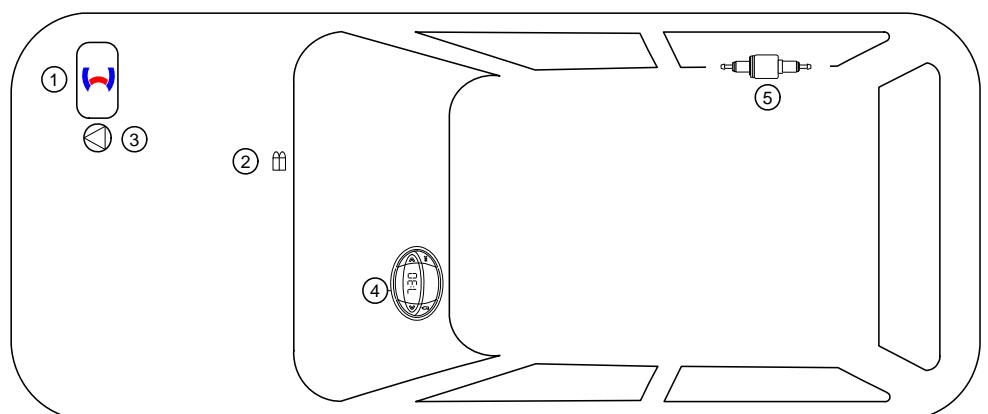

Information on Total Installation Time

The total installation time includes the time needed for mounting and demounting of the vehicle-specific components, the heater specific installation time and all other times required for the system integration and initial start-up of the heater.

The total installation time may vary for vehicle equipment other than provided.

Information on Operating and Installation Instructions

1 Important Information (not complete)

1.1 Installation and Repair



The improper installation or repair of Webasto heating and cooling systems can cause fire or the leakage of deadly carbon monoxide, leading to serious injury or death.



To install and repair Webasto heating and cooling systems you need to have completed a special company training course and have the appropriate technical documentation, special tools and special equipment.



Installation and repair may ONLY be carried out by persons trained and certified in a Webasto training course. NEVER try to install or repair Webasto heating or cooling systems if you have not completed a Webasto training course, you do not have the necessary technical skills and you do not have the technical documentation, tools and equipment available to ensure that you can complete the installation and repair work properly.

Only use genuine Webasto parts. See the Webasto air and water heaters accessories catalogue for this purpose.

1.2 Operation

To ensure safe operation, we recommend having the heater checked every two years by an authorised Webasto dealer, especially when used over a long period and/or under extreme environmental conditions.

Do not operate the heater in closed rooms due to the danger of poisoning and suffocation.

Always switch off the heater before refuelling.

The heater may only be used with the prescribed fuel Diesel (DIN EN 590) or petrol (DIN EN 227).

The heater may not be cleaned with a high-pressure cleaner.

1.3 Please note

ALWAYS follow all Webasto installation and operating instructions and observe all warnings.

To become familiar with and understand all functions and properties of the heater, the operating instructions must be read carefully and observed at all times.

For proper, safe installation and repair work, the installation instructions with all warnings and safety information must be carefully read and observed at all times. Please always contact a workshop authorised by Webasto for all installation and repair work.

IMPORTANT

Webasto shall assume no liability for defects, damage and injuries resulting from a failure to observe the installation, repair and operating instructions of the information contained in them.

This liability exclusion particularly applies to improper installations and repairs, installations and repairs by untrained persons or in the case of a failure to use genuine spare parts.

The liability due to culpable disregard to life, limb or health and due to damage or injuries caused by a wilful or reckless breach of duty remain unaffected, as does the obligatory product liability.

Installation should be carried out according to the general, standard rules of technology. Unless specified otherwise, fasten hoses, lines and wiring harnesses to original vehicle lines and wiring harnesses using cable ties. Insulate loose wire ends and tie back.

Sharp edges should be fitted with rub protection (split-open fuel hose)! Spray unfinished body areas, e.g. drilled holes, with anti-corrosion wax (Tectyl 100K, Order No. 111329).

Observe the instructions and guidelines of the respective vehicle manufacturer for demounting and mounting vehicle specific components!

The initial startup is to be executed with the Webasto Thermo Test Diagnosis.

When installing an IPCU, the corresponding settings must be checked or adjusted before the installation.

2 Statutory regulations governing installation

Guidelines	Thermo Top Evo
Heating Directive ECE R122	E1 00 0258
EMC Directive ECE R10	E1 03 5627

NOTE

The regulations of these guidelines are binding in the scope of the Directive 70/156/EEC and/or 2007/46/EC (for new vehicle models from 29/04/2009) and should also be observed in countries in which there are no special regulations.

IMPORTANT

Failure to follow the installation instructions will result in the invalidation of the type approval for the heater and therefore invalidation of the general **homologation of the vehicle**.

NOTE

For vehicles with an EU permit, no entry in accordance with § 19 Sub-Section 4 of Annex VIII b to the Road Traffic Act is required.

2.1 Excerpt from the directive 2001/56/EC Appendix VII for the installation of the heater

Beginning of excerpt.

ANNEX VII

REQUIREMENTS FOR COMBUSTION HEATERS AND THEIR INSTALLATION

1. GENERAL REQUIREMENTS

1.7.1. A clearly visible tell-tale in the operator's field of view shall inform when the combustion heater is switched on or off.

2. VEHICLE INSTALLATION REQUIREMENTS

2.1. Scope

2.1.1. Subject to paragraph 2.1.2. combustion heaters shall be installed according to the requirements of this Annex.

2.1.2. Vehicles of category O having liquid fuel heaters are deemed to comply with the requirements of this Annex.

2.2. Positioning of heater

2.2.1. Body sections and any other components in the vicinity of the heater must be protected from excessive heat and the possibility of fuel or oil contamination.

2.2.2. The combustion heater shall not constitute a risk of fire, even in the case of overheating. This requirement shall be deemed to be fulfilled if the installation ensures an adequate distance to all parts and suitable ventilation, by the use of fire resistant materials or by the use of heat shields.

2.2.3. In the case of M2 and M3 vehicles, the heater must not be positioned in the passenger compartment. However, an installation in an effectively sealed envelope which also complies with the conditions in paragraph 2.2.2 may be used.

2.2.4. The label referred to in paragraph 1.4 or a duplicate, must be positioned so that it can be easily read when the heater is installed in the vehicle.

2.2.5. Every reasonable precaution should be taken in positioning the heater to minimise the risk of injury and damage to personal property.

2.3. Fuel supply

2.3.1. The fuel filler must not be situated in the passenger compartment and must be provided with an effective cap to prevent fuel spillage.

2.3.2. In the case of liquid fuel heaters, where a supply separate to that of the vehicle is provided, the type of fuel and its filler point must be clearly labelled.

2.3.3. A notice, indicating that the heater must be shut down before refuelling, must be affixed to the fuelling point. In addition a suitable instruction must be included in the manufacturer's operating manual.

2.4. Exhaust system

2.4.1. The exhaust outlet must be located so as to prevent emissions from entering the vehicle through ventilators, heated air inlets or opening windows.

2.5. Combustion air inlet

2.5.1. The air for the combustion chamber of the heater must not be drawn from the passenger compartment of the vehicle.

2.5.2. The air inlet must be so positioned or guarded that blocking by rubbish or luggage is unlikely.

2.6. Heating air inlet

2.6.1. The heating air supply may be fresh or recirculated air and must be drawn from a clean area not likely to be contaminated by exhaust fumes emitted either by the propulsion engine, the combustion heater or any other vehicle source.

2.6.2. The inlet duct must be protected by mesh or other suitable means.

2.7. Heating air outlet

2.7.1. Any ducting used to route the hot air through the vehicle must be so positioned or protected that no injury or damage could be caused if it were to be touched.

2.7.2. The air outlet must be so positioned or guarded that blocking by rubbish or luggage is unlikely.

End of excerpt.

In multilingual versions the German language is binding.

Audi A4 / A5

Information on Validity

This installation documentation applies to Audi A4 / A5 Petrol and diesel vehicles - for validity, see page 1 - from model year 2008 and later, assuming technical modifications to the vehicle do not affect installation, any liability claims excluded. Depending on the vehicle version and equipment, modifications may be necessary during installation with respect to this installation documentation.

Vehicle and engine types, equipment variants and other specifications not listed in this installation documentation have not been tested. However, installation according to this installation documentation may be possible.

Technical Instructions

Special Tools

- Hose clamp pliers for self-clamping hose clamps
- Hose clamp pliers for Clic hose clamps of type W
- Automatic wire stripper 0.2 - 6mm²
- Crimping pliers for cable lug / tab connector 0.5 - 6mm²
- Torque wrench for 2.0 - 10 Nm
- Hose clamping pliers
- Drilling depth limiter
- 60mm dia. stepped drill bit
- Metric thread-setter kit
- Webasto Thermo Test diagnosis with current software

Measurements

- All measurements are in mm.

Tightening torque values

- Tightening torque values of 5x13 heater bolts = 8Nm.
- Tightening torque values of 5x15 retaining plate and water connection piece bolts = 7Nm.
- Tighten other screw connections in accordance with manufacturer's instructions or in accordance with state-of-the-art-technology.

Explanatory Notes on Document

You will find an identification mark on the outside top right corner of the page in question to provide you with a quick overview of the individual working steps.

Special features are highlighted using the following symbols:

Mechanical system



Electrical system



Coolant circuit



Combustion air

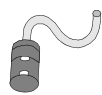

Fuel



Exhaust gas



Software



Specific risk of injury or fatal accidents



Specific risk of damage to components



Specific risk of fire or explosion.



Reference to general installation instructions of the Webasto components or to the manufacturer's vehicle-specific documents



Reference to a special technical feature



The arrow in the vehicle icon indicates the position on the vehicle and the viewing angle

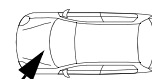
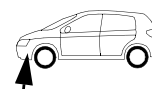

Audi A4 / A5

Preliminary Work

Vehicle

- Open the fuel tank cap.
- Ventilate the fuel tank.
- Close the fuel tank cap again.
- Depressurise the cooling system.
- Disconnect the battery.
- Remove the coolant reservoir cap.
- Remove the air filter box.
- Remove the right front wheel.
- Remove wheel-well inner panel on the right-hand side.
- Remove the front underride protection.
- Remove the underride protection on the right-hand side of the fuel line.
- Remove the rear right underride protection.
- Remove the rear bench seat.
- Remove the glove compartment (see installation instructions).
- Remove the side trim on the right-hand side of the A-pillar.
- Remove the loudspeaker cover on the right side of the instrument panel (only in case of Telestart).
- Remove the A/C control panel (see installation instructions).

Heater

- Remove years that do not apply from the type and duplicate label.
- Attach the duplicate label (type label) visibly in the appropriate place in the engine compartment.

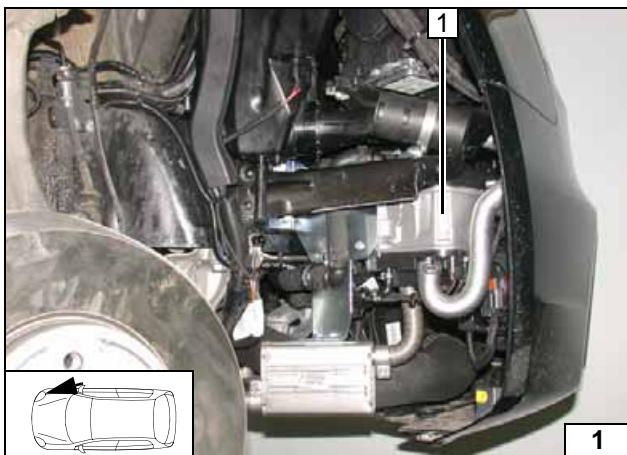

Heater Installation Location

1 Heater

Installation location



Electrical System Fuse Holder Engine Compartment



Audi A4 up to model year 2011

- 1 M5x16 bolt, washer [2x], nut
- 2 Angle bracket
- 3 M5x16 bolt, washer [2x], nut, existing hole
- 4 Fuses F1-2 (replace 30A fuse F2 with 3A fuse)

Audi A4 from model year 2012

- 1 M5x16 bolt, washer [2x], nut
- 2 Original vehicle stud bolt, M6 nut
- 3 Angle bracket
- 4 Fuses F1-2 (replace 30A fuse F2 with 3A fuse)

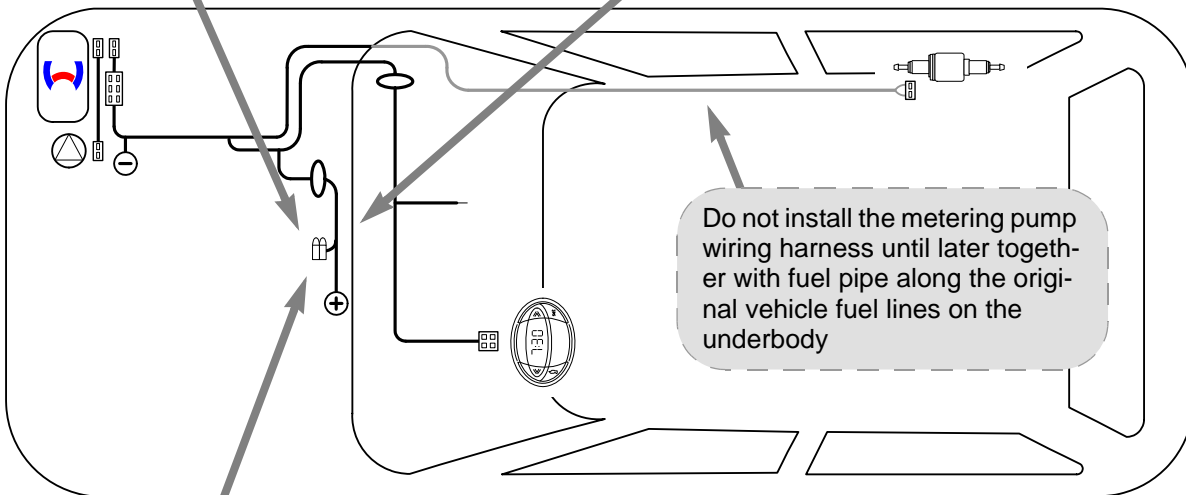
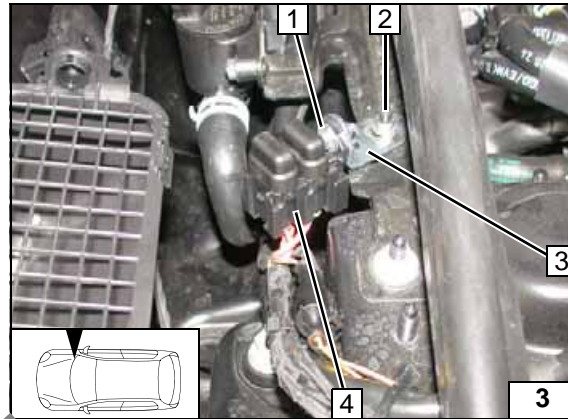
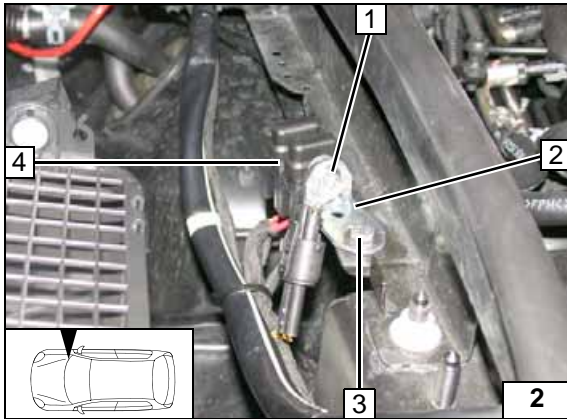

Wiring harness routing diagram

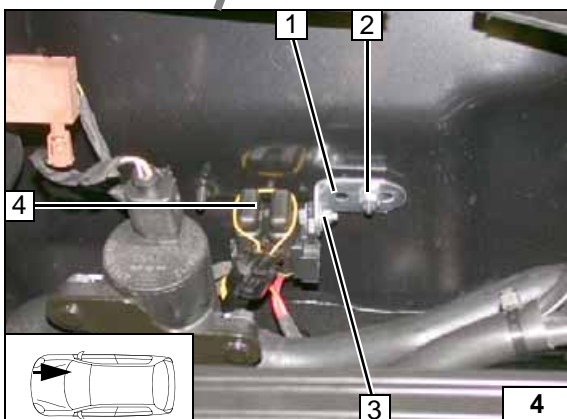

Audi A5 / A5 Cabrio

- 1 Angle bracket
- 2 Original vehicle stud bolt, M6 nut
- 3 M5x16 bolt, washer [2x], nut
- 4 Fuses F1-2 (replace 30A fuse F2 with 3A fuse)

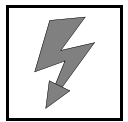

Electrical System Wiring Harness Routing

Wiring harness pass through

Route wiring harness of heater 1 to the passenger compartment through protective rubber plug on original vehicle wiring harness.

Wiring harness routing

- 1 Original vehicle protective rubber plug
- 2 Wiring harnesses of heater, heater control in 17mm dia. corrugated tube
- 3 Wiring harness of heater in original vehicle line duct
- 4 Wiring harness of heater control in 10mm dia. corrugated tube

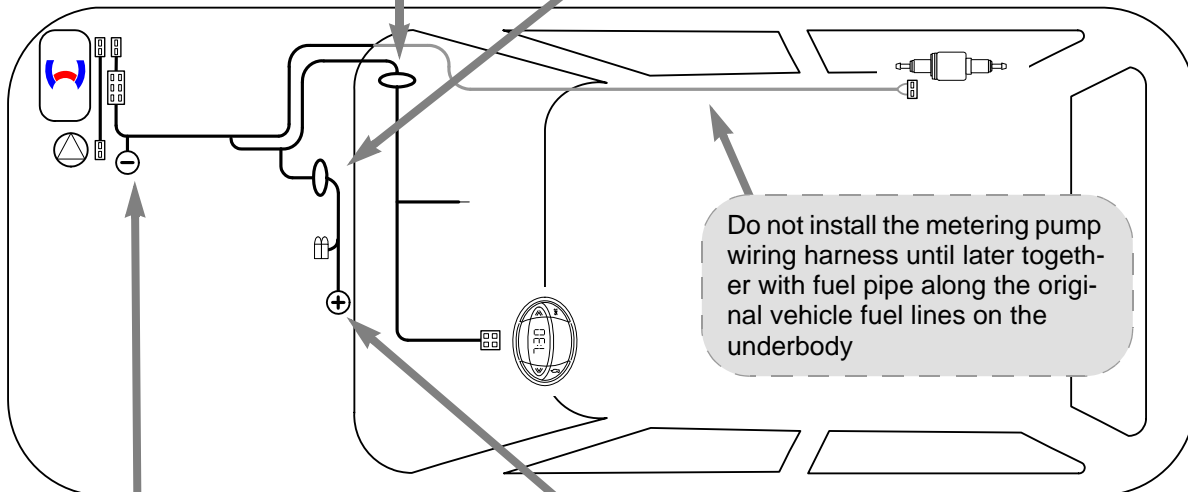
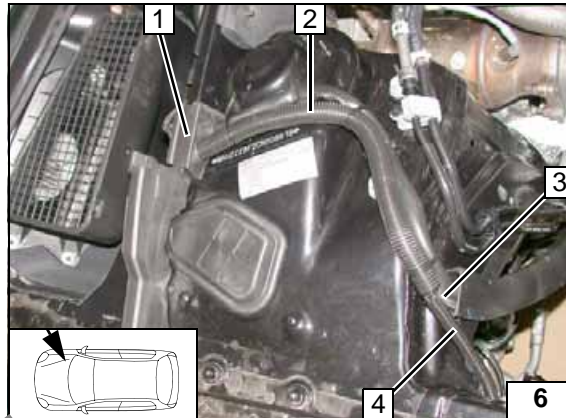
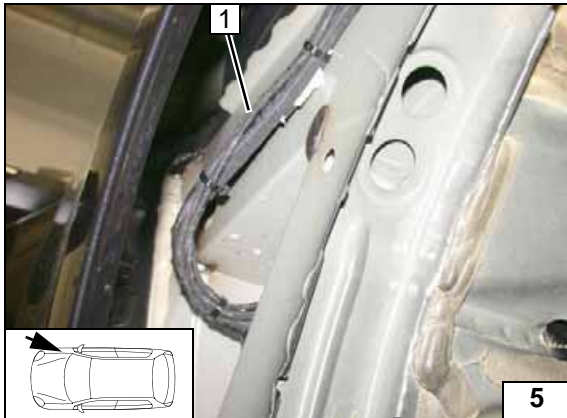

Wiring harness routing diagram

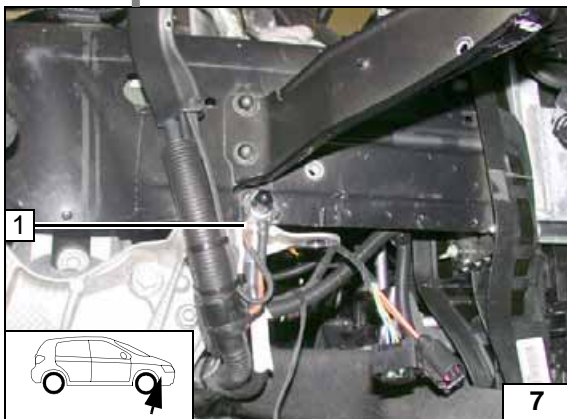

Earth wire

- 1 Earth wire on original vehicle earth support point

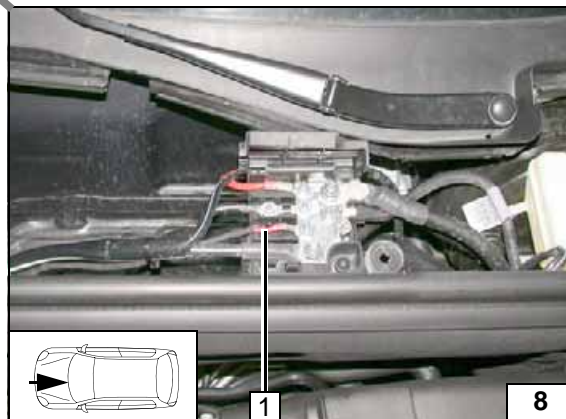

Positive wire

- 1 Positive wire on positive distributor of coolant reservoir



Fan Controller

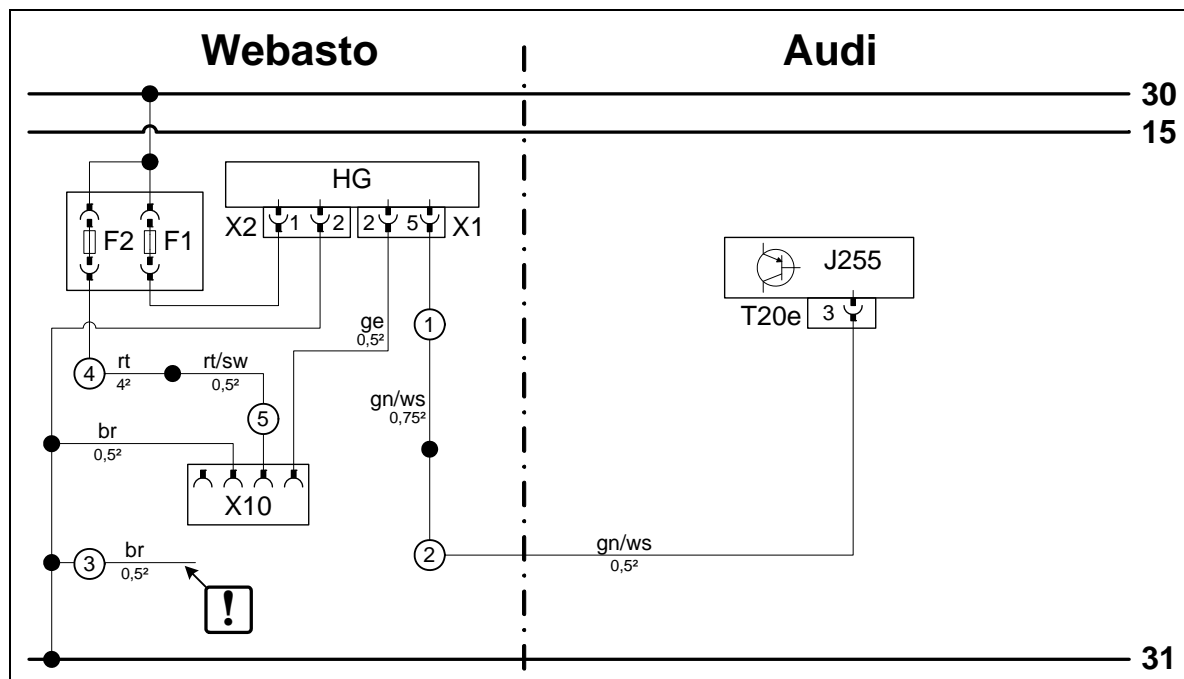

Wiring diagram

Webasto components		Vehicle components		Colours and symbols	
HG	Heater TT-Evo	J255	A/C control unit	rt	red
X1	6-pin heater connector	T20e	20-pin connector KB	sw	black
X2	2-pin heater connector			ge	yellow
X10	4-pin connector Heater control			gn	green
F1	20A fuse			br	brown
				ws	white
F2	Replace 30A with 3A fuse.			br	brown
					Insulate wire end and tie back
				X	Cutting point
				Wiring colours may vary.	

Legend



Loosen M6x16 bolt [6x, see markings]



Removing glove compartment

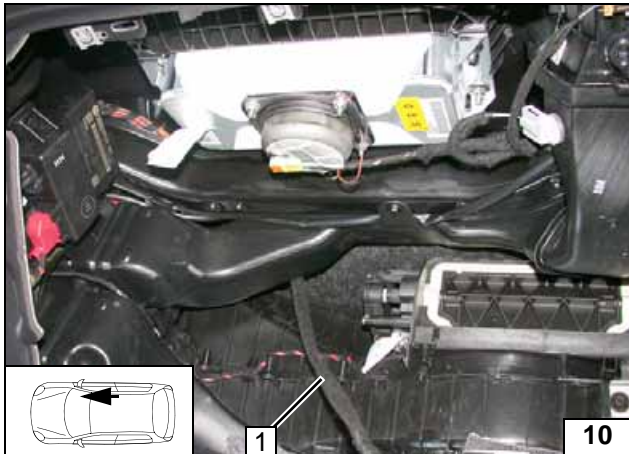

1 Wiring harness of heater control

Removing glove compartment

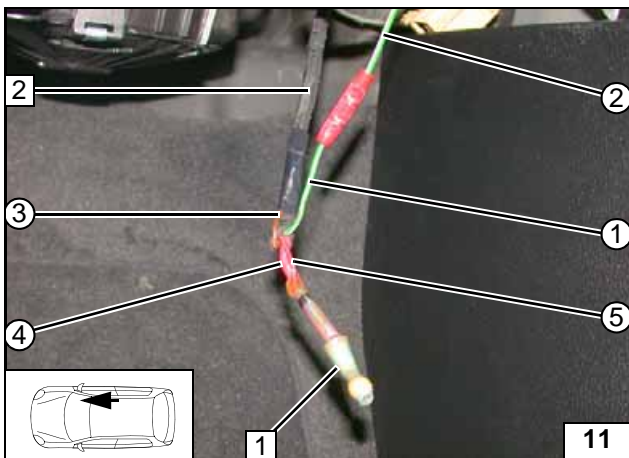

Insulate and tie back brown (br) wire ③. Pull wire section ② into protective sleeving and route it to the A/C control panel. Connect red (rt) 4² wire ④ and red/black (rt/sw) 0,5² wire ⑤ in accordance with the wiring diagram.



- 1 Soldering terminal connector
- 2 Wiring harness of heater control
- ① Green/white (gn/ws) wire X1/5
- ② Green/white (gn/ws) additional wire

Preparing wiring harness

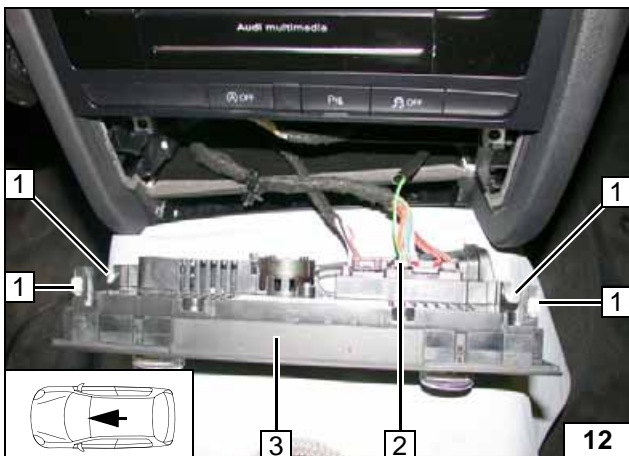

Pull out A/C control unit 3 opposite the driving direction. Remove 20-pin connector T20e 2.



- 1 Retaining clamps [4x]

Loosening A/C control unit

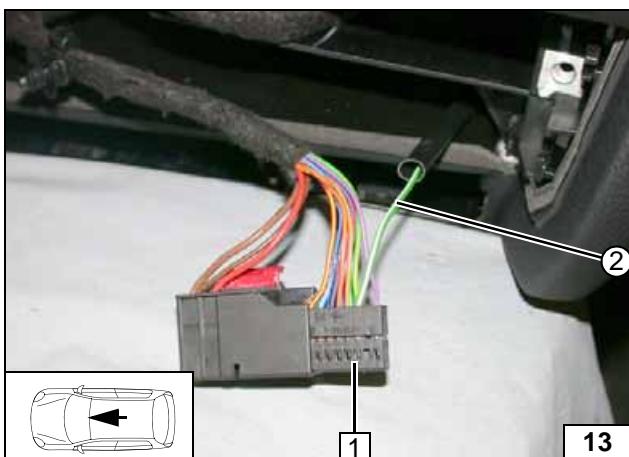

Connection to 20-pin connector 1 of A/C control unit Pin 3. Crimp socket contact onto green/white (gn/ws) wire ② and insert into socket of Pin 3.



Connection of A/C control unit



Digital Timer

- 1 Digital timer



Installing digital timer

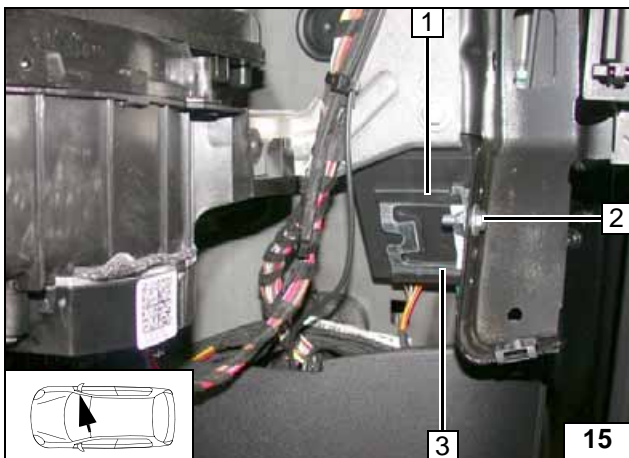

Remote Option (Telestart)

Bracket 3 bent at an angle of 90°.

- 1 Receiver
- 2 M5x16 bolt, washer [2x], M5 self-retaining nut



Installing receiver

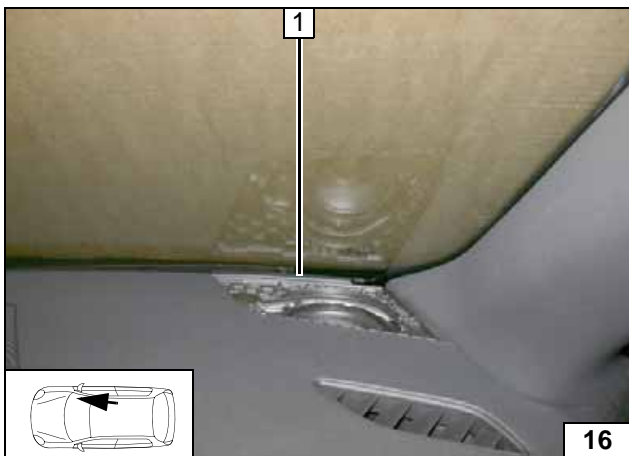

- 1 Antenna

Installing antenna

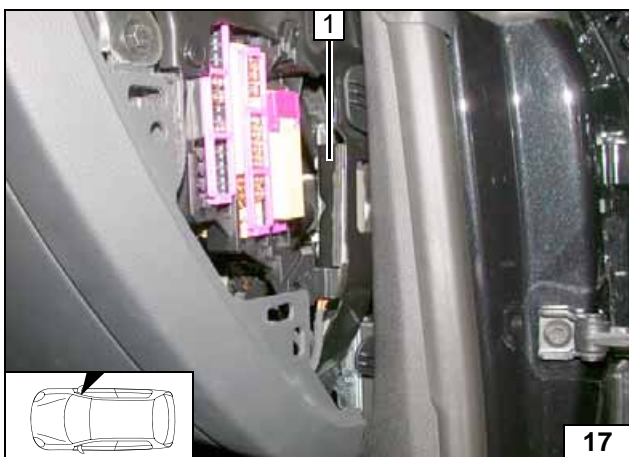

Temperature sensor T100 HTM

Fasten temperature sensor 1 with adhesive tape.



Installing temperature sensor

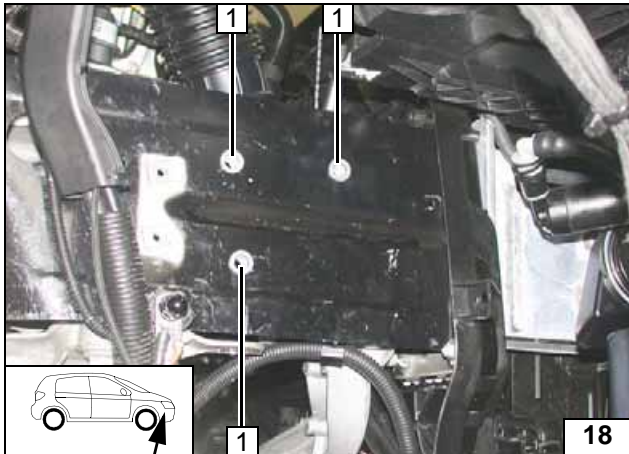
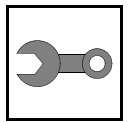

Preparing Installation Location

- 1 M8 rivet nut [3x], existing hole

Installing rivet nuts

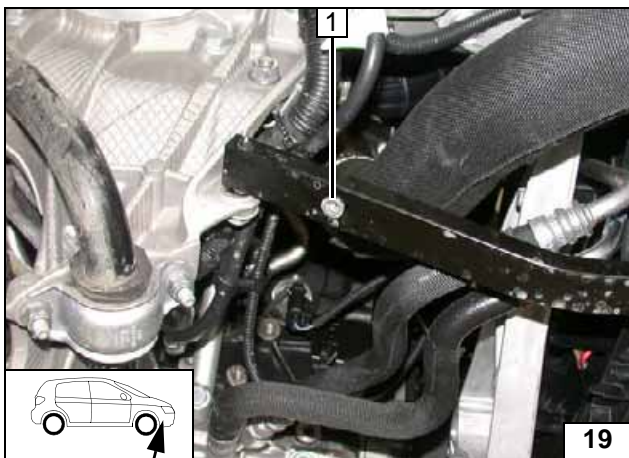

- 1 M6 rivet nut, existing hole

Installing rivet nut

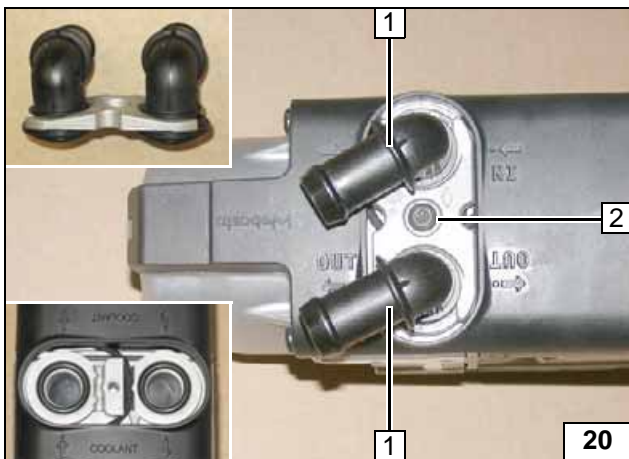

Preparing Heater

- 1 Water connection piece, sealing ring [2x each]
- 2 Self-tapping bolt 5x15mm, retaining plate, water connection piece



Assembling water connection piece

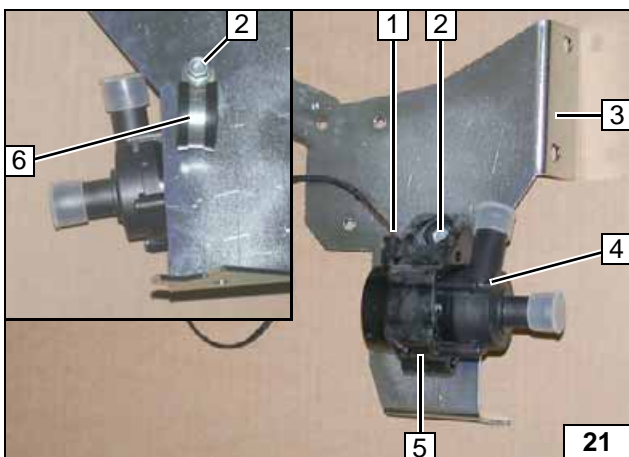

- 1 Attach wiring harness of circulating pump
- 2 M6x25 bolt, flanged nut
- 3 Bracket part 1
- 4 Circulating pump
- 5 Circulating pump mounting
- 6 25mm dia. rubber-coated p-clamp

Installing circulating pump

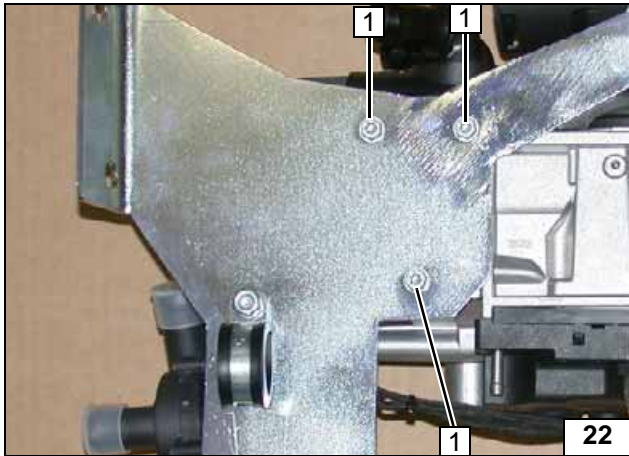

- 1 Self-tapping bolt 5x13 [3x]

Installing heater

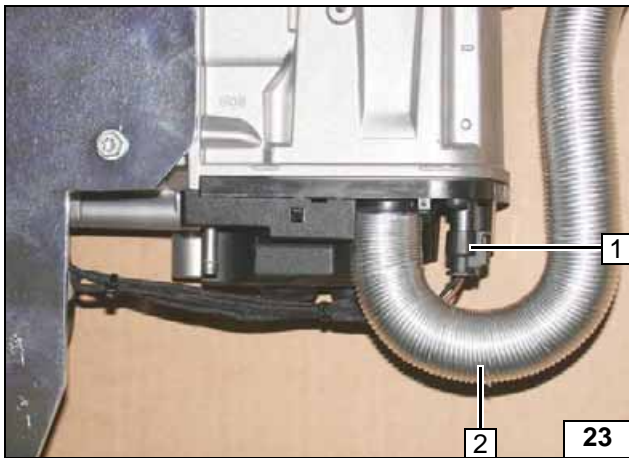

- 1 Mount wiring harness of circulating pump
- 2 Install combustion air pipe



Installing combustion air pipe

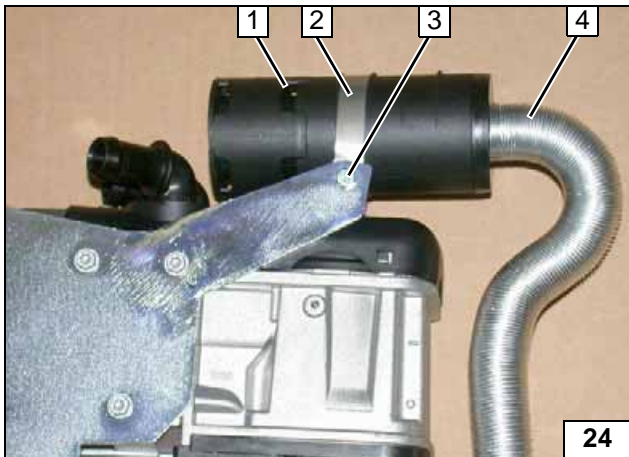

- 1 Combustion air silencer
- 2 51mm dia. clamp
- 3 M5x16 bolt, flanged nut
- 4 Combustion air pipe

Fastening combustion air silencer

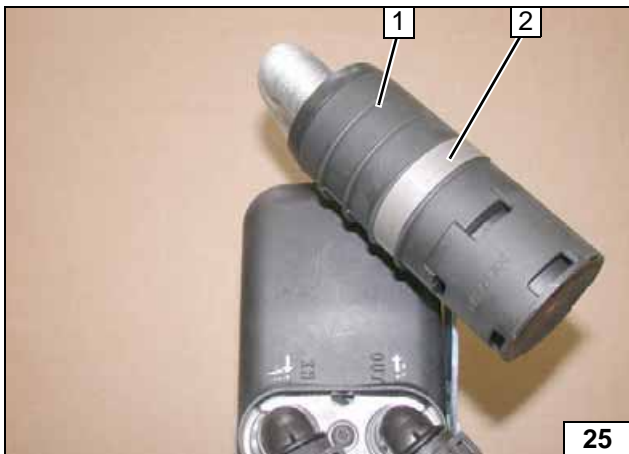

In case of vehicles with additional air intake on the air filter box, twist the combustion air silencer 1 with clamp 2.



Aligning combustion air silencer

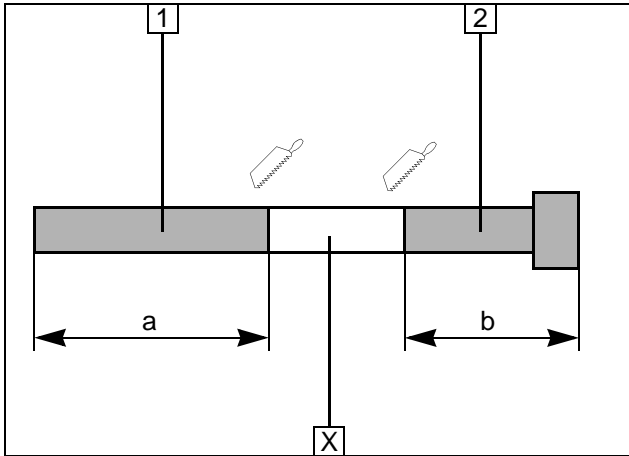
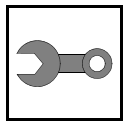

Discard section X.

- 1 Exhaust pipe
a = 130
- 2 Exhaust end section
b = 160



Preparing exhaust pipe

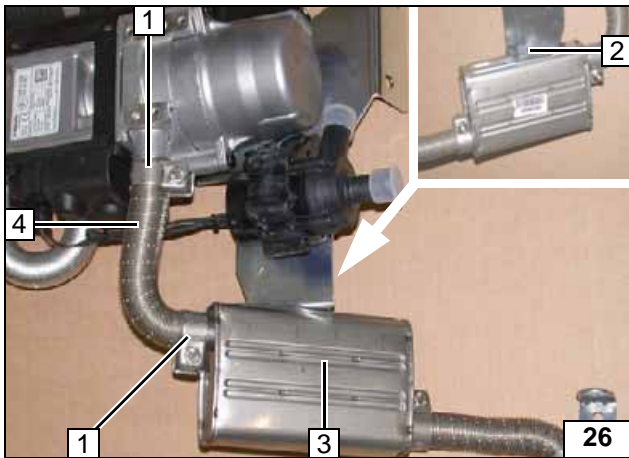

- 1 Hose clamp [2x]
- 2 M6x16 bolt, spring lockwasher
- 3 Exhaust silencer
- 4 Exhaust pipe

Installing exhaust silencer

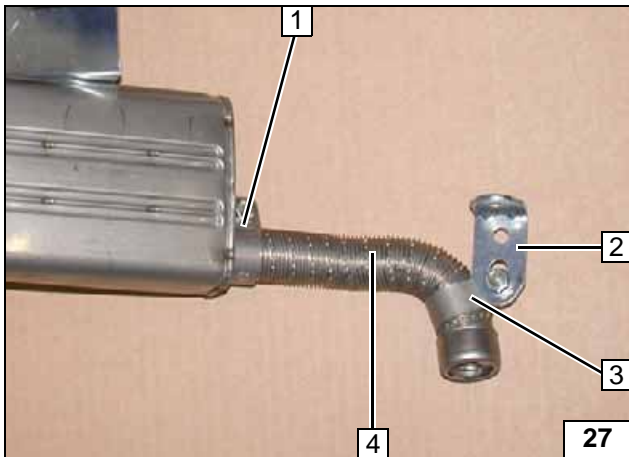

- 1 Hose clamp
- 2 Angle bracket, M6x20 bolt, flanged nut
- 3 P-clamp
- 4 Shape exhaust end section as shown

Installing exhaust pipe

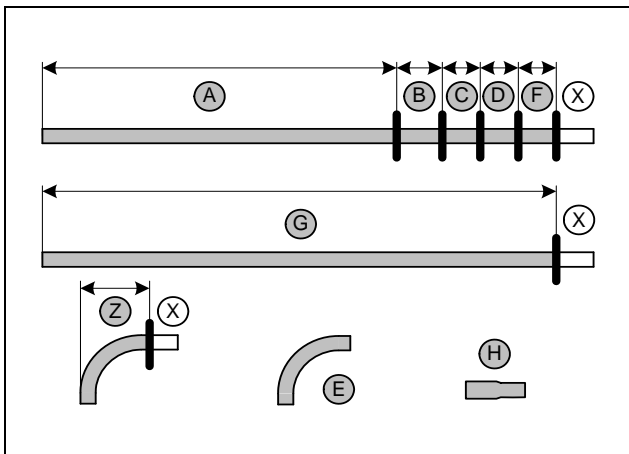

Discard section X.

- Hose E = 18x18 mm dia. 90° moulded hose
- Hose H = 18x20 mm dia. straight moulded hose
- Hose Z = 20x20mm dia. 90° moulded hose (only for vehicles with additional circulating pump)

- A = 1210
- B = 75
- C = 120
- D = 100
- F = 90
- G = 1430
- Z = 55



Cutting hoses to length

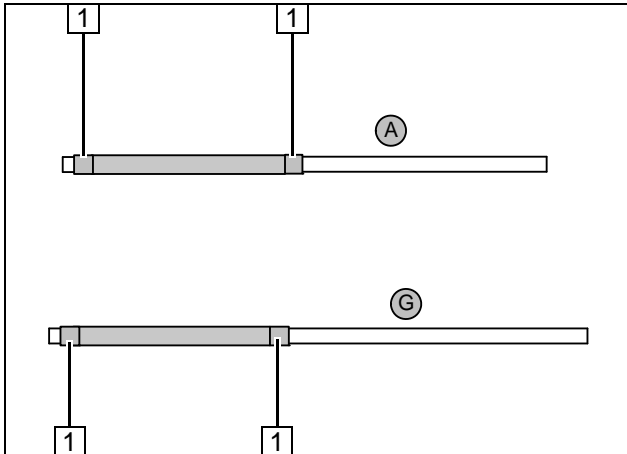

Centrally separate braided protection hoses and push them onto hoses **A** and **G**. Cut heat shrink plastic tubing to length.

- 1 25 mm long heat shrink plastic tubing [4x]



Preparing hoses

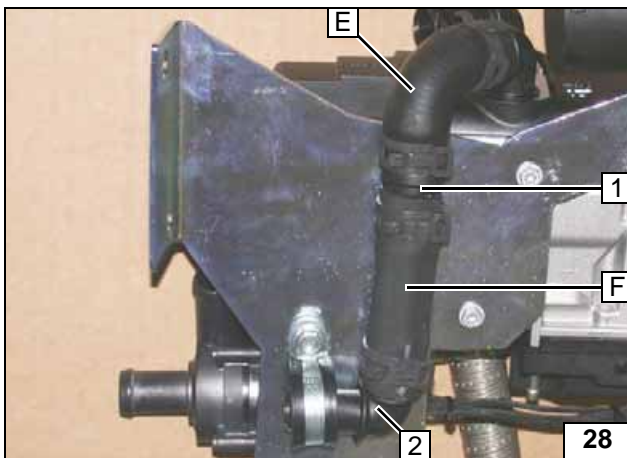

All spring clips = 25 mm dia.

- 1 18x18mm dia. connecting pipe
- 2 18x18mm dia. 90° connecting pipe



Connection of heater outlet

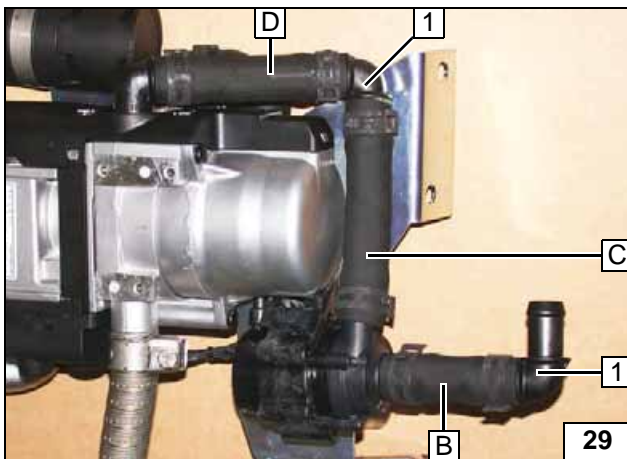

All spring clips = 25 mm dia.

- 1 18x18mm dia. 90° connecting pipe



Connection of heater inlet



Align bracket section 2 to be in parallel with bracket part 1.

- 1 Self-tapping bolt 5x13
- 2 Bracket part 2
- 3 Bracket part 1



Installing bracket part 2

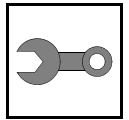

- 1 90° hose section, 10 mm dia. clamp [2x]
- 2 Fuel line

Installing fuel line

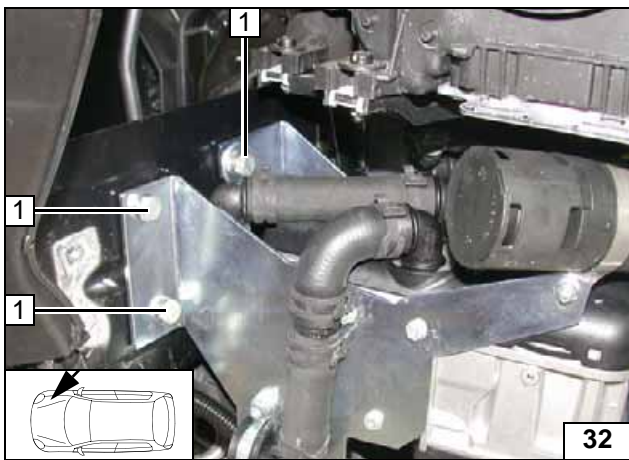

Installing Heater

- 1 M8x20 bolt [3x], spring lockwasher [3x]

Installing heater

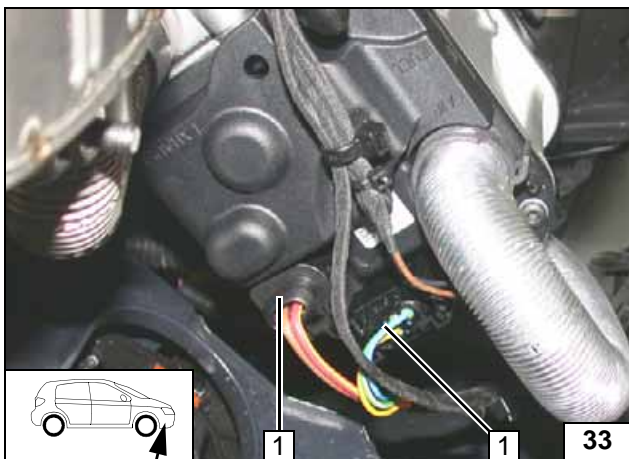

- 1 Wiring harness of heater [2x]

Attaching wiring harness



Fuel

CAUTION!

Open the vehicle's fuel tank cap, ventilate the tank and then re-close the tank lock.

Catch any fuel running off with an appropriate container.

Install fuel line and metering pump wiring harness so that they are protected against stone impact. Unless specified otherwise, always fasten using cable ties.

Mount the fuel line and wiring harness with rub protection on sharp edges.

WARNING!

The fuel line and wiring harness are routed to the metering pump as shown in the wiring harness routing diagram.

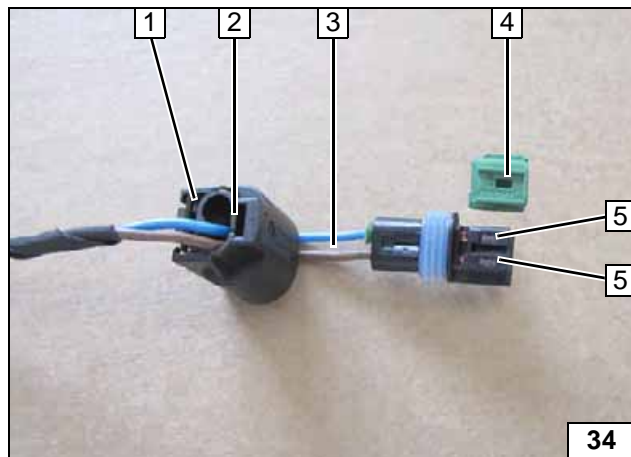

Complete connector of metering pump again after routing. Pin assignment is not relevant.

- 1 Connector housing
- 2 Lock
- 3 Blue/brown (bl/br) wires
- 4 Coding
- 5 Timer lock



Dismounting connector



Pull wiring harness of metering pump and fuel line into 10mm dia., 1130mm long corrugated tube 1.



Routing lines



1 Wiring harness of metering pump and fuel line in corrugated tube

Routing lines

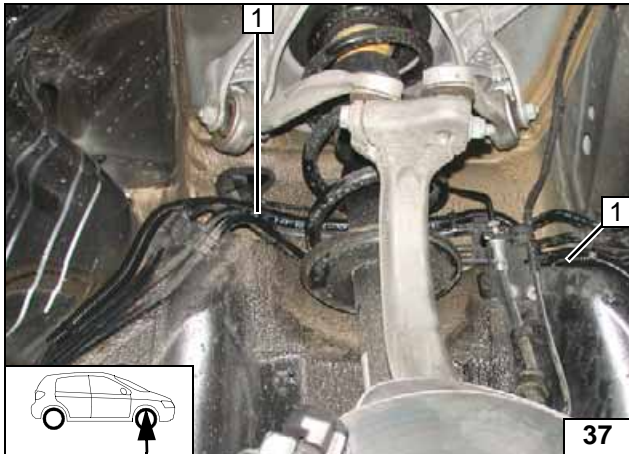

1 Wiring harness of metering pump and fuel line in corrugated tube

Routing lines

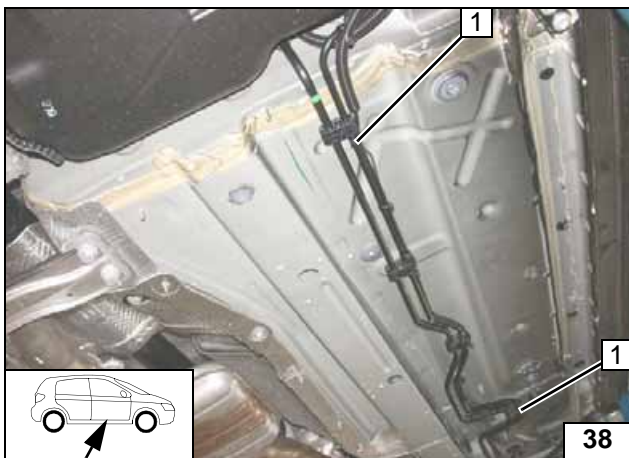

Route wiring harness of metering pump and fuel line to the installation location of the metering pump along original vehicle fuel lines.



Routing lines

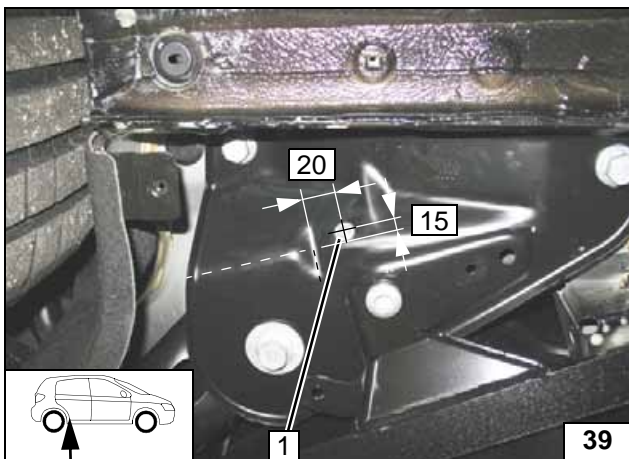

1 9.1 mm dia. hole; Rivet nut

Installing rivet nut

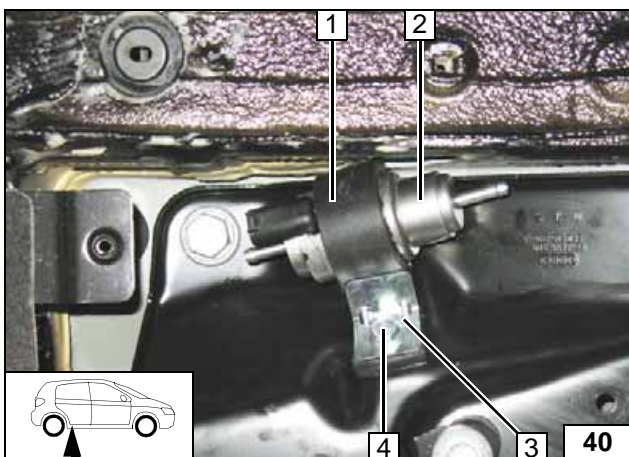

1 Mounting for metering pump
2 Metering pump
3 Support angle
4 M6x25 bolt



Installing metering pump

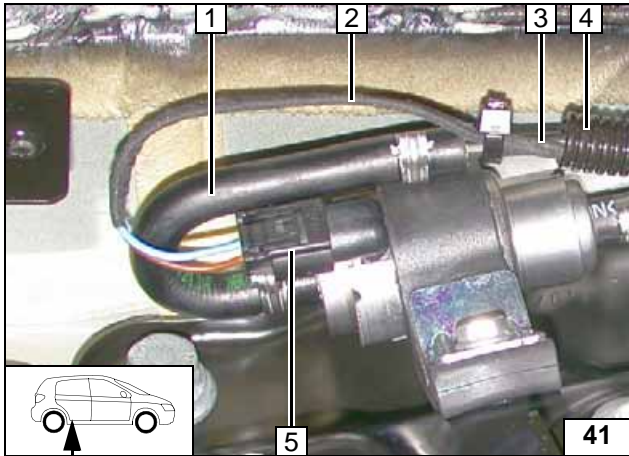

Cut 10mm dia. corrugated tube 4 to length by 630mm. Pull fuel line 3 and wiring harness 2 into corrugated tube.

- 1 180° moulded hose, 10 mm dia. clamp [2x]
- 5 Wiring harness of metering pump, connecting plug mounted



**Connect-
ing meter-
ing pump**

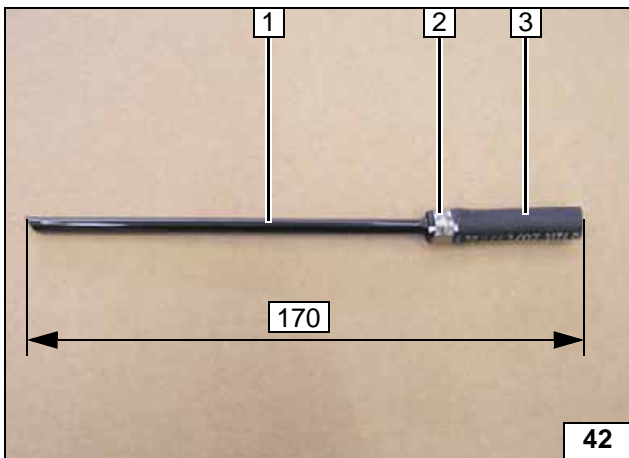

Petrol

The fuel-tank sending unit is dependent on the equipment and is differentiated between 2 versions.

All versions

Mount standpipe 1 in hose section 3 and fasten with 10mm dia. clamp 2 (between the beads). Cut standpipe 1 to length at the end at an angle.



**Preparing
fuel stand-
pipe**

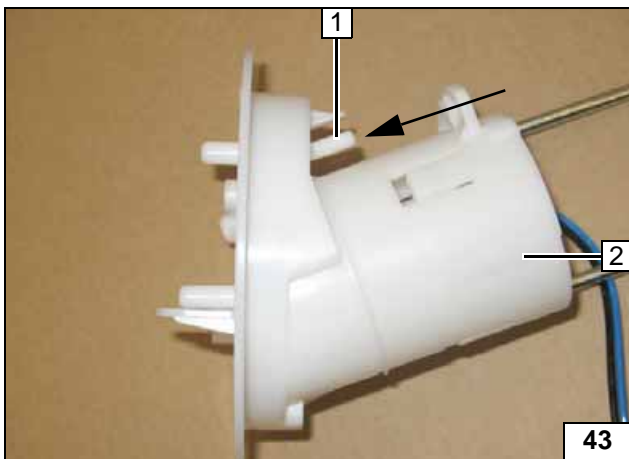

Version 1

Remove and dismantle fuel-tank sending unit 2 according to manufacturer's instructions. Limit drill bit, 2.0 mm dia., 125 long, to max. drilling depth of 25.5 mm and drill out connection piece 1 at centre. Do no drill through side wall!

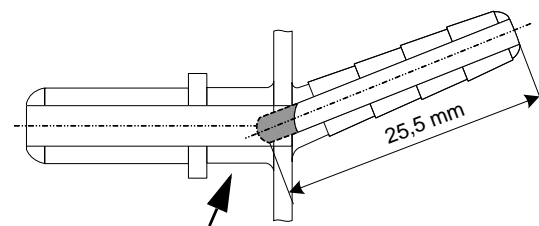

**Fuel ex-
traction**

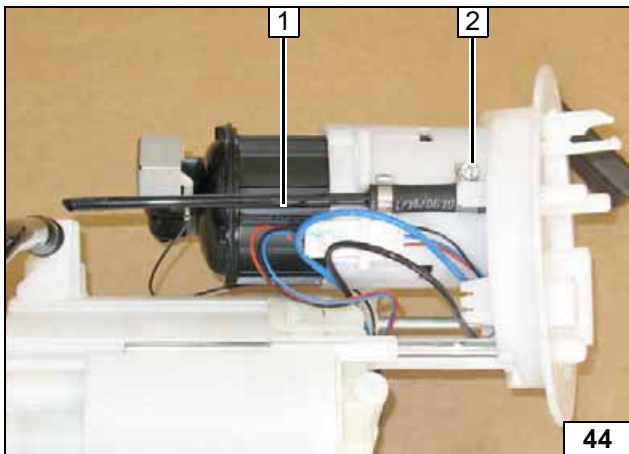

- 1 Fuel standpipe
- 2 10mm dia. clamp



**Installing
fuel stand-
pipe**

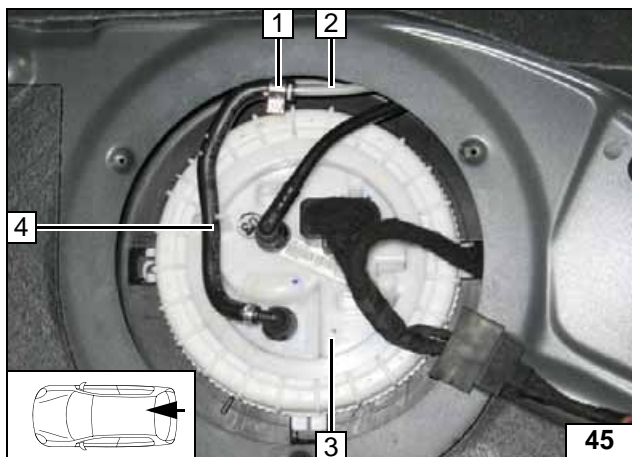

Install fuel-tank sending unit **3** in accordance with manufacturer's instructions. Mount quick-release coupling **4** on fuel standpipe. Route fuel line **2** to the installation location of the metering pump.

- 1 10mm dia. clamp



**Connect-
ing fuel line**

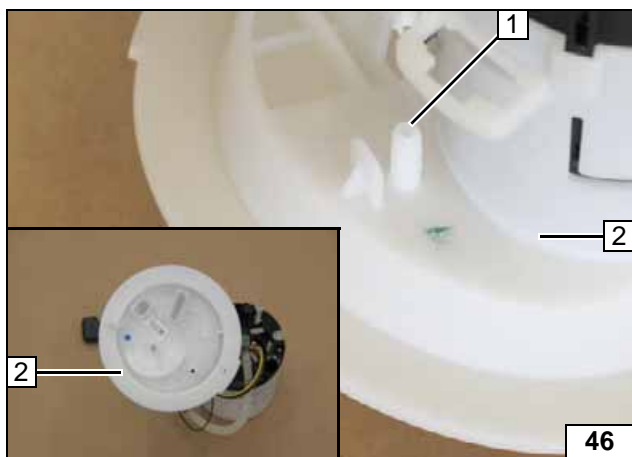

Version 2

Remove fuel-tank sending unit **2** according to manufacturer's instructions. Drill out connection piece **1** in centre to 2.5mm dia.



**Fuel ex-
traction**

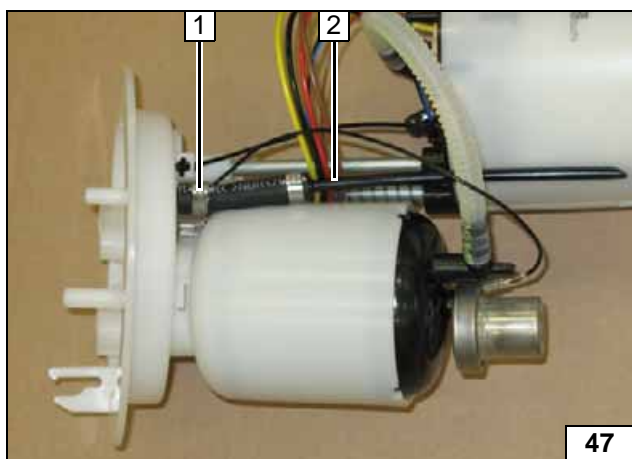

- 1 10 mm dia. clamp
- 2 Fuel standpipe



**Installing
fuel stand-
pipe**

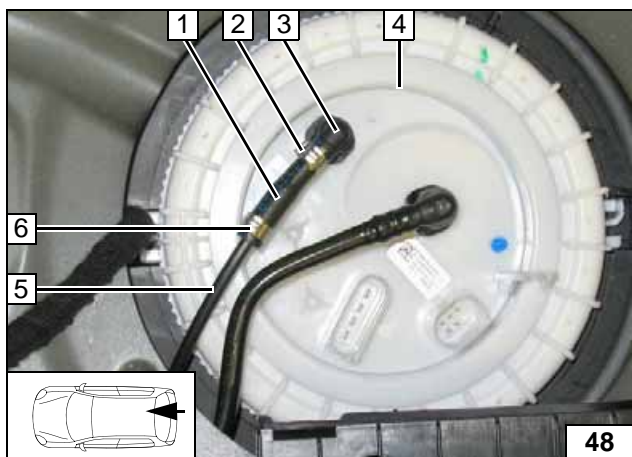

Install fuel-tank sending unit **4** in accordance with manufacturer's instructions. Route fuel line **5** to the installation location of the metering pump.

- 1 3.5x4.5mm dia. moulded hose
- 2 8mm dia. clamp
- 3 Quick-release coupling
- 6 10mm dia. clamp



**Connect-
ing fuel line**

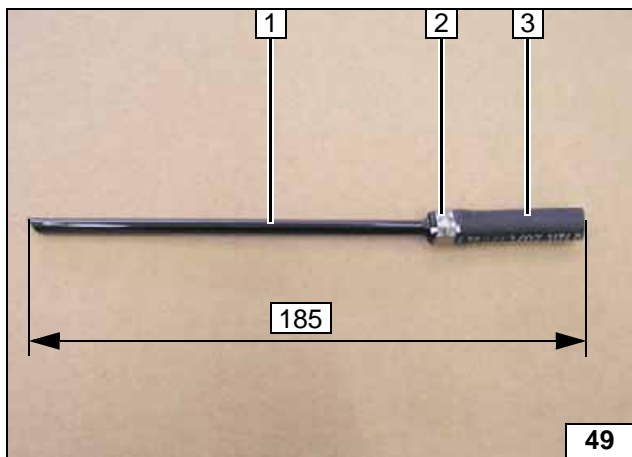

Diesel

The fuel-tank sending unit is dependent on the equipment and is differentiated between 2 versions.

All versions

Mount standpipe 1 in hose section 3 and fasten with 10mm dia. clamp 2 (between the beads). Cut standpipe 1 to length at the end at an angle.



Preparing fuel standpipe

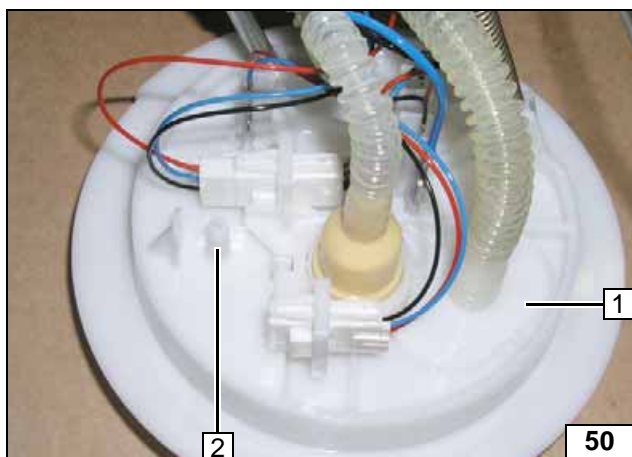

Version 1

Remove and dismantle fuel-tank sending unit 1 according to manufacturer's instructions. Drill out connection piece 2 at centre with 2.0 mm dia. drill bit.



Fuel extraction

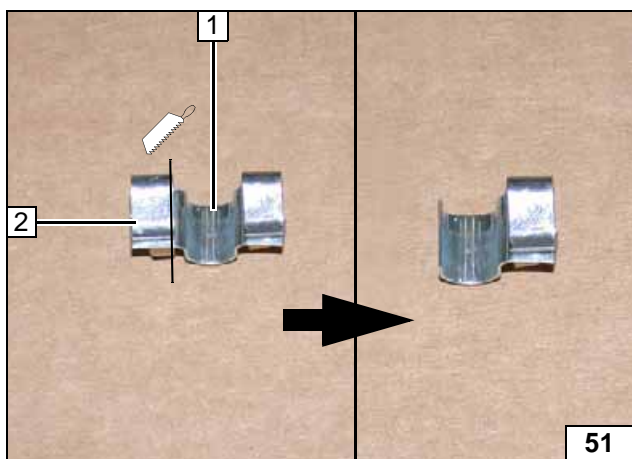

Cut retaining clamp 1 at marking.

2 Discard section



Cutting retaining clamp

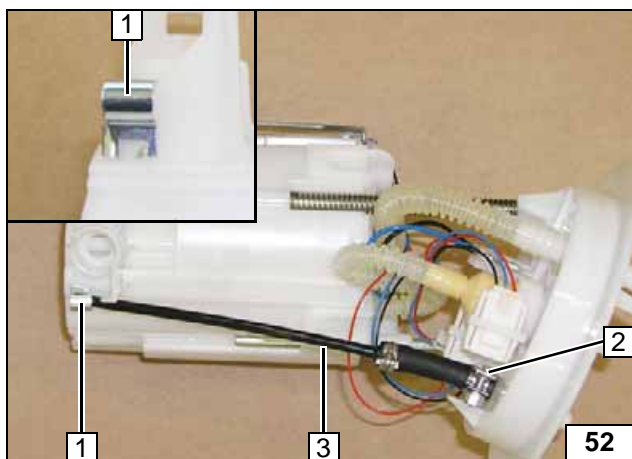

The installation of the retaining clamp depends on the equipment and is not possible with all fuel-tank sending units. Mount retaining clamp 1 on fuel-tank sending unit.

- 2 10 mm dia. clamp
- 3 Fuel standpipe



Installing fuel standpipe

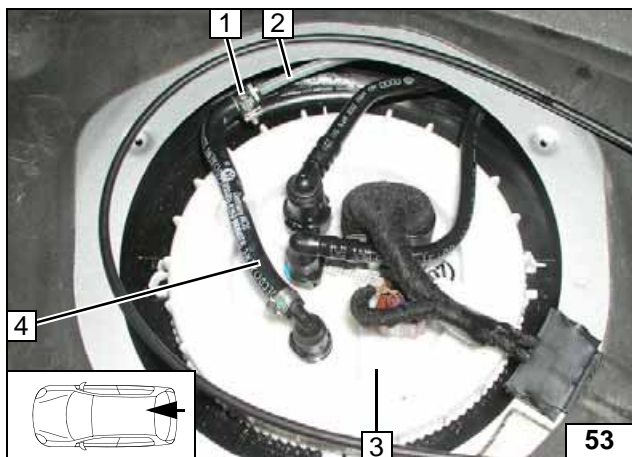

Install fuel-tank sending unit **3** in accordance with manufacturer's instructions. Mount quick-release coupling **4** on fuel standpipe. Route fuel line **2** to the installation location of the metering pump.

- 1 10mm dia. clamp



**Connect-
ing fuel line**

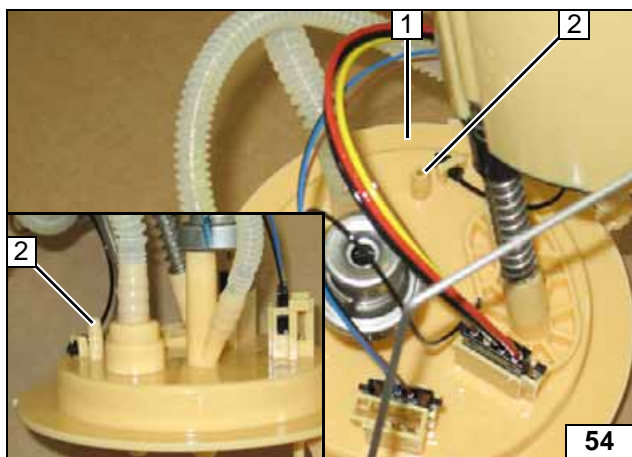

Version 2

Remove fuel-tank sending unit **1** according to manufacturer's instructions. Drill out connection piece **2** in centre to 2.5mm dia.



**Fuel ex-
traction**

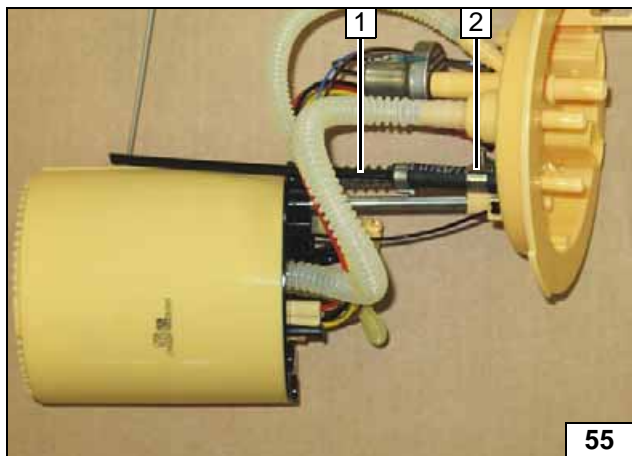

- 1 Fuel standpipe
- 2 10 mm dia. clamp



**Installing
fuel stand-
pipe**

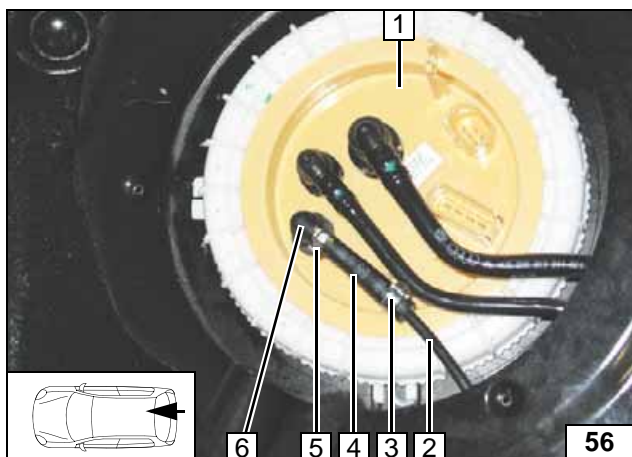

Install fuel-tank sending unit **1** in accordance with manufacturer's instructions. Route fuel line **2** to the installation location of the metering pump.

- 3 10mm dia. clamp
- 4 3.5x4.5mm dia. moulded hose
- 5 8mm dia. clamp
- 6 Quick-release coupling



**Connect-
ing fuel line**

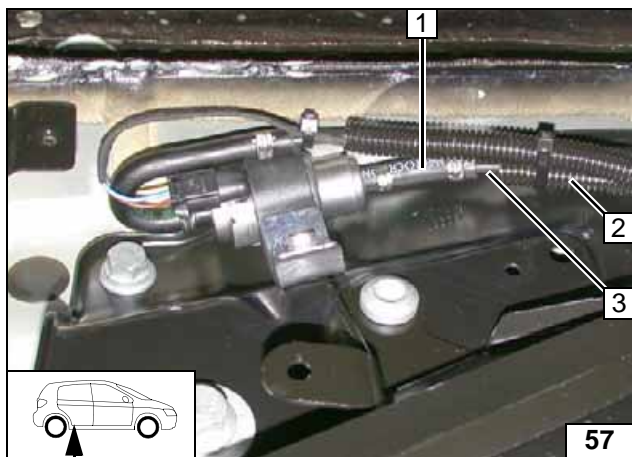
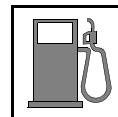

Petrol and Diesel

Push 10mm dia. corrugated tube **2** onto fuel line **3**. Check the position of the components; adjust if necessary. Check that they have freedom of movement.

- 1 Hose section, 10 mm dia. clamp [2x]



**Connect-
ing meter-
ing pump**





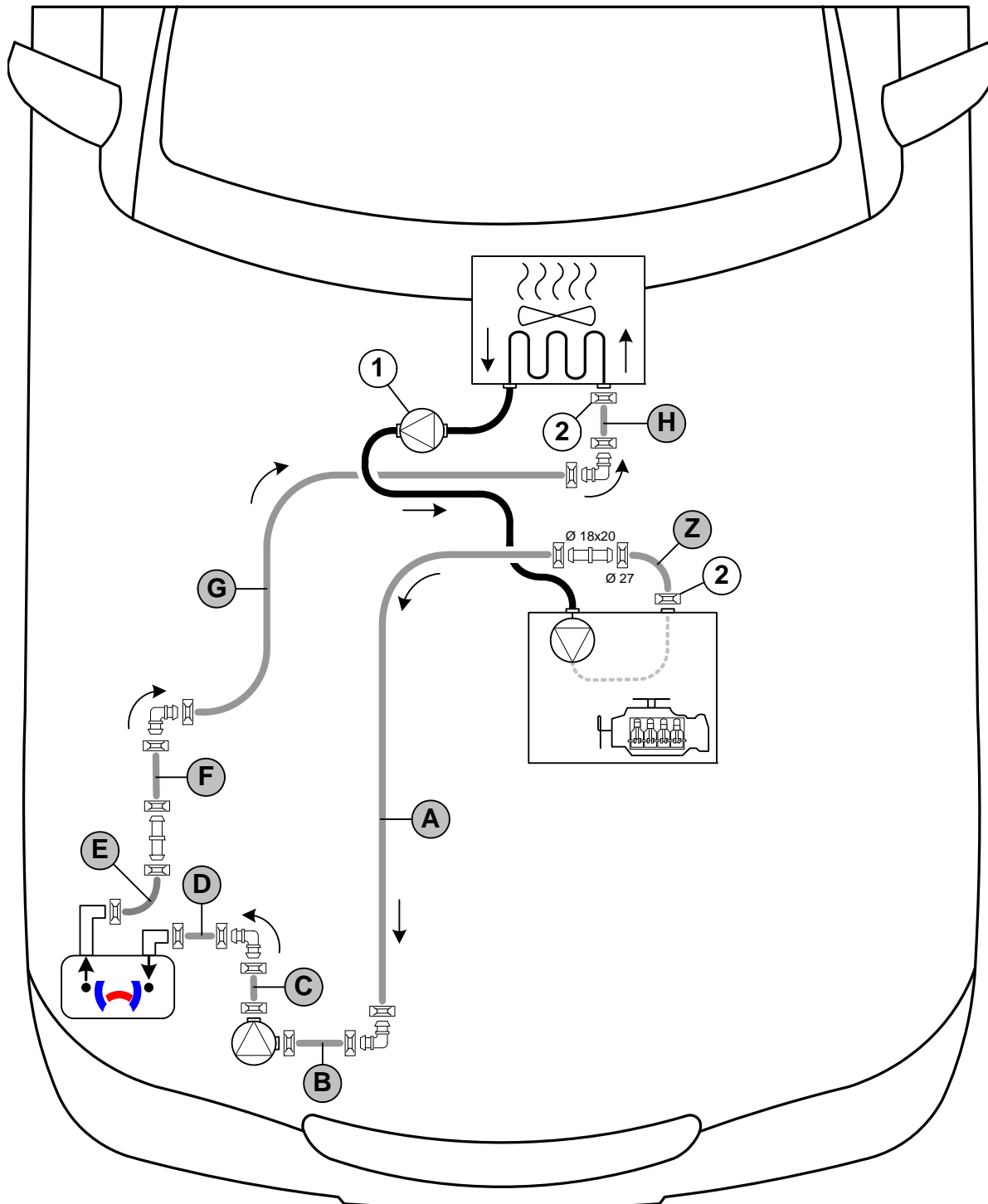

Coolant Circuit Vehicle With Additional Circulating Pump

WARNING!

Any coolant running off should be collected using an appropriate container. Install hoses so that they are kink-free. Unless specified otherwise, always fasten using cable ties. Position clamps so that other hoses cannot be damaged. The heater must be filled with coolant when installing the hoses. The connection should be "inline" based on the following diagram:



Hose installation diagram

All spring clips without a specific designation  = 25 mm dia. **2** = Original vehicle spring clip .
1 = Original vehicle circulating pump (depends on equipment, not installed in every vehicle).
 All connecting pipes without a specific designation  and  = 18x18 mm dia.





Coolant Circuit Vehicle Without Additional Circulating Pump





WARNING!

Any coolant running off should be collected using an appropriate container. Install hoses so that they are kink-free. Unless specified otherwise, always fasten using cable ties. Position clamps so that other hoses cannot be damaged. The heater must be filled with coolant when installing the hoses. The connection should be "inline" based on the following diagram:

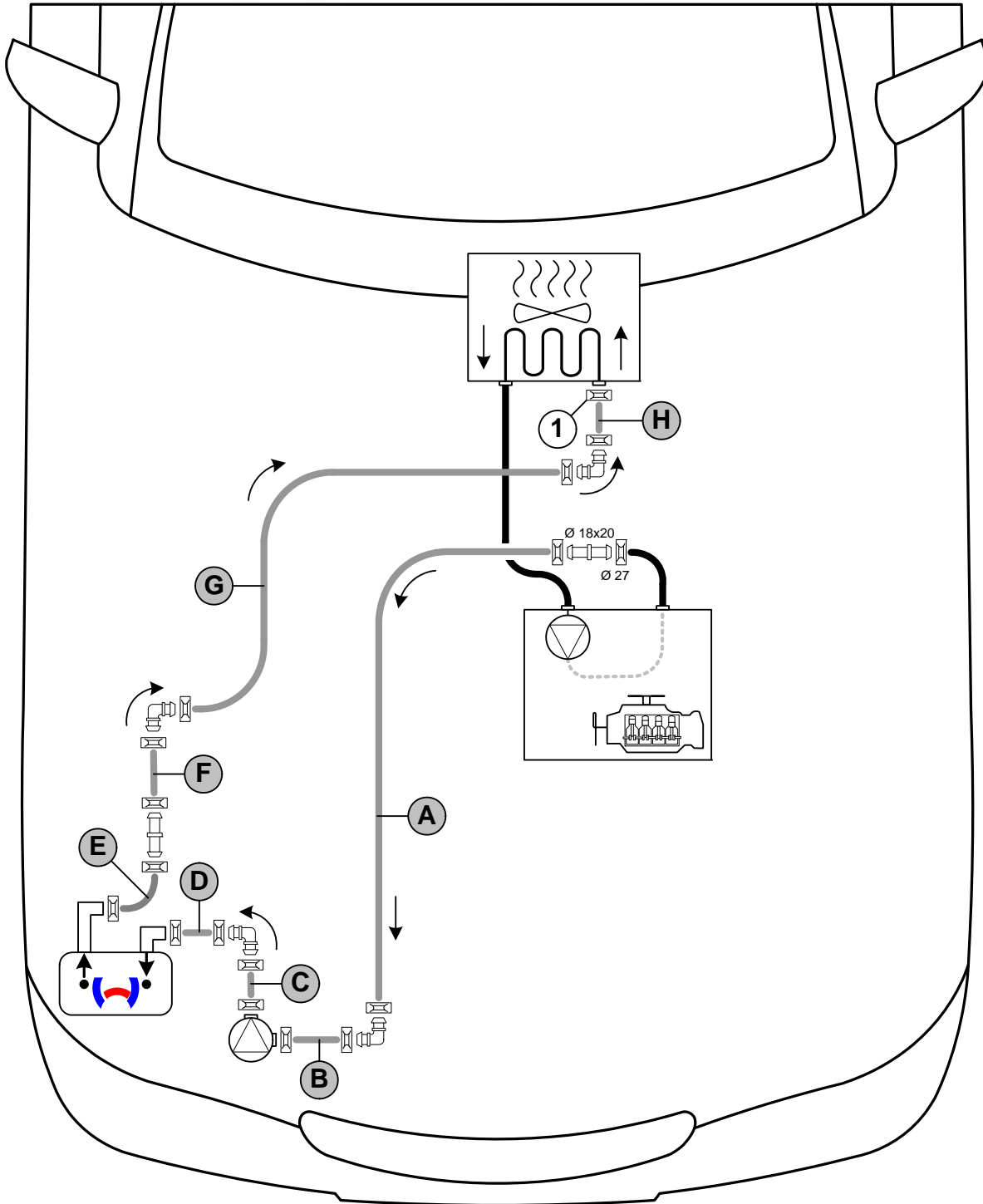

Hose installation diagram



All spring clips without a specific designation  = 25 mm dia. **1** = Original vehicle spring clip .
 All connecting pipes without a specific designation  and  = 18x18 mm dia.



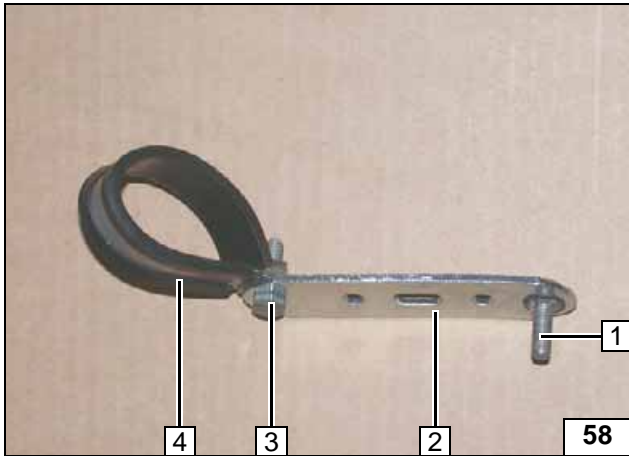

All vehicles

- 1 M6x20 bolt, pin lock
- 2 Perforated bracket
- 3 M6x20 bolt, flanged nut
- 4 38mm dia. rubber-coated pipe clamp

Premounting p-clamp

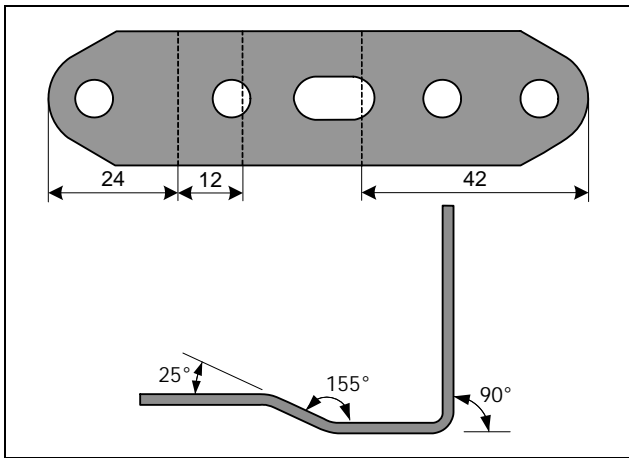

Shape perforated bracket in accordance with specifications.



Preparing perforated bracket

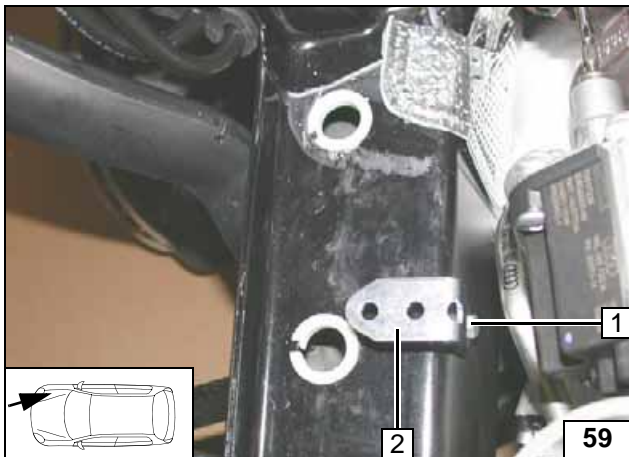

- 1 M6x20 bolt, spring lockwasher
- 2 Perforated bracket

Installing perforated bracket

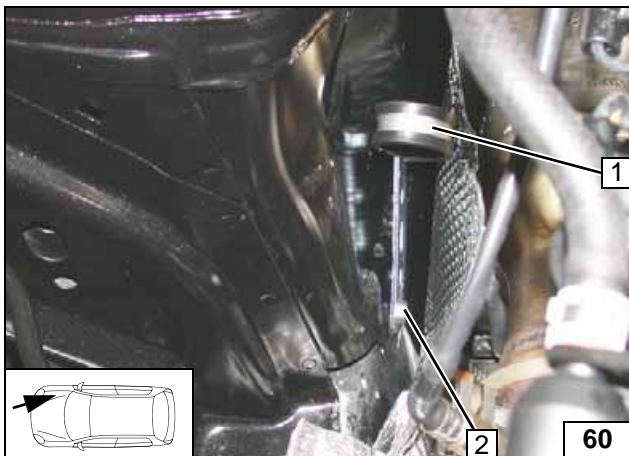

Mount premounted p-clamp 1 to existing hole.

- 2 M6x20 bolt, washer, flanged nut



Installing rubber-coated p-clamp

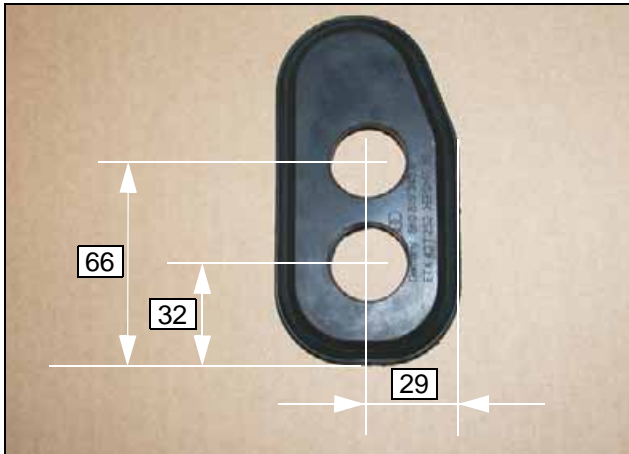

Punch 24mm dia. holes [2x] into grommet



Preparing grommet of coolant reservoir

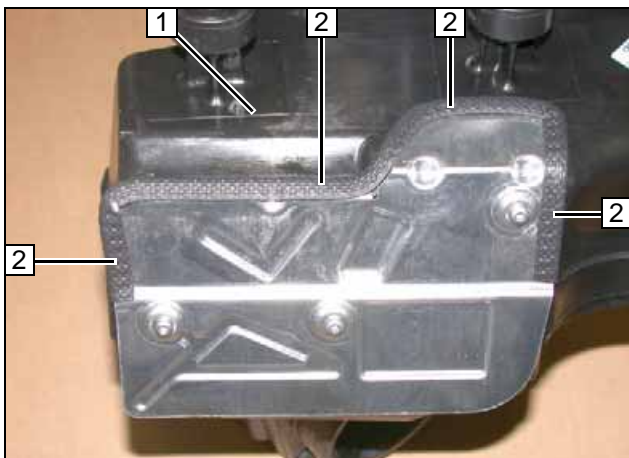

Install 300mm long edge protection 2 on air filter box 1.



Installing edge protection

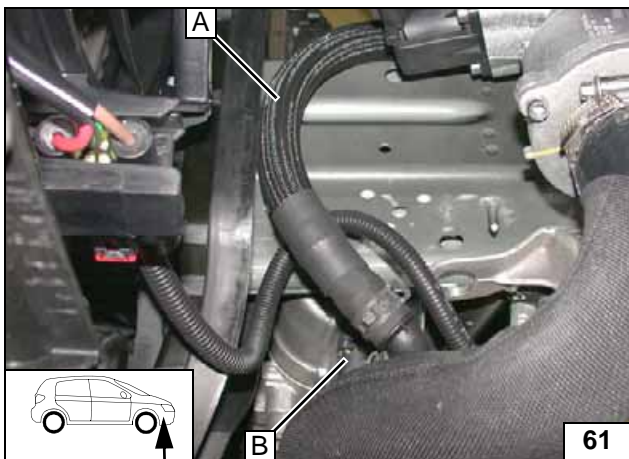

Connect hose A with hose B. Route the side without braided protection hose into the engine compartment.



Connection of heater inlet



Route hose A below premounted perforated bracket 1.



Routing in engine compartment

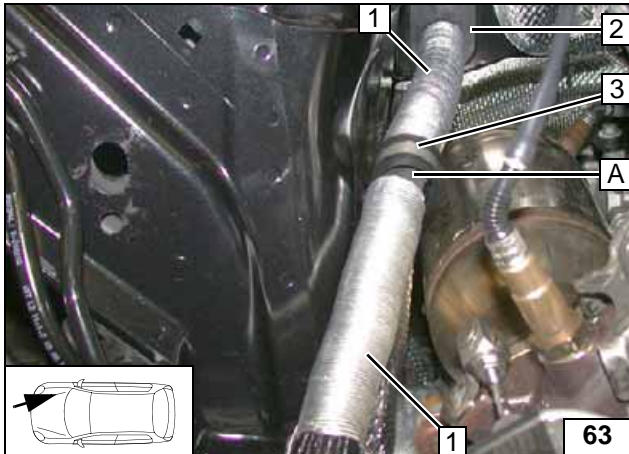

Route hose A through rubber-coated p-clamp **3** and grommet **2** up to the heat exchanger in the coolant reservoir.

1 200mm long heat protection hose [2x]



Routing in engine compartment

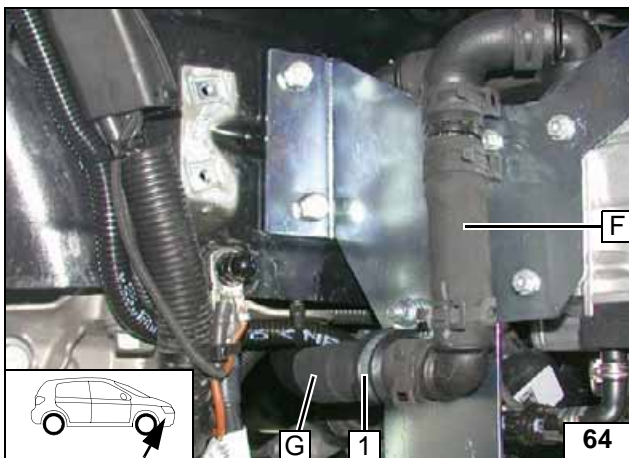

Route hose **G** through pre-mounted clamp **1** and connect it to hose **F**. Route the side without braided protection hose into the engine compartment.



Connection of heater outlet

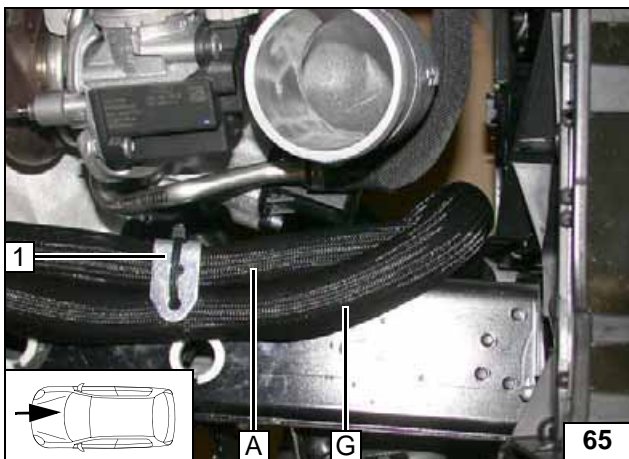

Fasten hoses to perforated bracket **1**.



Routing in engine compartment

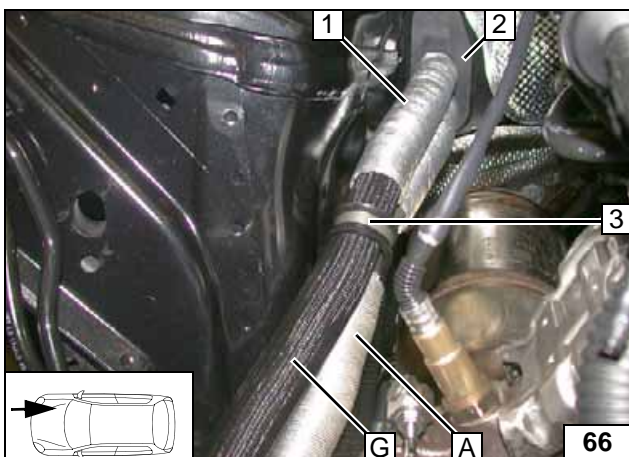

Route hose G through rubber-coated p-clamp **3** and grommet **2** up to the heat exchanger in the coolant reservoir.

1 200mm long heat protection hose

Routing in engine compartment

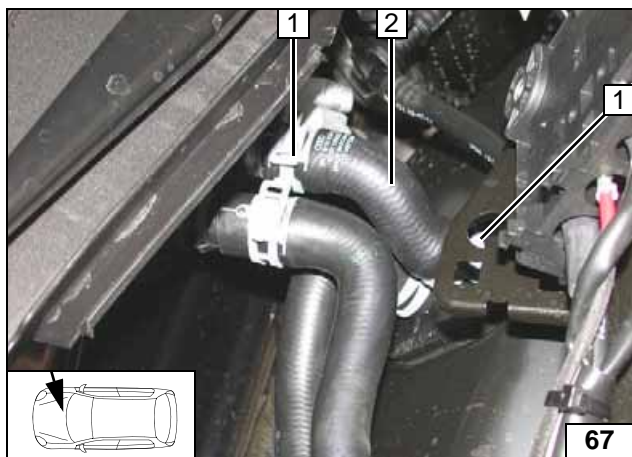

Vehicles with additional circulating pump

Remove and discard original vehicle hose 2. Original vehicle clamps [2x] 1 will be reused.



Cutting point

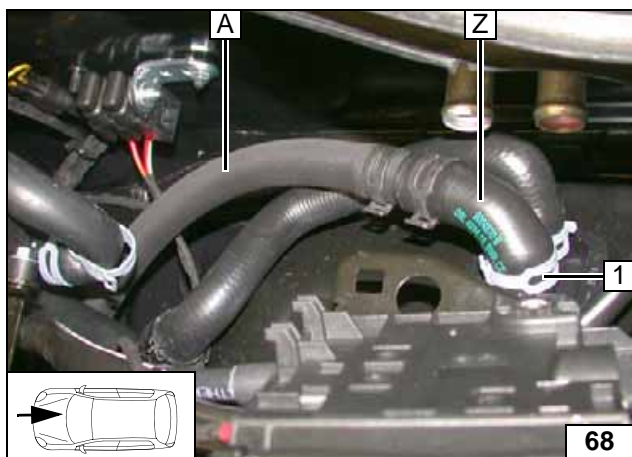

Hose of heat exchanger outlet removed to improve illustration.

1 Original vehicle clamp



Connecting engine outlet

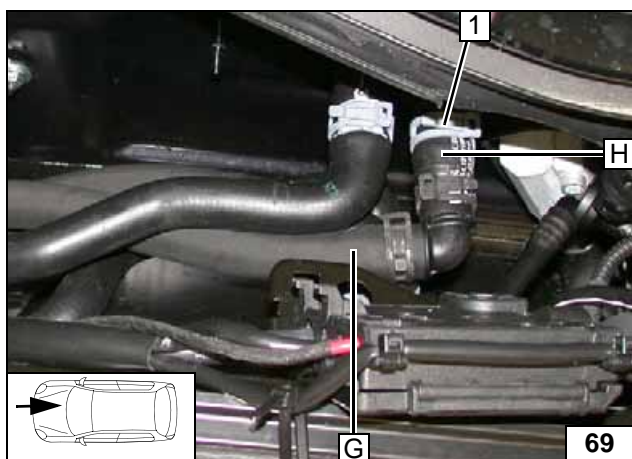

1 Original vehicle clamp

Connection of heat exchanger inlet

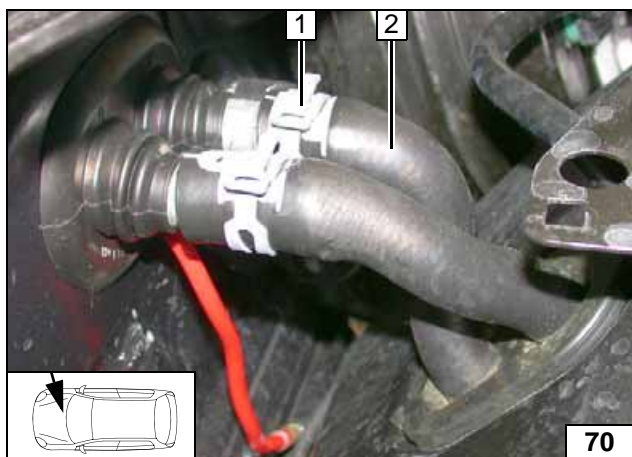

Vehicles without additional circulating pump

Remove original vehicle hose 2 from connection piece of heat exchanger inlet and turn to the right. Clamp 1 will be reused.



Cutting point

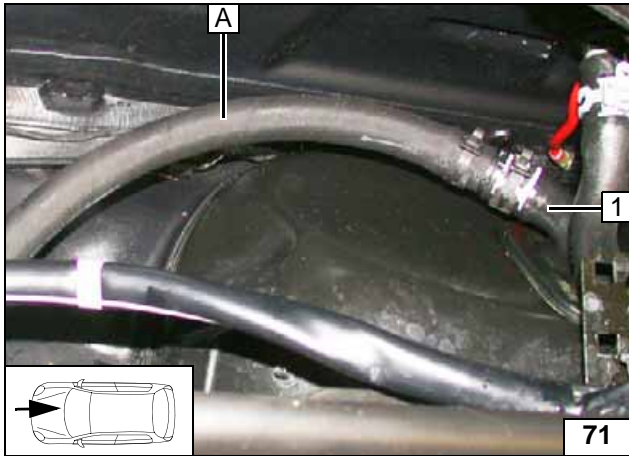

1 Engine outlet hose section turned

Connect-
ing engine
outlet

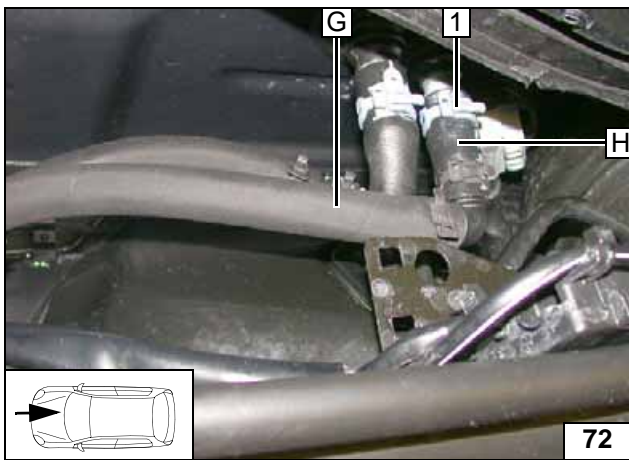

1 Original vehicle clamp



Conne-
tion of heat
exchanger
inlet

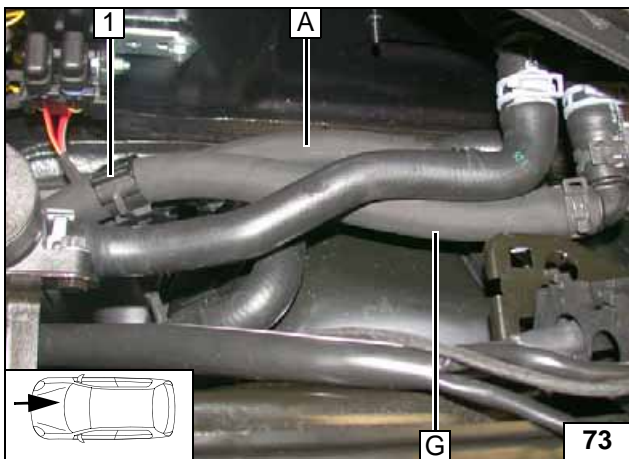

All vehicles

Figure shows vehicle with additional circulating pump. Align hoses. Ensure sufficient distance to neighbouring components, adjust, if necessary.

1 Hose bracket



Inserting
hose
bracket

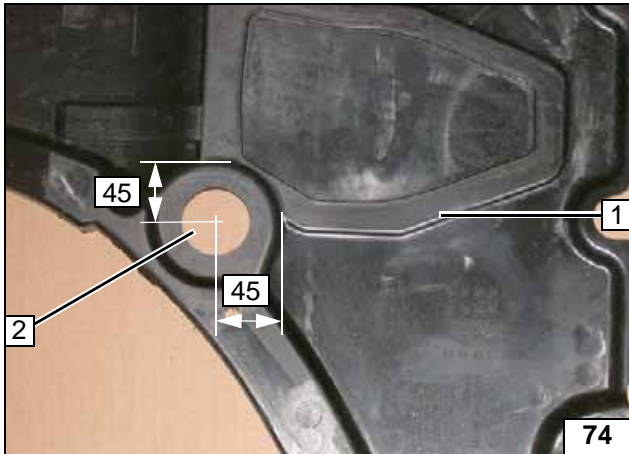
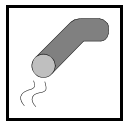

Exhaust Gas

Version 1

- 1 Underride protection, plastic
- 2 60mm dia. hole



**Cutting out
underride
protection**

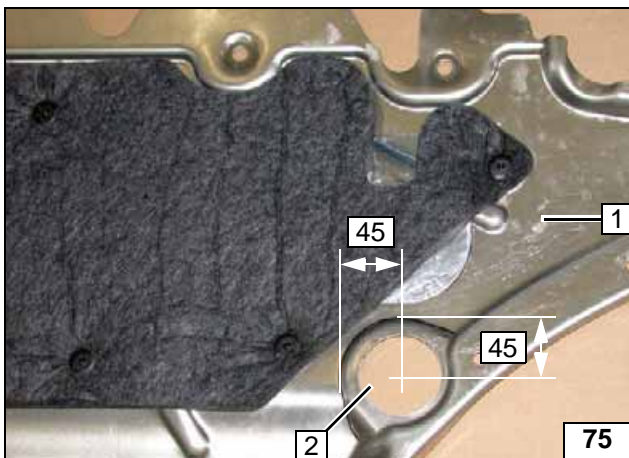

Version 2

- 1 Underride protection, aluminium
- 2 60mm dia. hole



**Cutting out
underride
protection**

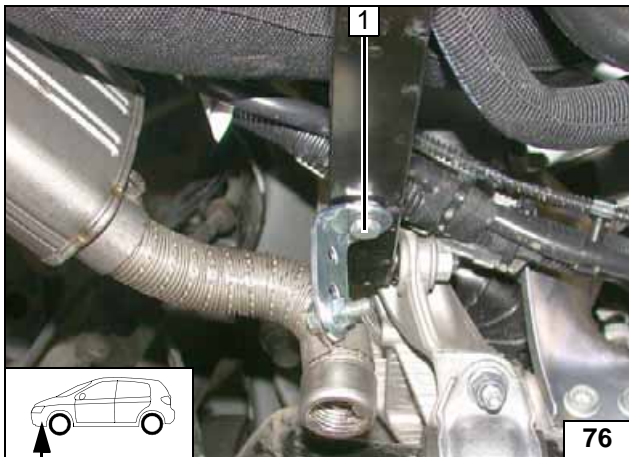

All vehicles

- 1 M6x20 bolt, spring lockwasher

**Installing
exhaust
end section**

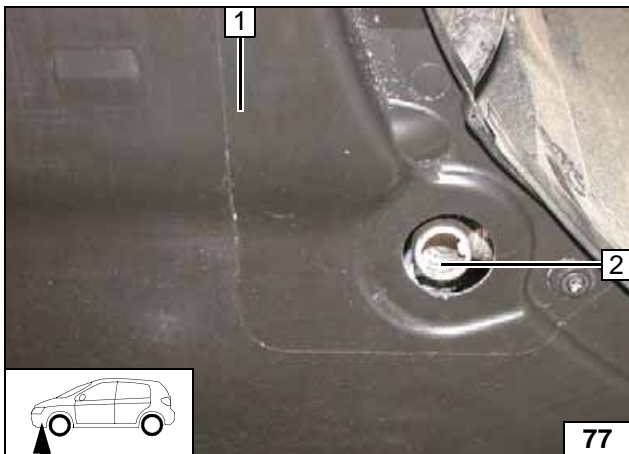
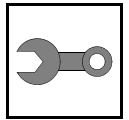

Figure shows vehicle with additional under-ride protection made of plastic. Ensure sufficient distance to neighbouring components, correct if necessary.



- 1 Mount underride protection
- 2 Centrally position exhaust end section in hole

**Aligning
exhaust
end section**



Final Work

WARNING!

Reassemble the disassembled components in reverse order. Check all hoses, clamps and all electrical connections for firm seating. Insulate all loose wires and tie back.

Only use manufacturer-approved coolant. Spray the heater components with anti-corrosion wax (Tectyl 100K, Order No. 111329).



- **Connect the battery.**
- **Fill and bleed the coolant circuit according to the vehicle manufacturer's specifications.**
- **Adjust digital timer, teach Telestart transmitter.**
- **Make settings on A/C control panel according to the "Operating Instructions for End Customer".**
- **Place instruction signboard "Switch off parking heater before refuelling" in the area of the filler neck.**
- **For initial start-up and function test, refer to installation instructions.**



Adaptation of Climatronic J255 Control Unit

in "Guided functions" mode with VAS 5051/52

Function:

- 08 Heating / Air-Conditioning
- 10 Adaptation

Set channel 17- value from "0" to "1"

Save



Operating Instructions for End Customer

Please remove this page in case of automatic air-conditioning and add it to the vehicle operating instructions.

Note:

We recommend matching the heating time to the driving time.

Heating time = driving time

Example:

For a driving time of approx. 20 min. (in one direction), we recommend not exceeding a switch-on time of 20 min.

Passenger compartment monitoring, if installed, must be deactivated in addition to the vehicle settings for the heating operation.

For information on deactivation, please see the vehicle owner's manual.

Before parking the vehicle, make the following settings:



- 1 Air outlet to windscreen
- 2 Set temperature on both sides to "HI".

2-Zone A/C control panel



- 1 Direct air outlet towards windscreen
- 2 Set temperature to "HI".

1-Zone A/C control panel

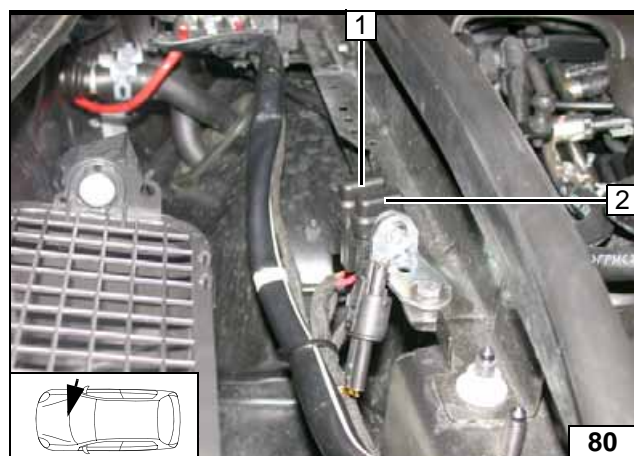

Audi A4 up to model year 2011

- 1 20A heater fuse F1
- 2 3A main fuse F2 of passenger compartment

Fuses of engine compartment



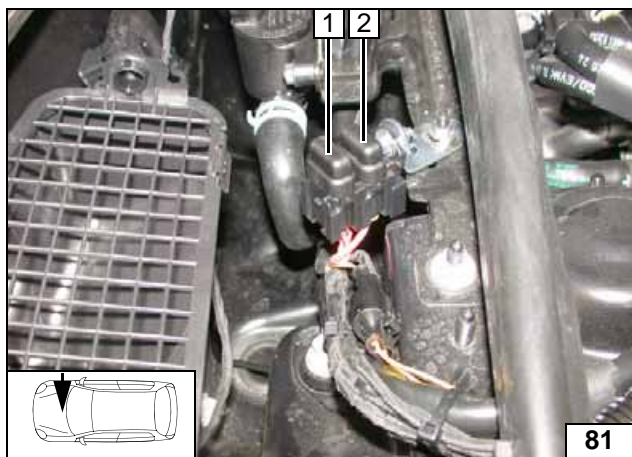

Audi A4 from model year 2012

- 1 20A heater fuse F1
- 2 3A main fuse F2 of passenger compartment

Fuses of engine compartment

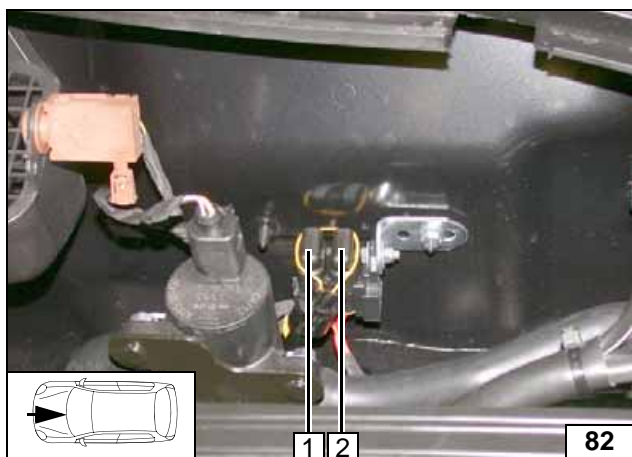

Audi A5 / A5 Cabrio

- 1 20A heater fuse F1
- 2 3A main fuse F2 of passenger compartment

Fuses of engine compartment

