

# Water Heater Unit



**Thermo Top E Additional Heater** e1 00 0003

**Thermo Top C Additional Heater** e1 00 0002

**Thermo Top P Additional Heater** e1 00 0104

## Installation Instructions

### Citroen C6 2.2 I HDI

Diesel

from Model Year 2006

Left-hand drive vehicle



#### **WARNING!**

Hazard warning:

Incorrect installation or repair of Webasto heating systems may cause a fire or result in the emission of carbon monoxide, which can be fatal. Serious or fatal injuries can be caused as a result.

Specialist company training, technical documentation, specialized tools and equipment are required to install and repair Webasto heating and cooling systems.

NEVER attempt to install or repair Webasto heating or cooling systems if you have not successfully completed the company training and thereby acquired the required technical skills, or if you do not have access to the required technical documentation, tools and equipment needed to carry out correct installation and repairs.

ALWAYS follow all Webasto installation and repair instructions and observe all warnings.

Webasto does not accept any liability for defects and damage that are attributable to installation by untrained staff.

**Table of Contents**

Validity	2	Preparing heater unit and bracket	12
Heater Unit/Installation Kit	3	Preparing installation location	12
Foreword	3	Installing heater unit	14
General Instructions	3	Coolant connection	15
Special Tools	3	Fuel Connection	19
Explanatory Notes on Document	4	Exhaust system	22
Preliminary Work	5	Combustion air	23
Heater unit installation location	5	Final Work	24
Preparing electrical system	6	Operating Instructions for End Customer	25
Electrical Connections	7	Template for Fuel Standpipe	26
Fan controller	8		
Remote option (Telestart)	10		
Remote option (Thermo Call)	11		

**Validity**

Manufacturer	Model	Type	EG-BE No./ABE
Citroen	C6 2.2 I HDI		e1 * 2001/116 * 0320

Engine type	Engine model	Output in kW	Displacement in cm <sup>3</sup>
4HT	Diesel	125	2179

Vehicle and engine types, equipment variants and national specifications not listed in these installation instructions have not been tested. However, installation according to these installation instructions may be possible.

The installation location of a digital timer and summer/winter switch should be confirmed with the end customer before installation.

**Heater Unit/Installation Kit**

Quantity	Description	Order No.:
1	Retail accessories with desired heater control	See price list
1	Installation kit for Citroen C6 2.2 I HDI Diesel	1310783B

**Heater unit recommended for the respective vehicle class:**

Vehicle	Heater unit
Compact car	Thermo Top E
Mid-size car, station wagon	Thermo Top C
Full-size car, van, offroader	Thermo Top P

The selection of the heater unit is based on the passenger compartment size of the vehicle and the level of comfort required by the customer!



**Foreword**

These installation instructions apply to Citroen C6 2.2 I HDI Diesel vehicles - for validity, see page 2 - from model year 2006 and later, assuming technical modifications to the vehicle do not affect installation, any liability claims excluded. Depending on the vehicle version and equipment, modifications may be necessary during installation with respect to these installation instructions.

However, the stipulations in the "installation instructions" and "operating and maintenance instructions" for the *Thermo Top C/P/E* must always be observed.

The corresponding rules of technology and any information from the vehicle manufacturer should be observed during the installation work.

**General Instructions**

Installation should be carried out according to the general, standard rules of technology. Unless specified otherwise, fasten hoses, lines and wiring harnesses to original vehicle lines and wiring harnesses using cable ties.

Sharp edges should be fitted with edge protectors (split-open plastic hose).

Spray unfinished body areas, e.g. drilled holes, with anti-corrosion wax (Tectyl 100K, Order No. 111329).

**Special Tools**

- Torque wrench for 2.0 - 10 Nm
- Hose clamping pliers
- Metric thread-setter kit

**Explanatory Notes on Document**

To provide you with a quick overview of the individual working steps, you will find an identification mark on the outside top right corner of the page in question.

**Mechanical system**

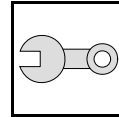

**Electrical system**

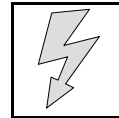

**Coolant connection**

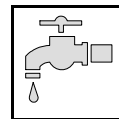

**Fuel connection**

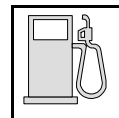

**Exhaust system**

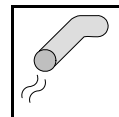

**Combustion air**

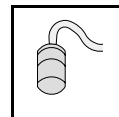

Special features are highlighted using the following symbols:



Specific risk of injury or fatal accidents.



Specific risk of damage to components.



Specific risk of fire or explosion.



Reference to general installation instructions of Webasto components or to the manufacturer's vehicle-specific documents.



Reference to a special technical feature.

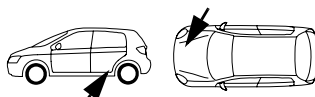

The arrow in the vehicle icon indicates the position on the vehicle and the viewing angle.

**Preliminary Work**

**WARNING!**

- Depressurize the cooling system.
- Copy the factory number from the original type label to the duplicate type label.
- Remove years that do not apply from the duplicate label.
- Attach the duplicate label (type label) in the appropriate place.
- Move right-hand rear seat toward front and remove (3 bolts)
- Open the right-hand fuel sender service lid.
- Remove the fuel-tank sending unit in accordance with the manufacturers specifications.
- Disconnect and completely remove the battery.
- Remove the cover of the central electrical box in the engine compartment.
- Detach the control units in the central electrical box
- Remove the air filter together with the intake hose.
- Open the fuel tank cap, ventilate the tank.
- Close the tank cap again.
- Remove the front underride protection.
- Remove the rear right underride protection.
- Remove the bumper.
- Remove the left-hand headlight
- Remove the left-hand wheel well trim
- Remove the center section of the rear seat bench (unclip).
- Remove the left-hand instrument panel trim.
- Remove the A/C control panel according to the manufacturer's specifications.

Remove page 25 "Operating Instructions for End Customer" and add to the vehicle operating instructions.

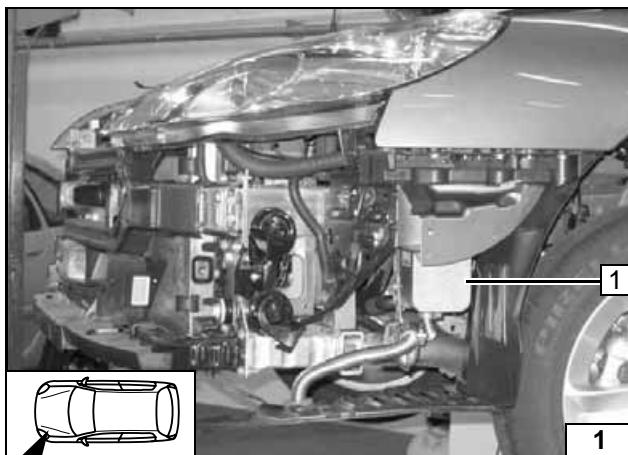

**Heater unit installation location**

- 1 Heater unit

**Installation location**



**Preparing electrical system**

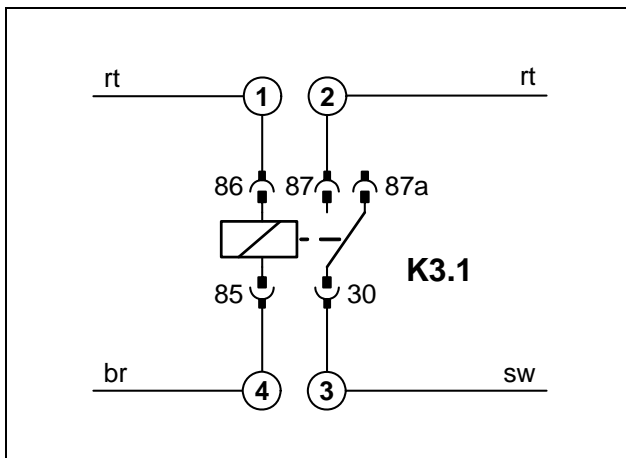
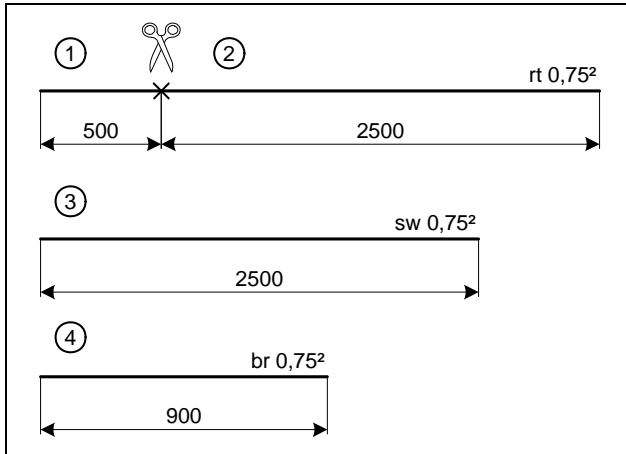

Produce connections as shown in wiring diagram. Install wire section 2 and 3 in protective sleeving.



**Cutting wires to length**

**Preparing additional relay K3.1**

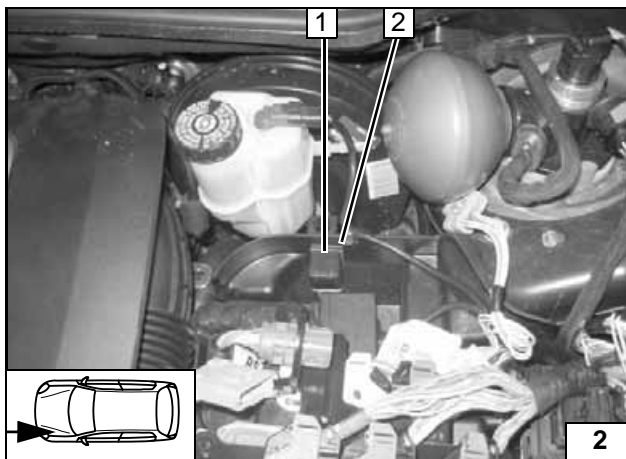

Cut mounting tab off K3.1 relay 1 and fasten with Velcro strip 2 on housing of central electrical box.



**Installing K3.1**

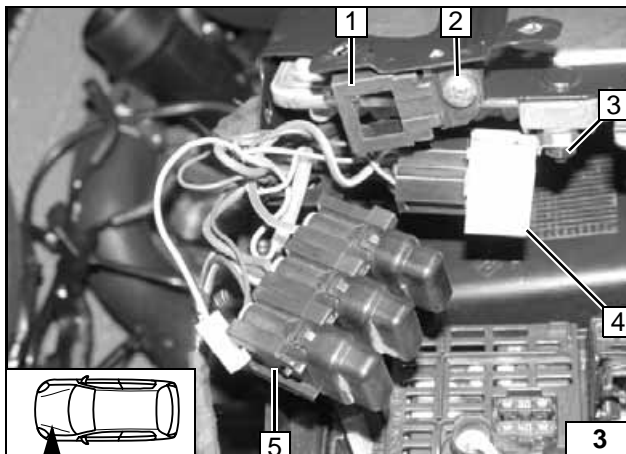

Drill out mounting tab of K3 relay 4 to 6 mm dia.

- 1 Retaining plate for fuse holder
- 2 4 mm dia. hole, 5.5x9.5 self-tapping screw
- 3 M6 flanged nut on original vehicle bolt
- 5 Fuse holder



**Installing K3 and fuse holder**



### Electrical Connections

#### Fuse holder, relay K3

- 1 K3 relay
- 2 Fuse holder

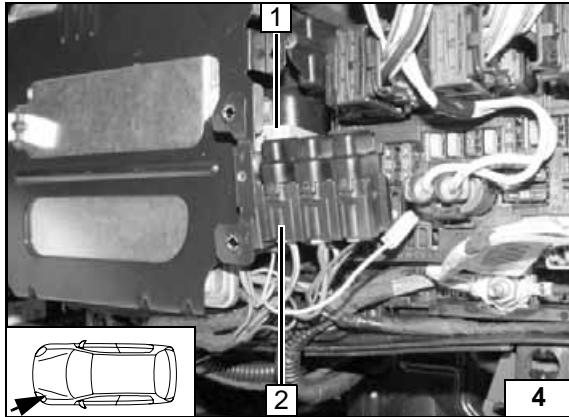

#### Digital timer and summer/winter switch option

- 1 Digital timer
- 2 Summer/winter switch, drilled hole 12 mm dia.

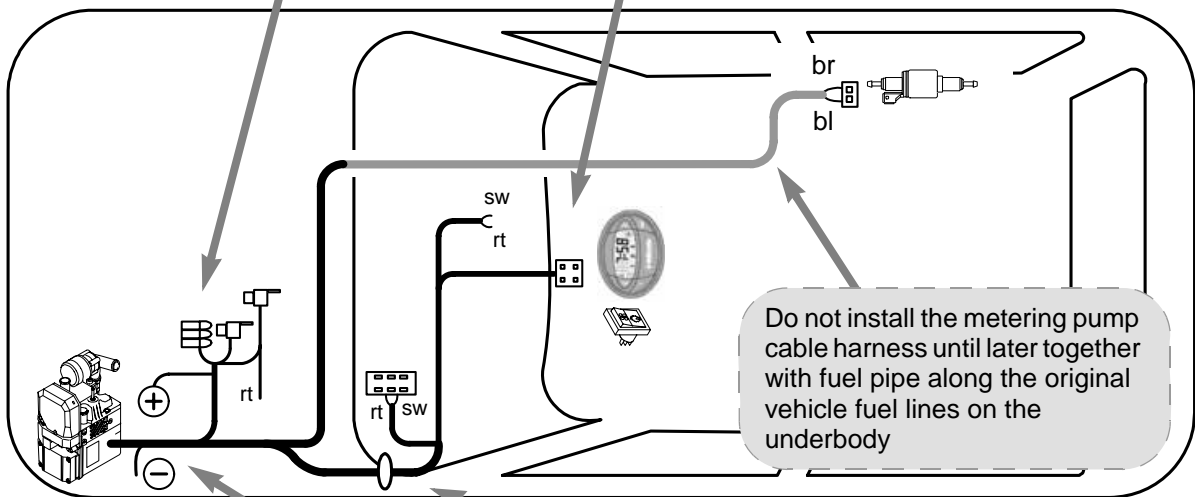
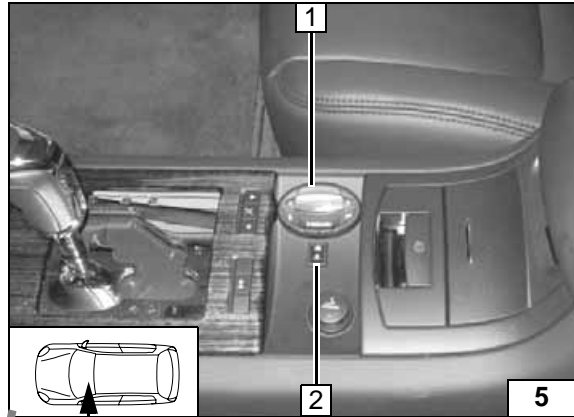

Wiring harness installation diagram

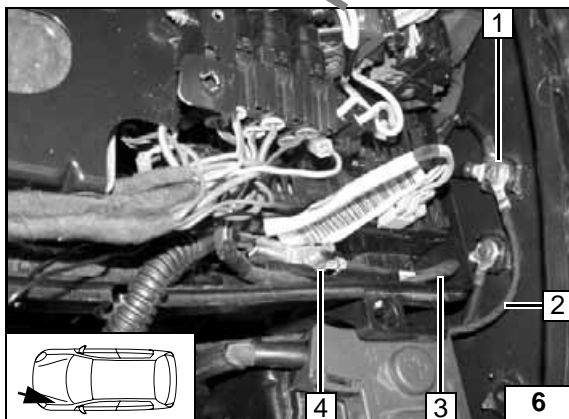

#### Positive and ground connection

- 1 Original vehicle ground support point
- 2 Ground wire
- 3 Positive wire
- 4 Original vehicle positive support point

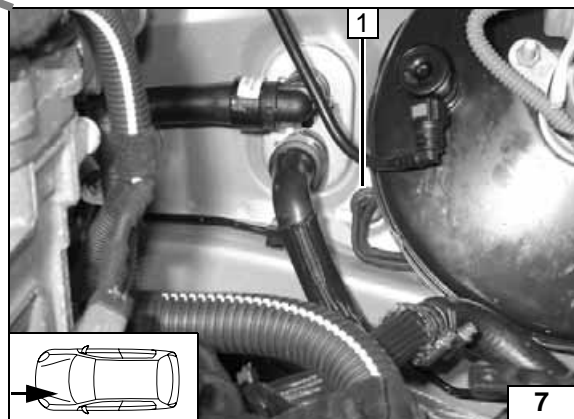

#### Wiring harness pass through

- 1 Protective rubber plug



Fan controller

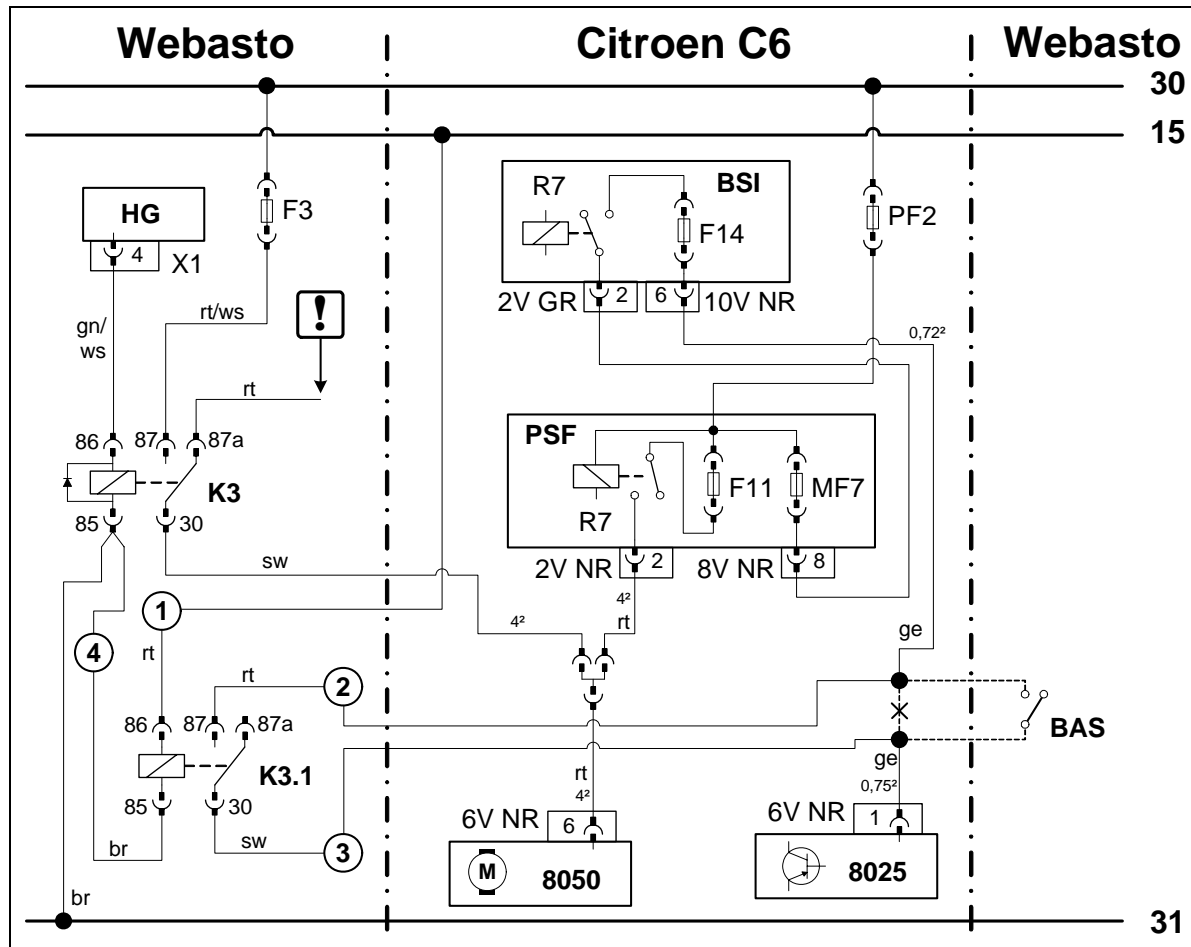

Wiring diagram

Webasto components		Citroen components		Colors and symbols	
HG	Heater unit TT-C/E	8050	Fan motor	rt	red
X1	6-pin heater unit connector	8025	Air-conditioning control element	ws	white
F3	Fuse, 25 A	PSF	Main power supply	sw	black
K3	Fan relay	BSI	Central switching unit	br	brown
K3.1	Additional relay	6V NR	6-pin connector	gn	green
BAS	Operating mode switch option	2V NR	2-pin connector	ge	yellow
		2V GR	2-pin connector	!	Insulate wire end and tie back
		8V NR	8-pin connector	X	Cutting point
		10V NR	10-pin connector		
		PF2	Main fuse		

Legend

Note!

The operating mode switch (OMS) option is used to switch over the A/C control unit into the standard or heating mode.  
 If the heating mode is desired, the switch (OMS) must be set to the "Heat" symbol.  
 In the standard mode, the changing of the flap control and the resetting of the control unit is prevented.

The installation location of the operating mode switch must be coordinated with the end customer prior to installation.





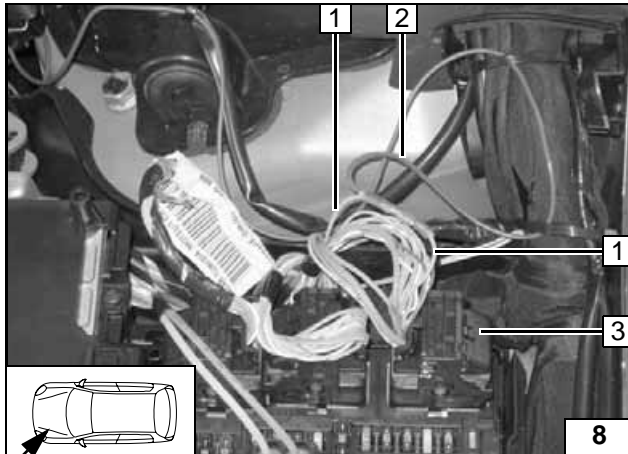
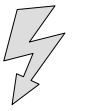

Measure out directly switched terminal 15 without switch-off delay on connector 28V GR 3. Connector assignment may vary. Produce connections as shown in wiring diagram.

- 1 Yellow (ge) wire of terminal 15 [2x]
- 2 Red (rt) wire from K3.1/86

**Con-  
necting  
central  
electrical  
box**

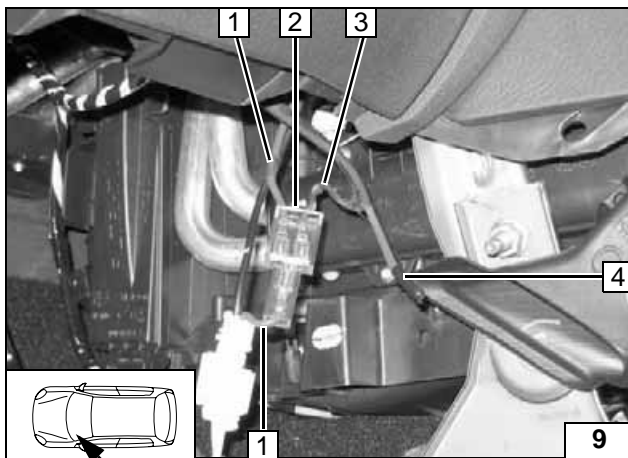

Produce connections as shown in wiring diagram.

- 1 Red (rt) wire to fan motor [2x]
- 2 3x distributor
- 3 Black (sw) wire from K3/30
- 4 Isolate red (rt) wire and tie back

**Con-  
necting fan  
motor**

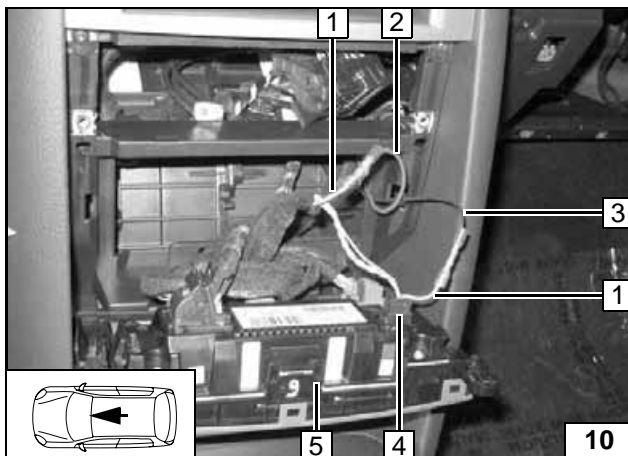

Connection on 6-pin connector 6V NR 4 from A/C control panel 5.

Produce connections as shown in wiring diagram.

- 1 Yellow (ge) wire [2x]
- 2 Red (rt) wire from K3.1/87
- 3 Black (sw) wire from K3.1/30

**Con-  
necting  
A/C control  
panel**



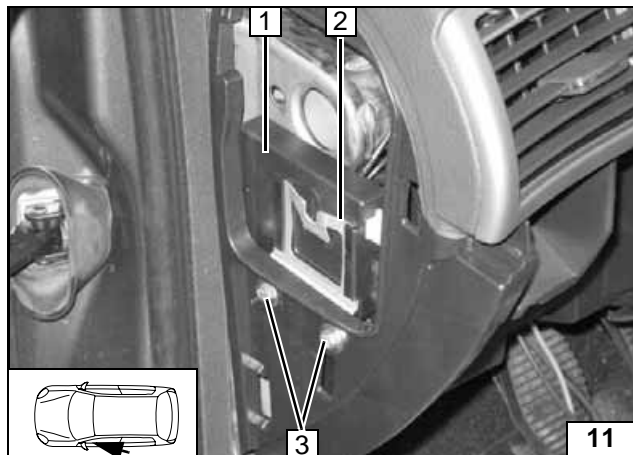

**Remote option (Telestart)**

- 1 Receiver
- 2 Bracket
- 3 5.5 mm dia. hole, M5x12 bolts, M5 flanged nuts [2x each]



**Installing receiver**

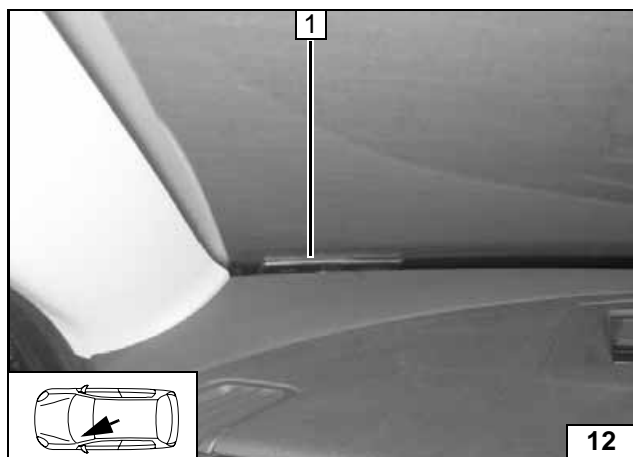

- 1 Antenna

**Installing antenna**

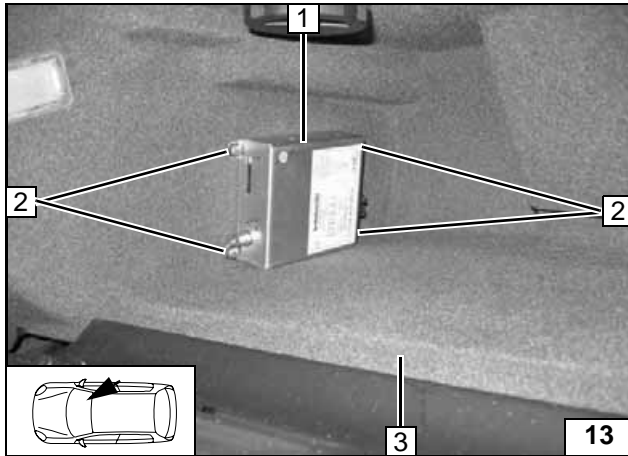

**Remote option (Thermo Call)**

- 1 Receiver
- 2 M 5.5x13 self-tapping screws [4x]
- 3 Glove compartment



**Installing receiver**

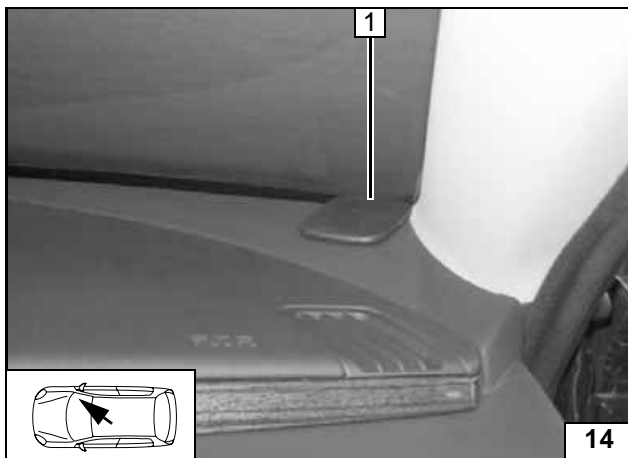

- 1 Antenna

**Installing antenna**

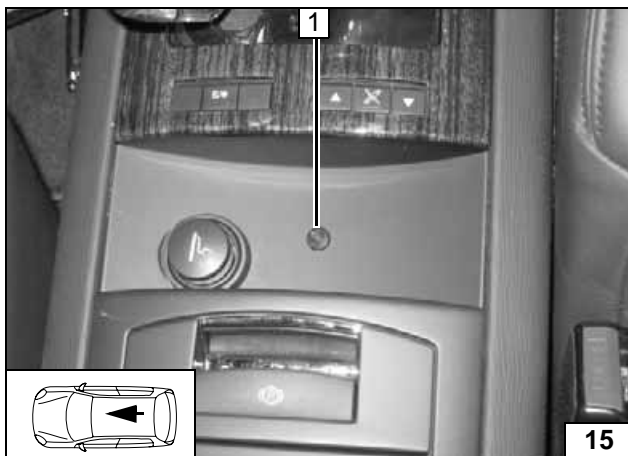

- 1 Pushbutton

**Installing push button**

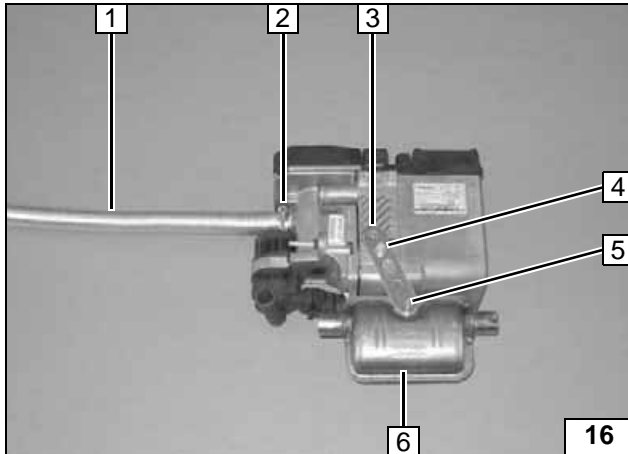
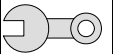

**Preparing heater unit and bracket**



Tighten EJOT screws to 10 Nm!

- 1 Combustion-air intake pipe
- 2 27 mm dia. hose clamp
- 3 Perforated bracket
- 4 Ejet screw
- 5 M6x20 bolt, flanged nut
- 6 Exhaust muffler

**Preassem-  
bling  
heater unit**

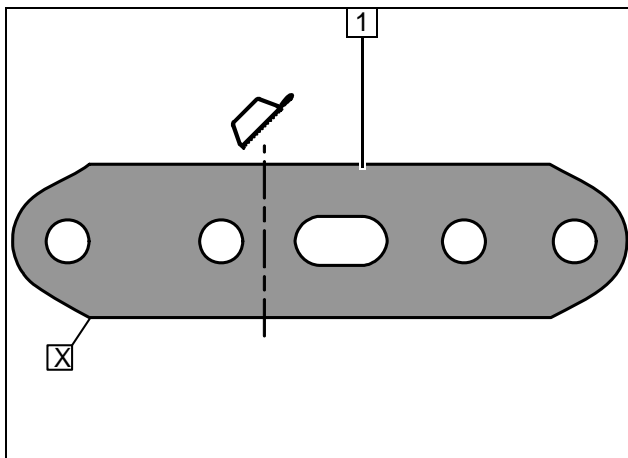

1 Shorten perforated bracket

Discard section X

**Preparing  
perforated  
bracket**

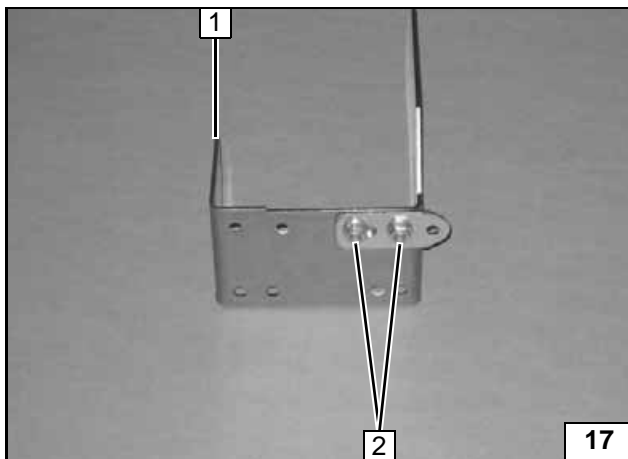

- 1 Bracket
- 2 M6x12 bolt, flanged nut [2x each]

**Preassem-  
bling  
bracket**

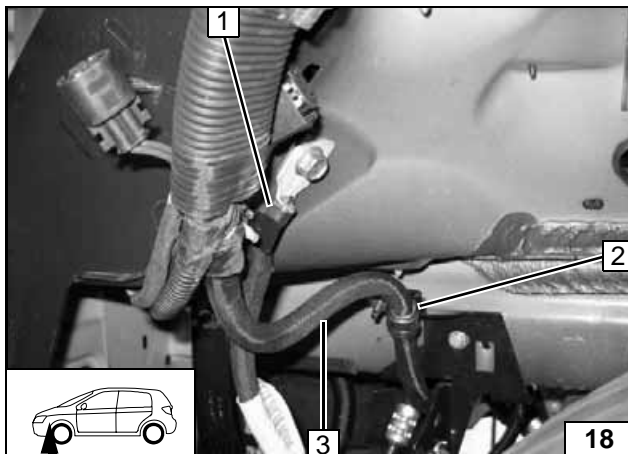

**Preparing installation location**

- 1 Ground wire
- 2 Rubber-coated p-clamp turned 180°
- 3 Positive wire

**Changing  
line routing**

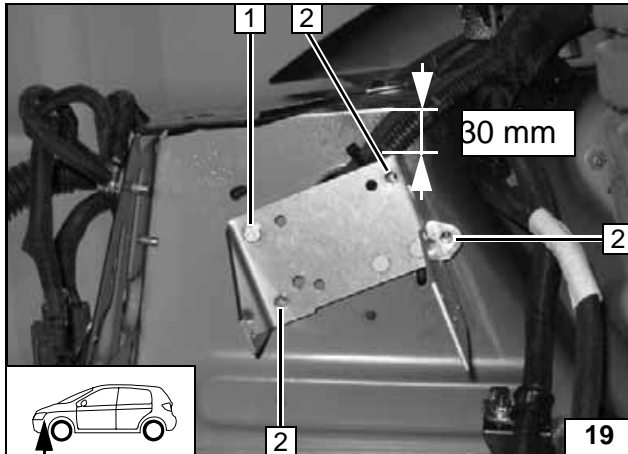
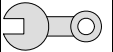

Loosely install bracket and align.

- 1 Original vehicle hole, M6x35 bolt, 20 mm shim, M6 flanged nut
- 2 Copy hole pattern [3x]



Copying hole pattern

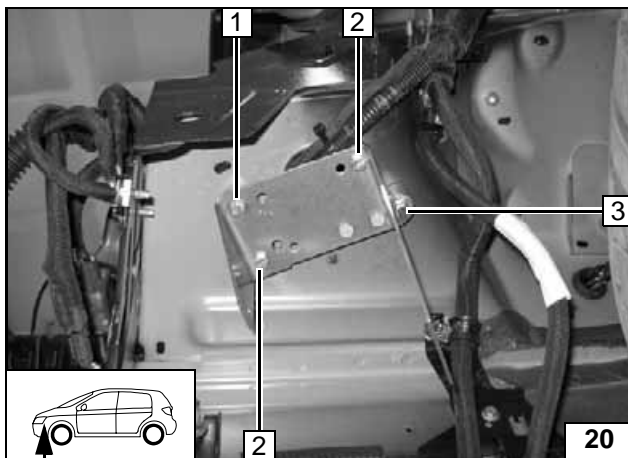

When drilling, watch components located behind!

- 1 Original vehicle hole, M6x35 bolt, 20 mm shim, M6 flanged nut
- 2 7 mm dia. hole, M6x35 bolt, 20 mm shim, M6 flanged nut [2x each]
- 3 9.1 mm dia. hole, M6 rivet nut, M6x35 bolt, spring lockwasher, 20 mm shim



Installing bracket

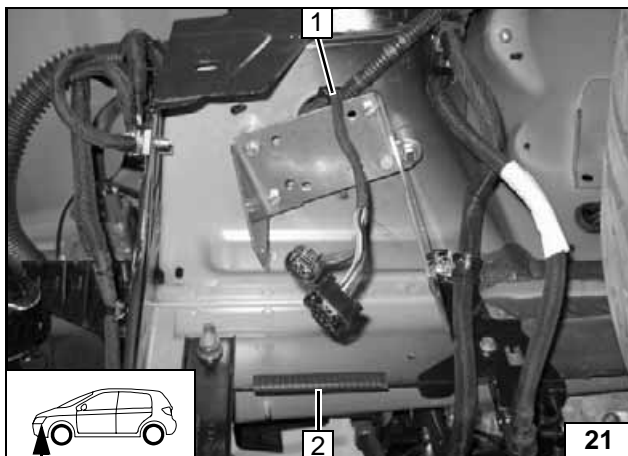

- 1 Wiring harness of heater unit
- 2 Edge protection

Installing edge protection

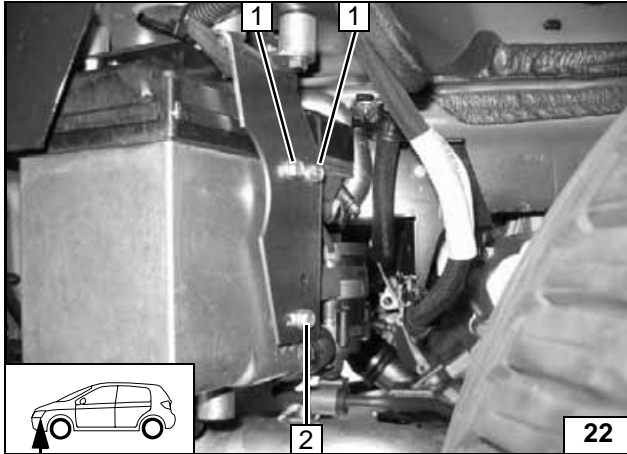
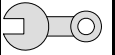

**Installing heater unit**

Connect wiring harness for heater unit before installation. Insert two washers between heater unit and bracket at position **2**.

- 1 E-jot screw [2x]
- 2 E-jot screw



**Installing heater unit**

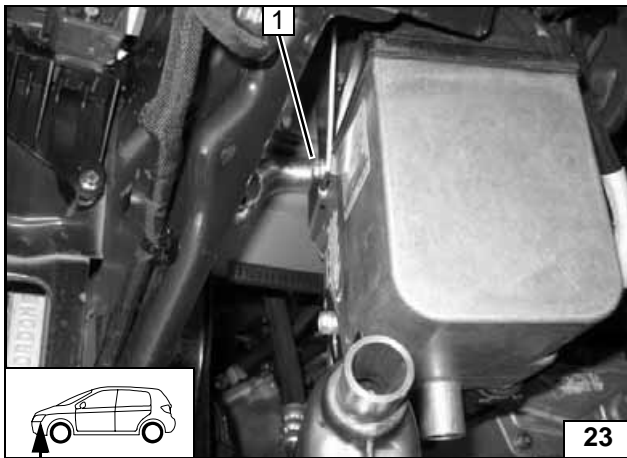

- 1 E-jot screw

**Installing bracket**



**Coolant connection**

**WARNING!**

Tighten all hose clamps to 2.0 + 0.5 Nm. Any coolant running off should be collected using an appropriate container. Install hoses so that they are kink-free. Unless specified otherwise, always fasten using cable ties. Position hose clamps and spring band clamps so that no other hose can be damaged. When installing the coolant hose, the heater unit must be filled with coolant. The connection should be "inline" based on the following diagram:

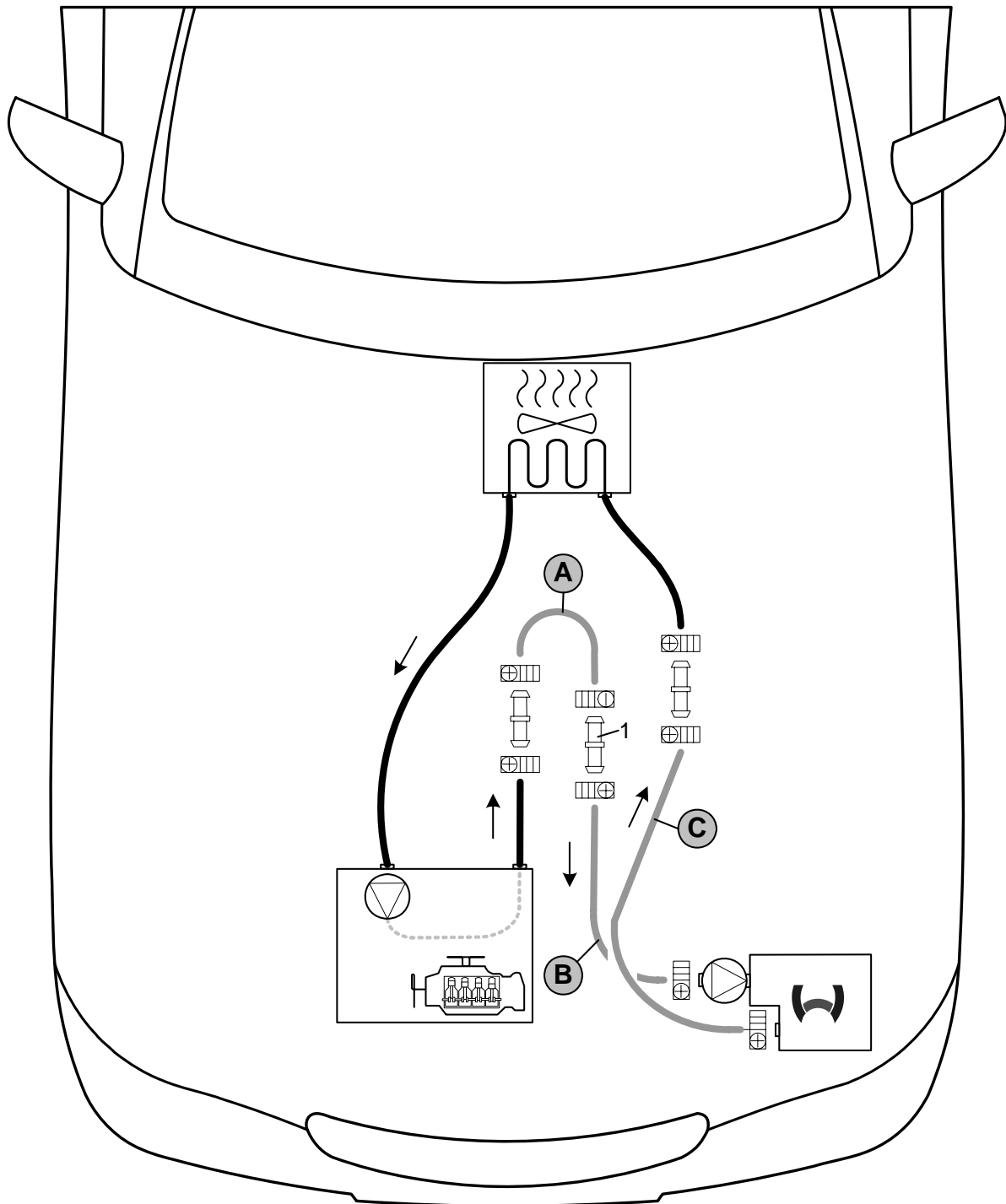

Coolant routing diagram

All connecting pipes without a specific designation = dia. 18x20. All hose clamps  = 20-27 mm dia.!  
 1 = Connecting pipe = dia. 20x20



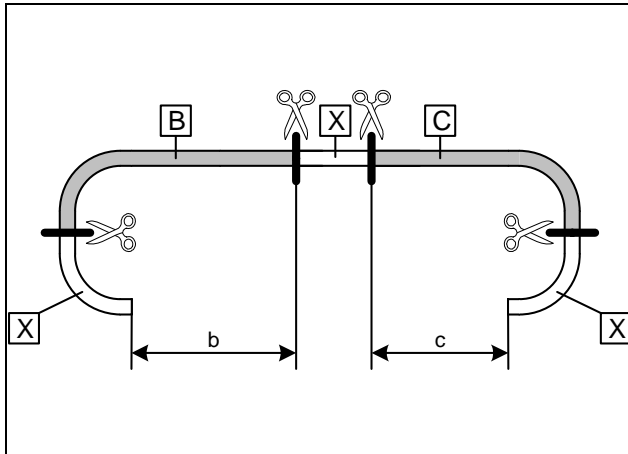

b = 640 mm  
c = 800 mm

Discard section X

Cutting coolant hoses to length

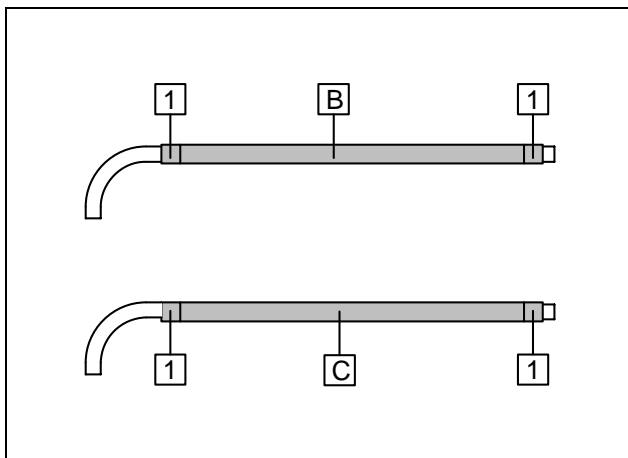

Push braided protection hoses onto hose B and C and cut to length.  
Cut heat shrink plastic tubing to length.



1 25 mm heat shrink plastic tubing [4x]

Preparing coolant hoses

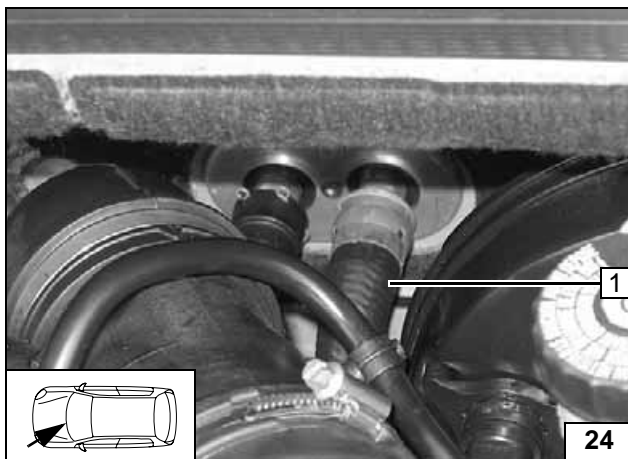

1 Remove original vehicle hose from engine outlet to heat exchanger inlet

Preparing coolant

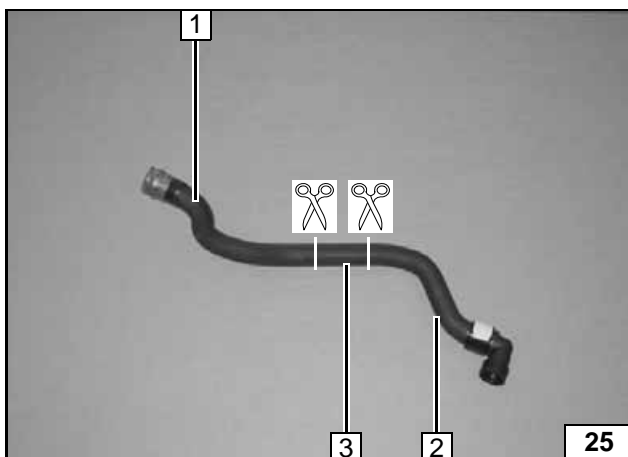

1 Hose section of heat exchanger inlet  
2 Hose section on engine outlet  
3 Discard section

Cutting point



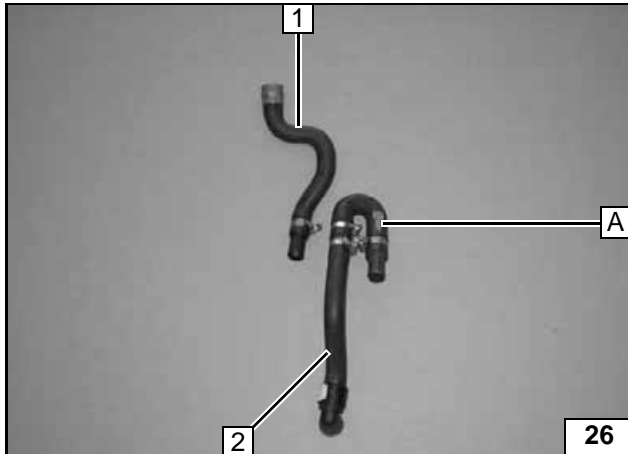

- 1 Hose section of heat exchanger inlet
- 2 Hose section on engine outlet

Preparing coolant hoses

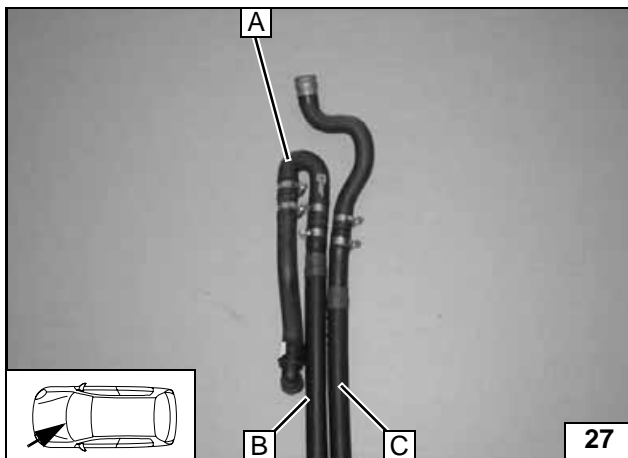

- 1 Black (sw) rubber profile [2x]
- 2 Spacer bracket
- 3 Cable tie

Preparing coolant hoses

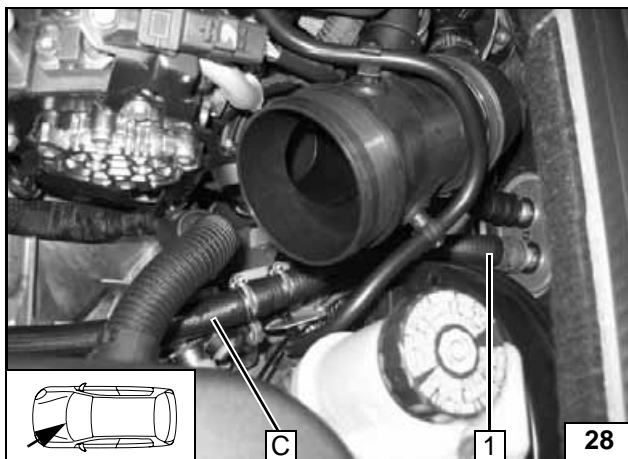

- 1 Heat exchanger inlet

Con-  
nection on  
heat  
exchanger  
inlet

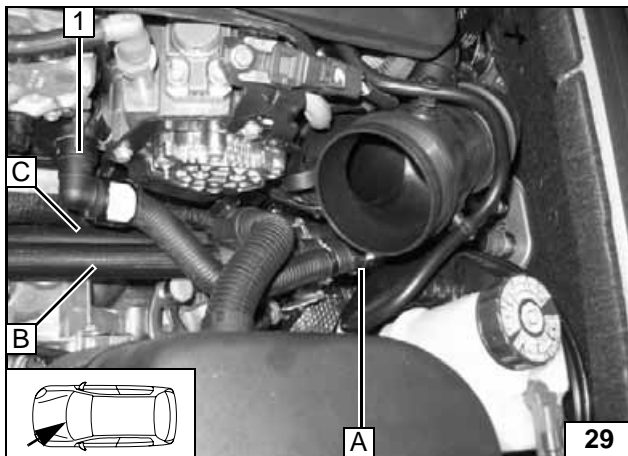

- 1 Engine outlet

Con-  
nection on  
engine  
outlet

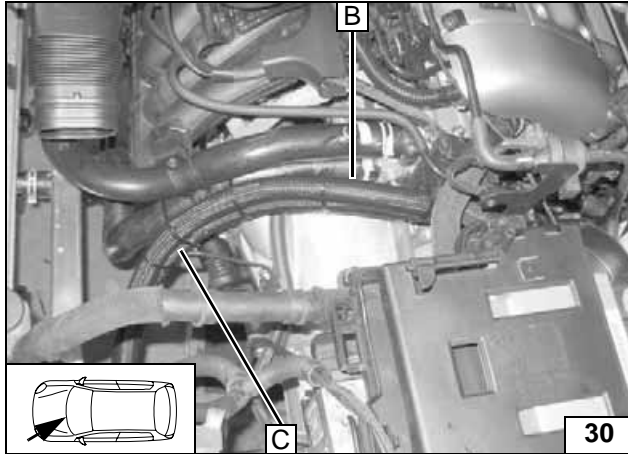

Fasten coolant hoses with cable ties.



Routing in engine compartment

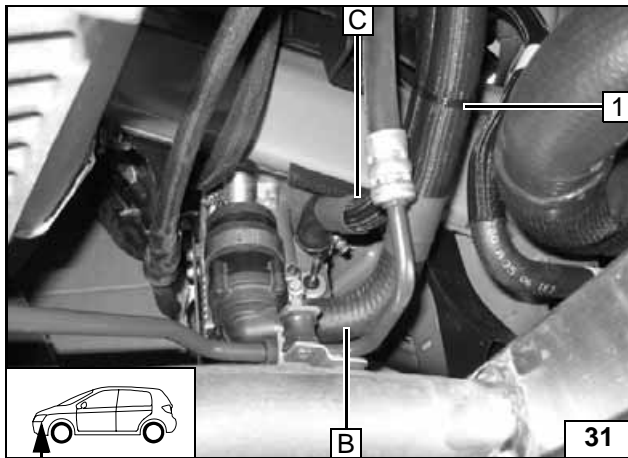

1 Cable tie

Con-  
nection to  
heater unit



**Fuel Connection**

**CAUTION!**

Open the vehicle's fuel tank cap, ventilate the tank and then re-close the tank lock.

Catch any fuel running off with an appropriate container.

Install fuel line and metering-pump wiring harness so that they are protected against stone impact. Unless specified otherwise, always fasten using cable ties.

Mount the fuel line and wiring harness with rub protection on sharp edges.

**WARNING!**

The fuel line and wiring harness are routed to the metering pump in as shown in the wiring harness routing diagram.

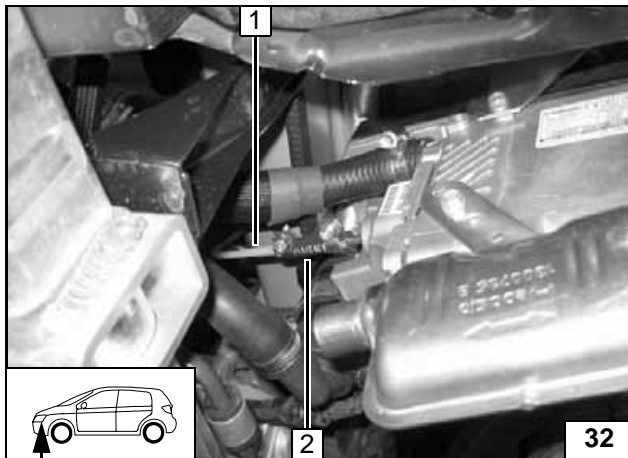

- 1 Fuel line
- 2 Hose section, 10 mm dia. hose clamp [2x]

**Con-  
nection to  
heater unit**

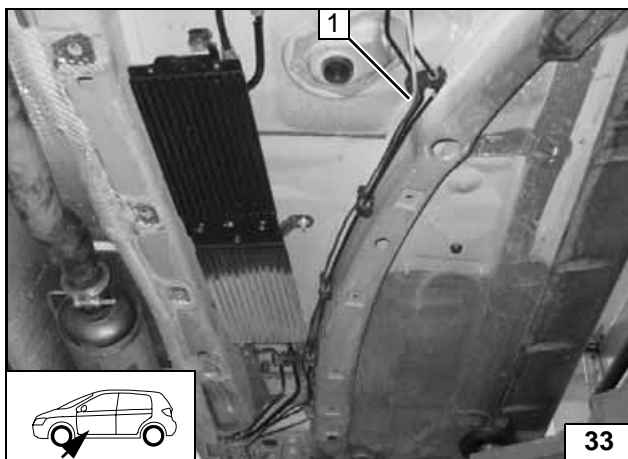

- 1 Fuel line, wiring harness of metering pump on original vehicle brake lines

**Installing  
lines**

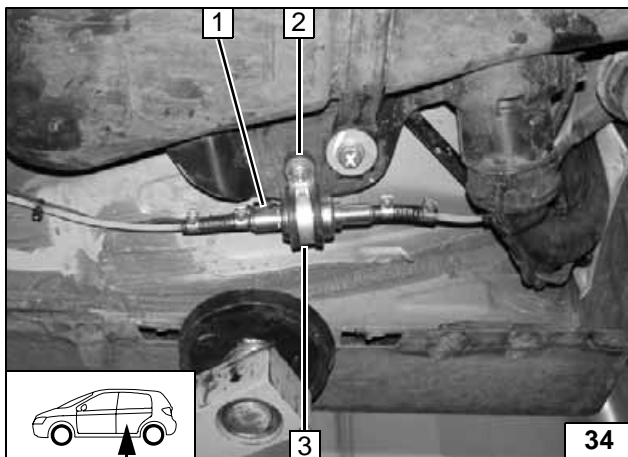

Ensure proper installation position of metering pump, see "Installation Instructions".  
Installation location on right next to vehicle fuel tank.

- 1 Metering pump
- 2 Silent block, large diameter washer, flanged nut [2x], on original vehicle hole
- 3 Rubber-coated pipe clamp



**Installation  
location of  
metering  
pump**

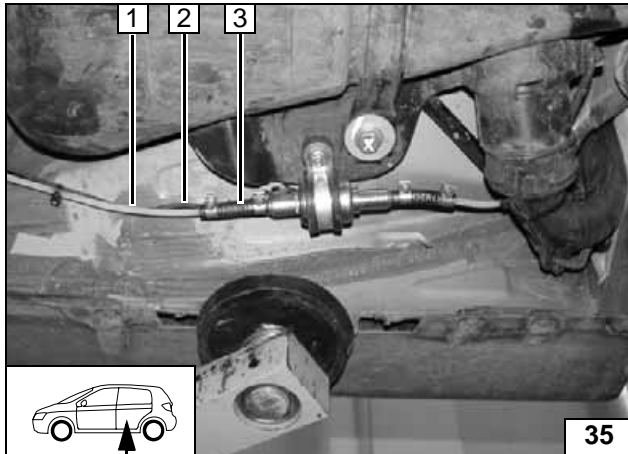

Fuel line 1 from heater unit on pressure side of metering pump [side with connector]. Check the position of the components; adjust if necessary. Check that they have free clearance.

- 2 Wiring harness of metering pump, connector mounted
- 3 Hose section, 10 mm dia. hose clamp [2x]



**Con-necting to metering pump**

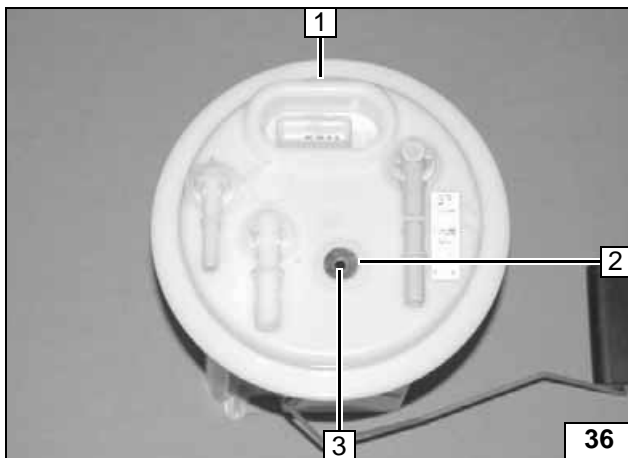

Remove and dismantle fuel-tank sending unit 1 according to manufacturer's instructions.

- 2 5 mm dia. large diameter washer
- 3 Copy hole pattern, 6 mm dia. hole



**Removing fuel**

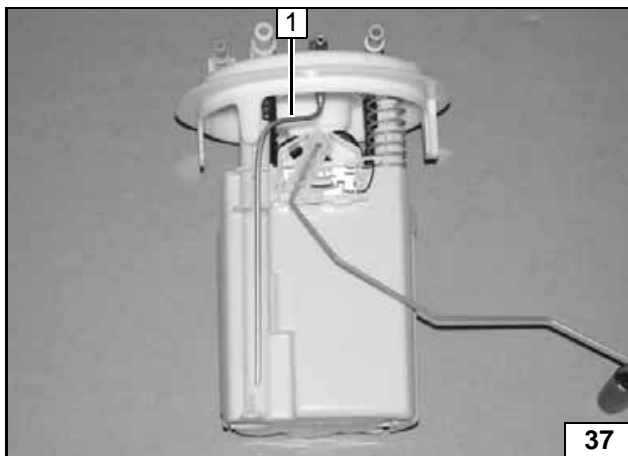

Shape fuel standpipe 1 according to template, cut to length and install, see "installation instructions".



**Installing fuel standpipe**

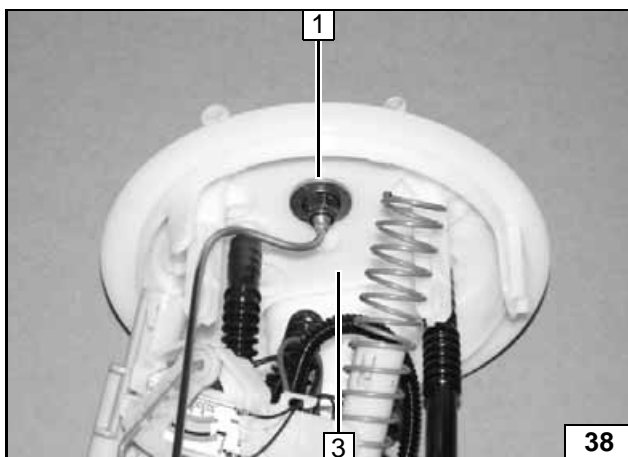

Position large diameter washer 1 between flanged nut and cover of fuel-tank sending unit!



**Installing fuel standpipe**

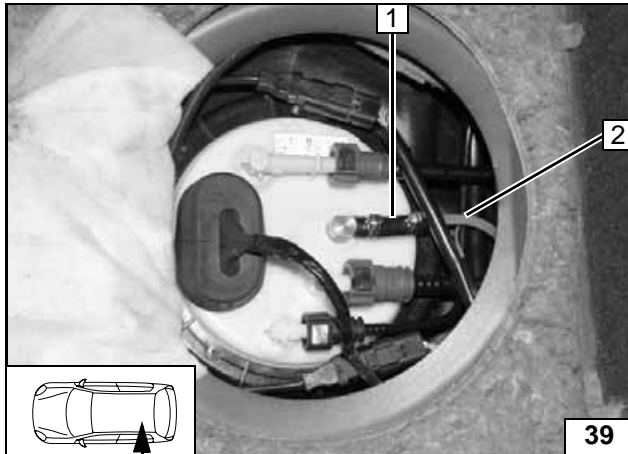

Install fuel-tank sending unit according to manufacturer's specifications.  
 1 Hose section, 10 mm dia. hose clamp [2x]  
 2 Fuel line



**Con-necting fuel line**

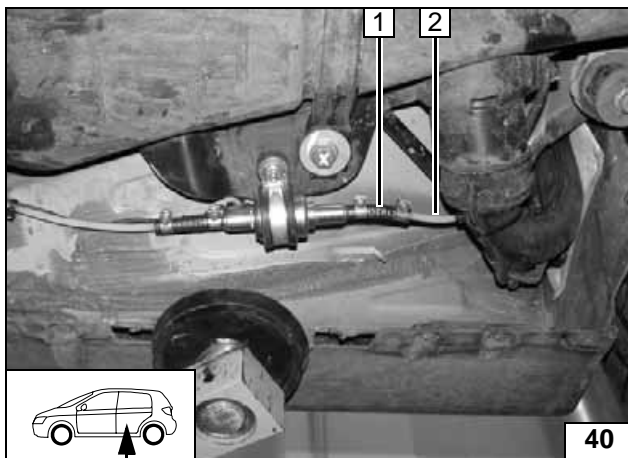

Fuel line 2 from fuel standpipe on intake side of metering pump [side without connector]. Check the position of the components; adjust if necessary. Check that they have free clearance.

1 Hose section, 10 mm dia. hose clamp [2x]



**Con-necting to metering pump**

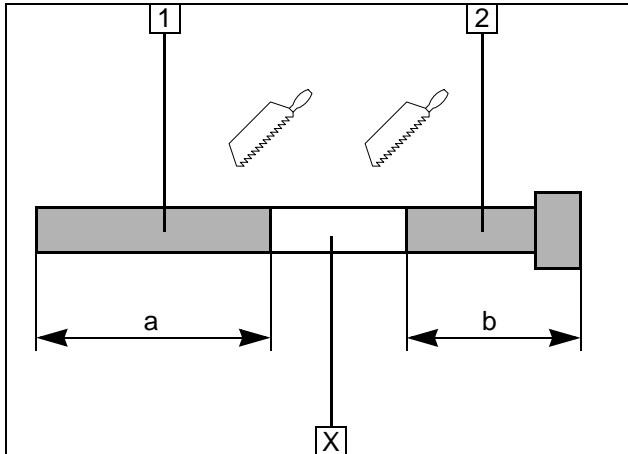
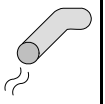

**Exhaust system**

- 1 Exhaust pipe  
a = 200 mm
- 2 Exhaust end section  
b = 350 mm

Discard section X

**Preparing exhaust pipe**

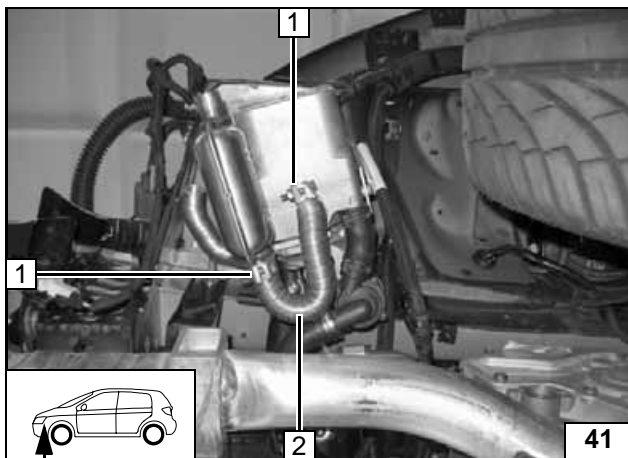

- 1 Hose clamp [2x]
- 2 Exhaust pipe

**Installing muffler**

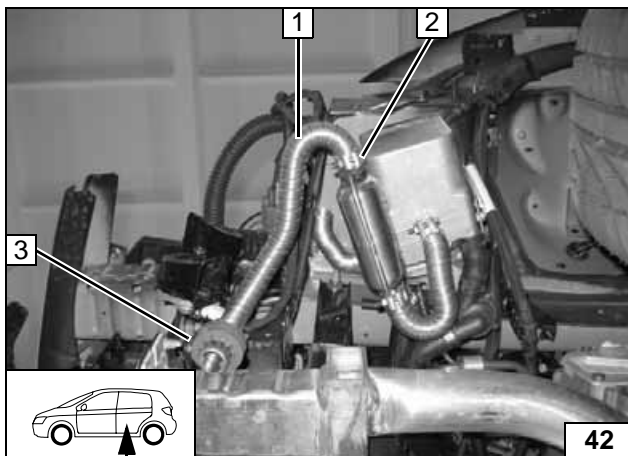

- 1 Exhaust end section
- 2 Hose clamp
- 3 Red (rt) rubber isolator with groove

**Installing exhaust end section**

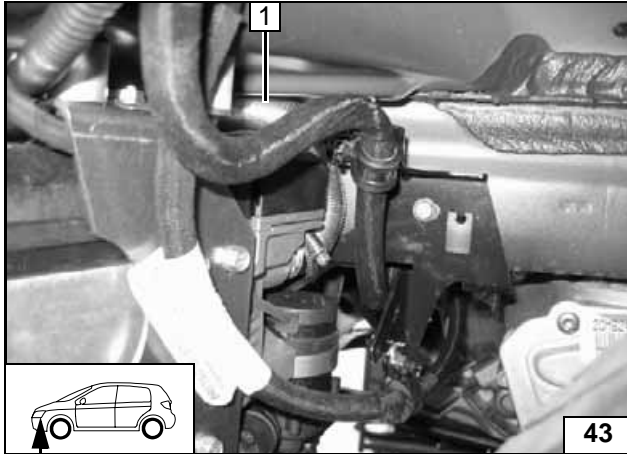

**Combustion air**

- 1 Combustion-air intake pipe



**Installing intake pipe**

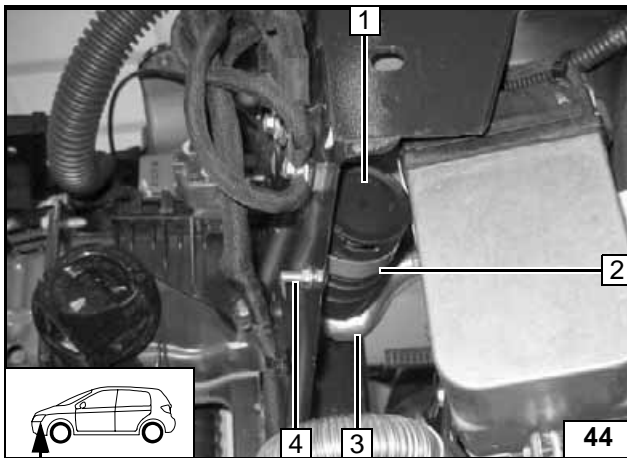

- 1 Combustion-air intake muffler
- 2 48 mm dia. p-clamp; rubber coating removed
- 3 Combustion-air intake pipe
- 4 M6x20 bolt, original vehicle hole, M6 flanged nut

**Installing muffler**

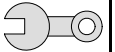

## Final Work

### WARNING!

Reassemble the disassembled components in reverse order.

Check all hoses, clamps and all electrical connections for firm seating.

Secure all loose cables using cable ties.

Only use manufacturer-approved coolant.

Spray the heater unit components with anti-corrosion wax (Tectyl 100K, Order No. 111329).

- Connect the battery
- Fill and bleed the coolant circuit according to the vehicle manufacturer's specifications.
- Set the digital timer.
- Set the manual air conditioning or automatic air conditioning according to the "operating instructions for the end customer".
- Check the proper operation of the additional heater, see the operating instructions/installation instructions.
- Attach the "Switch off additional heater before refueling" sticker to the left-hand B-pillar.

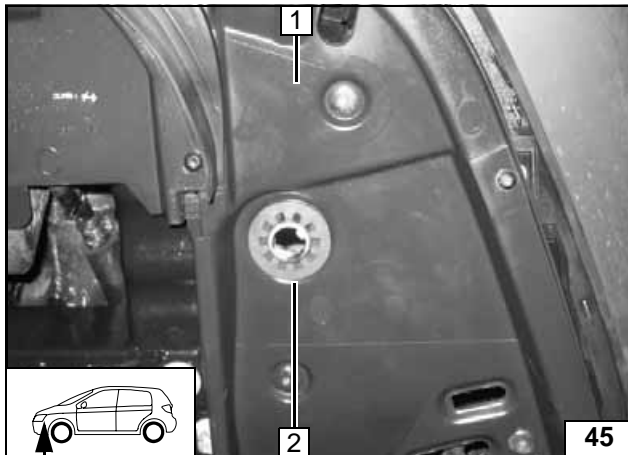

Drill 42 mm dia. hole in wheel-well inner panel **1** at position **2**, align exhaust end section flush on red (rt) rubber isolator as shown and mount.



**Mounting  
rubber  
isolator**

**Webasto**  
Feel the drive



**Operating Instructions for End Customer**

Please remove page and add to the vehicle operating instructions.



**Note:**

We recommend matching the heating time to the driving time.

Heating time = driving time

**Example:**

For a driving time of approx. 20 min. (in one direction), we recommend not exceeding a switch-on time of 20 min.

If the summer/winter switch option has been installed, this must be switched in accordance with the time of year. The heater unit will then only switch on the vehicle fan to ventilate the vehicle interior in the position Winter  heat and in the position Summer .

Before parking the vehicle, make the following settings:

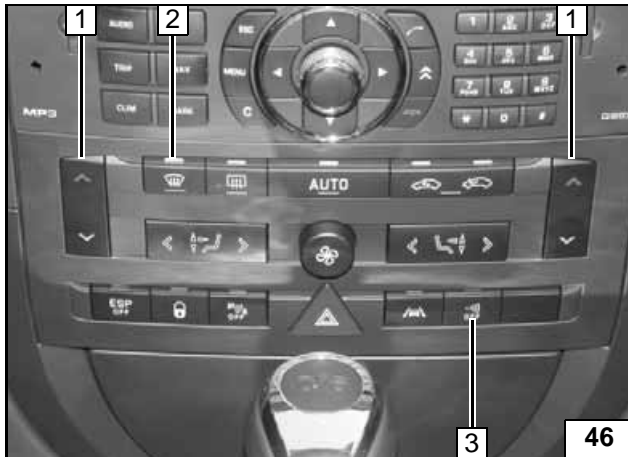

Following adjustment, be sure to wait approx. 30 seconds until switching off engine!

- 1 Temperature to "max." [2x]
- 2 Air outlet to windshield
- 3 Deactivate passenger compartment monitoring



After ignition switch is actuated, A/C control panel starts in automatic mode



**Adjusting automatic air-conditioning**



**Automatic air-conditioning**

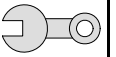

### Template for Fuel Standpipe

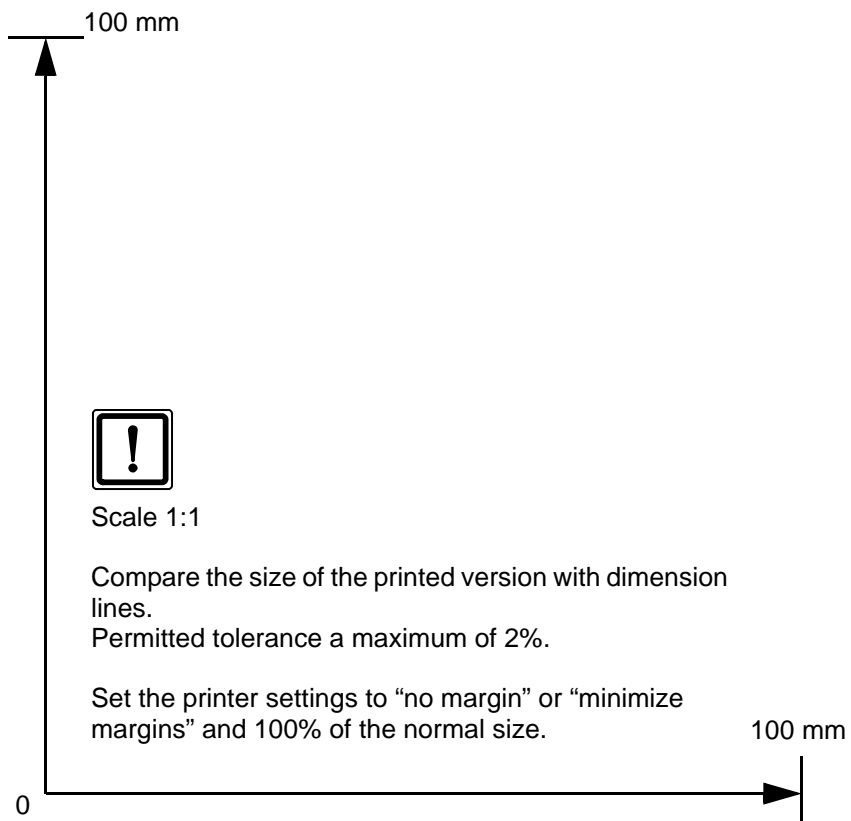
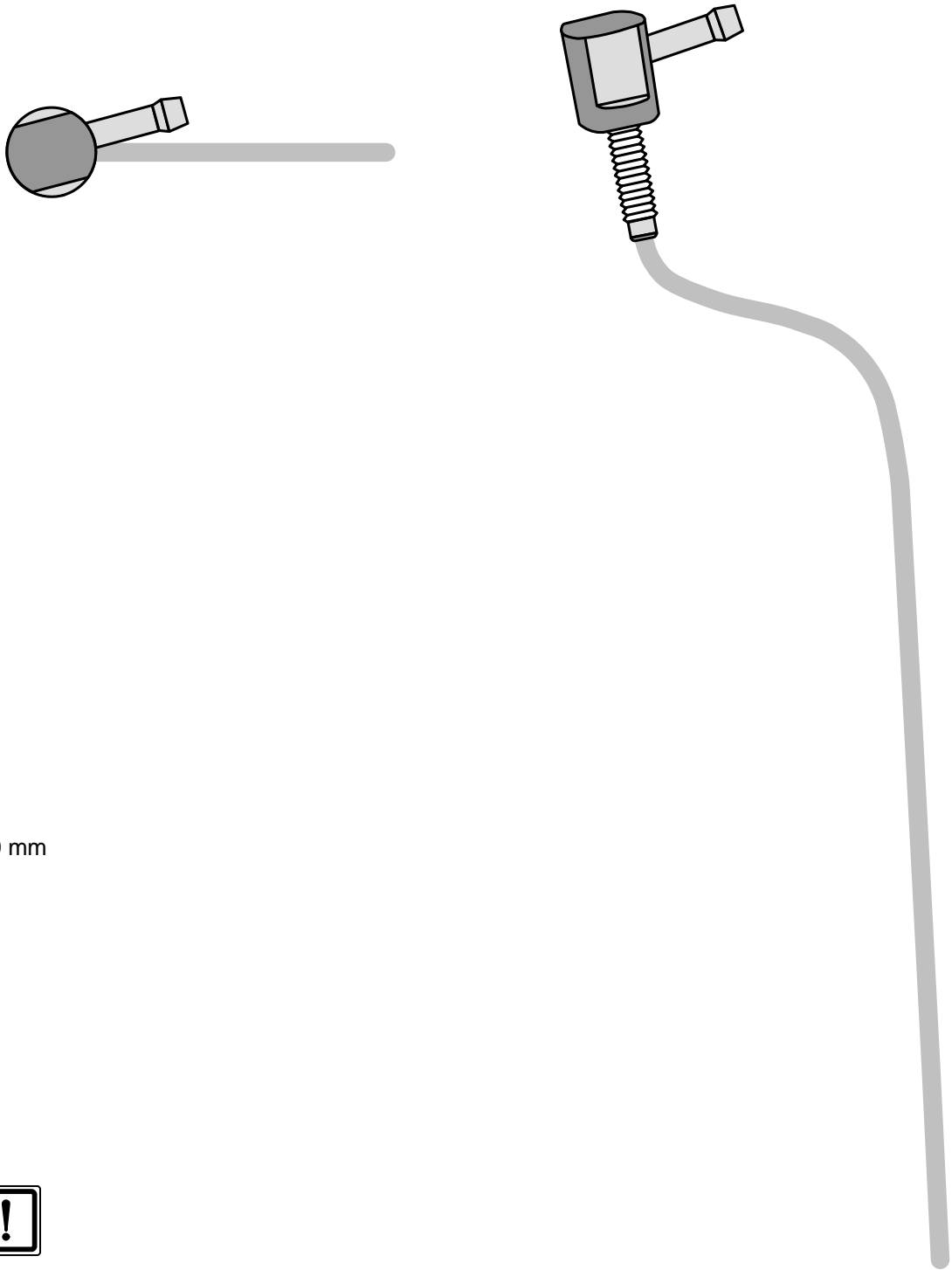

Scale 1:1

Compare the size of the printed version with dimension lines.  
Permitted tolerance a maximum of 2%.

Set the printer settings to "no margin" or "minimize margins" and 100% of the normal size.