

Water heater unit

Thermo Top Z/C Auxiliary Heating Test mark ~~~ S 289

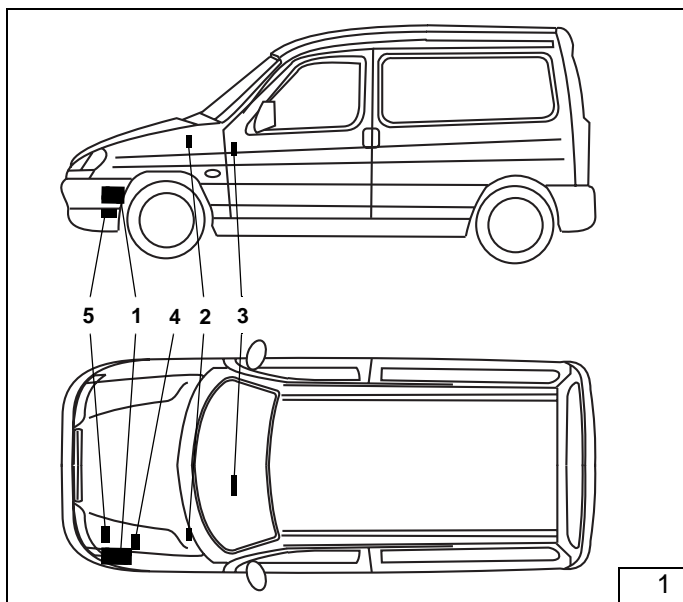

**Pre-heater Z equipment
for auxiliary heater C**

CITROËN Berlingo

2.0l Diesel

Peugeot Partner

2.0l Diesel

Factory installed auxiliary heating

Not for automatic transmission!

Legend for figure 1:

- 1 Thermo Top Z Heater Unit
- 2 Blade-Type Fuse Holder and Blower Relay
- 3 Time switch
- 4 Circulation pump
- 5 Silencer

Special tools

- Vice-grip wrench
- Torque spanner for 2.0 - 10 Nm

Table of Contents

CITROËN Berlingo	1	Final work	12
Peugeot Partner	1		
Heater unit / Accessory kit	2		
Validity	2		
Foreword	2		
General Instructions	3		
Preliminary Work	3		
Heater Unit Installation Location	3		
Blade-Type Fuse Holder, Blower Relay and supplementary relay	4		
Blower control	4		
Time switch	6		
Heater Unit Control	6		
Connection to the water circuit	7		
Exhaust System	8		
Adjusting the Underride Protection	10		

Heater / Accessory kit

Quantity Name

Order No.

1 Accessory kit Thermo Top Z for Thermo Top Z/C

13 001 82B

Validity

Manufacturer	Model	EG-BE no.
Citroen	Berlingo	e2*98/14*0201*..

Engine type	Engine model	Power in kW	Engine capacity in cm ³
RHY	Diesel / 4	66	1997

Manufacturer	Model	EG-BE no.
Peugeot	Partner	e2*98/14*0202*..

Engine type	Engine model	Power in kW	Engine capacity in cm ³
RHY	Diesel / 4	66	1997

Foreword

These non-binding upgrade instructions apply to the Citroen Berlingo Diesel 2,0l and Peugeot Partner 2.0l Diesel - for validity, see page 2000 - from model year and later, assuming technical modifications to the vehicle do not affect installation, any liability claims excluded. Depending on the vehicle version and equipment, modifications may be necessary during installation with respect to these installation instructions. However, where this is the case the stipulations in the "installation instructions" and "operating instructions" for the **Thermo Top Z/C** should be observed. The corresponding rules of technology should be observed during the installation work.

General instructions

- Cover unfinished body areas, such as drill holes, with corrosion protection.
- Secure hoses, wires, and cable harnesses with cable clips and cover with protective hoses at friction locations.
- Fit sharp edges with edge protection (split open plastic hose).
- All lengths in millimeters unless otherwise indicated.

Preliminary work

Engine Compartment

WARNING:

Disconnect the battery.

Let off pressure from the cooling system.

Vehicle Exterior

- Remove the left front wheel.
- Remove the left wheel-house panel
- Remove the windshield wiper arms.
- Remove the front left engine side panel
- Remove the underride protection

Heater unit installation location

NOTE:

The bumper is only disassembled for documentation purposes.

- The heater unit (2/1) is installed in the left of the engine compartment as seen in direction of travel, between the wheel house and the bumper.

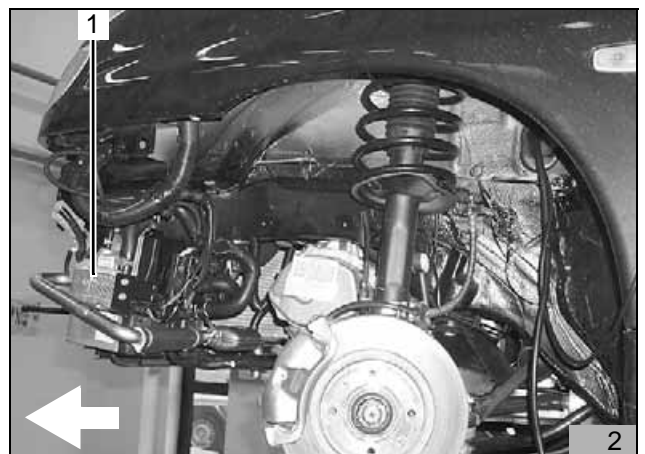

Blade-Type Fuse Holder, Blower Relay and Supplementary Relay

WARNING:

When drilling, watch out for underlying wires.

NOTE:

Use edge protectors for all cable feed-throughs.

- Transfer the hole template for the blower relay K3 (3/2), the retaining plate for the blade-type fuse holder (3/4), the supplemental relay (3/3) and the grounding point (3/1) to the engine compartment rear bulk according to image 3.
- Drill \varnothing 2.5mm hole for blade-type fuse holder (3/4) retaining plate.
- Drill \varnothing 4mm holes for the blower relay K3, supplementary relay, and grounding point.
- Fasten the retaining plate for the blade-type fuse holder with 3.5x13 self-tapping screw.
- Fasten the blower relay, supplementary relay and grounding point with 5.5x13 self-tapping screw.
- Insert the blade-type fuse holder on the retaining plate.
- Run the cable harnesses for the time switch and blower control along the original vehicle cable harness into the cooling water reservoir and from there through the existing ducts into the interior.
- Run the cable harness for the heater unit (green, gn, and black, sw) and the cable harness for the circulation pump (blue, bl, und black, sw) along the original vehicle cable harness to the heater unit.

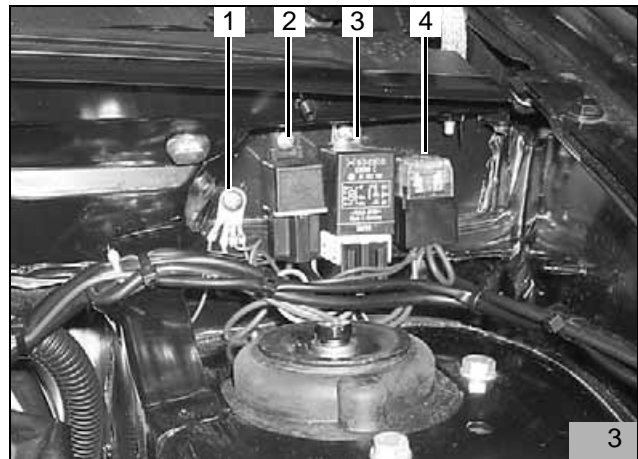

Blower control

Vehicle without air conditioning

NOTE:

Depending on the vehicle equipment, the wire to be cut can be black or red.

- Cut the black or red (4/2,4) wire about 50 mm before the blower motor (4/3).
- Crimp on the flat blade connections
- Connect according to illustration 5 in the circuit diagram.
- Connect the black (4/5) wire from the blower relay K3 with the black or red (4/4) wire to the blower motor.
- Connect the red (4/1) wire from the blower relay K3 with the black or red (4/2) wire to the vehicle fuse.

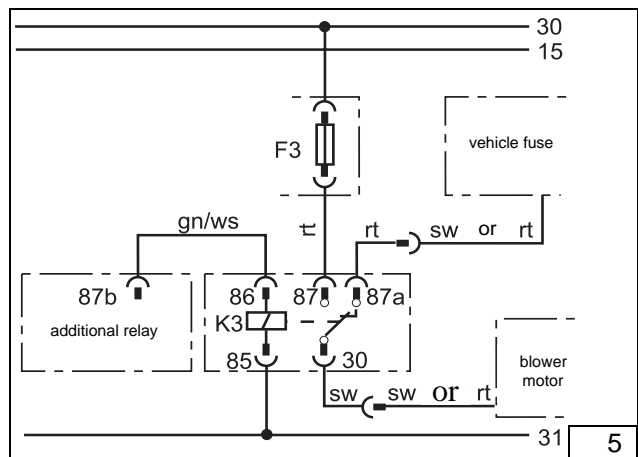
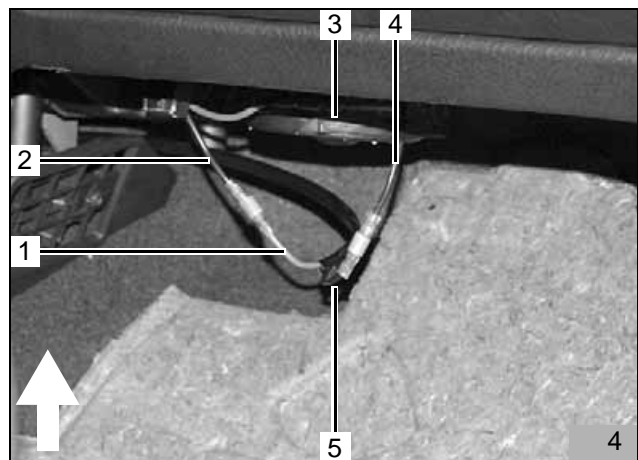

Vehicle with air conditioning

- Pull the 4-pin connector (6/2) from the blower motor.

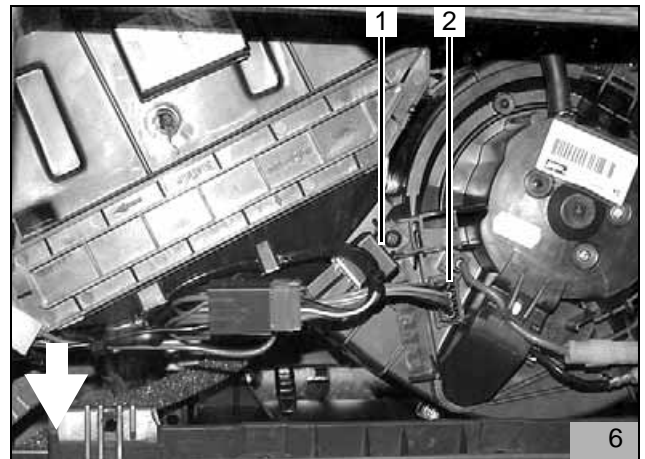

- Connect the blower adapter and blower relay K3 according to figure 8 in the circuit diagram.
- Crimp the blade receptacles onto the red and black wire (7/2) from the blower relay K3, complete the connector housing and connect with the same colors in the connector housing (7/1) for the adapter.
- Connect the connector (7/7) with the clutch (7/3) and insert the connector (7/6, 6/2) in the blower motor.
- Fasten the relay (6/1, 7/5) with the available bolt according to figure 6.
- Secure wires with cable ties.

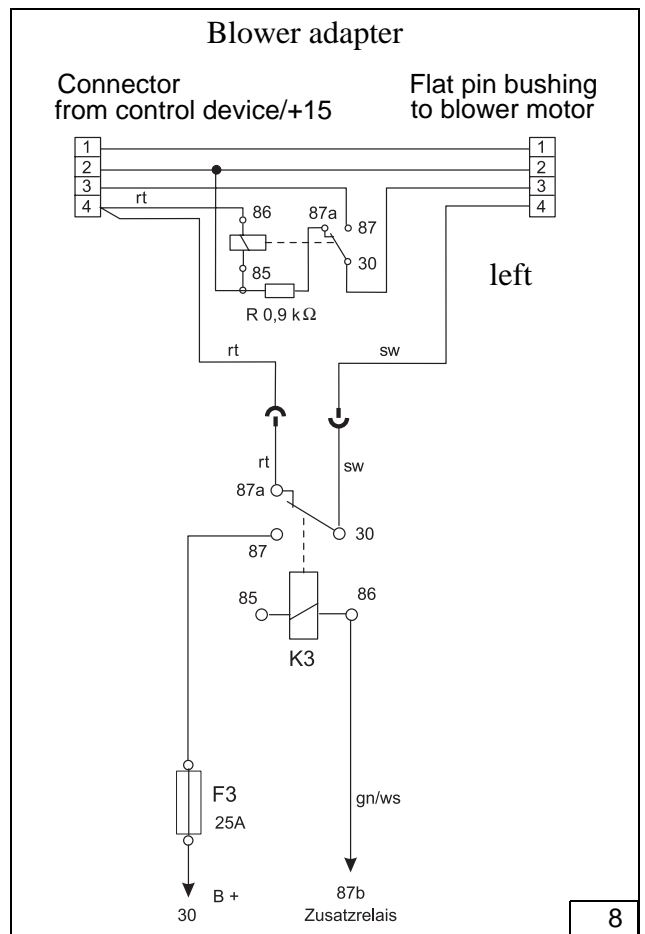
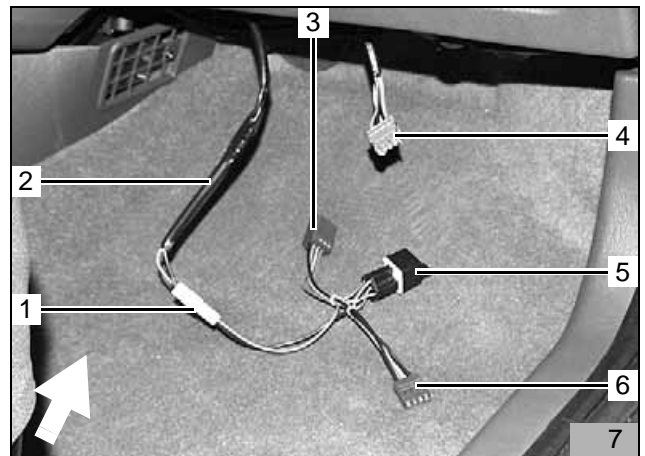

Time switch

WARNING:

When installing the time switch, do not press on the LCD display.

NOTE:

The installation position shown for the timer switch (9/1) is a recommendation! Before installing, please confirm the installation location with your customer.

- Attach the drilling template for the time switch (9/1) at the position suggested in figure 9.
- Drill two holes as on the template.
- Remove the template.
- Assemble the fastening lug with self-tapping screw

NOTE:

Note the direction of the catch teeth (see Installation Instructions)! Check for wear protection when placing the cable harness.

- Pull the time switch cable harness through the hole and connect the plug to the time switch.
- Slide on the time switch



Controlling the Heater Unit

The heater is controlled at the compact connector X14 (10/5) on the heater unit.

- Run the heater unit control cable harness according to figure 10 to the separation point and cut.
- Separate the black wire (10/3.4) (original vehicle power on signal) about 30 mm before the 6 pin compact connector X14 (10/5) Pin 3.
- Connect to the enclosed butt connectors according to the circuit diagram for the enclosed general installation instructions (crimp and sleeve)
- Connect the green wire (10/1) from the blower relay K3/86 with the black wire (10/4) to the heater unit.
- Connect the black (10/2) wire from the supplementary relay E2 with the black wire (10/3) from the original vehicle cable harness (original vehicle power on signal).

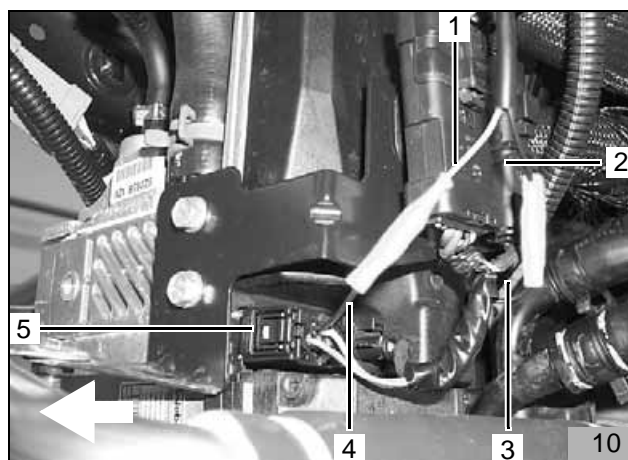

Connection to the water circuit.

NOTE:

Tighten all hose clamps to 2.0 + 0.5 Nm. Any fuel running off should be collected using an appropriate container!

Install hoses so that they are kink-free!

Observe the flow direction of the circulation pump from the engine to the heater unit.

The following sections describe the installation of the heater unit "inline" in the cooling water circulation of the vehicle (figure 11).

Legend for Figure 11:

- 1 Expansion reservoir
- 2 Coolant thermostat
- 3 Vehicle engine
- 4 Circulation pump
- 5 Heater unit
- 6 Heat exchanger (vehicle)
- 7 Cooler

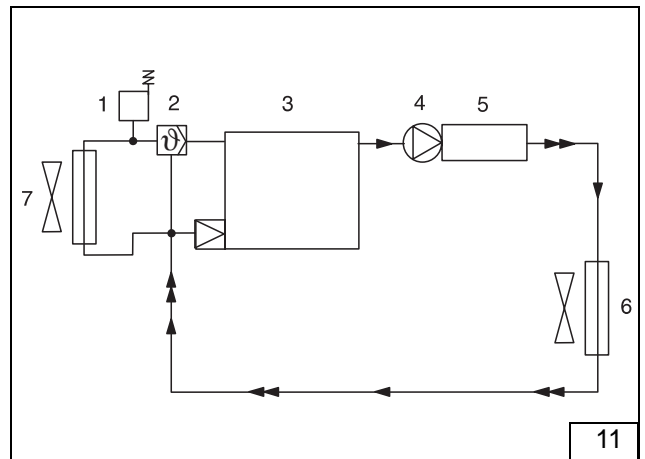

- Remove the vehicle's own water hose (12/1.3) from the engine outlet to the heater unit water inlet after the 90° bend at position at position (12/5) according to figure 12.
- Dispose of the original vehicle hose section (12/1).

NOTE:

The hose clamps (12/2) will be used again.

- Shorten the protective hose from the original vehicle water hose (12/3) by approx. 30 mm up to position (12/4).
-

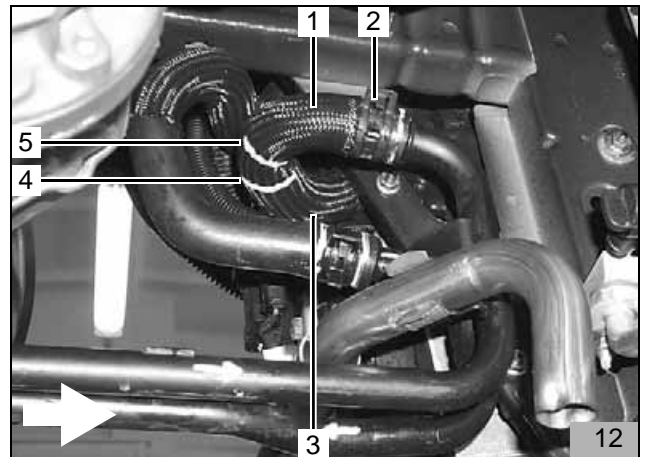

NOTE:

Observe the flow direction (arrow) of the circulation pump!
(Pressure side facing left to the heater unit)

- Fasten the bracket (13/3) (with oblong hole) with flanged nuts to the existing stay bolts (13/2) according to figure 13.
- Fasten the circulation pump (13/5) on the bracket (13/3) with the rubberised tube clamp (13/1), M6x20 bolt, and flanged nut.
- Fit the water hose (13/4, 12/3) to the heater unit water inlet on the circulation pump water outlet and secure it with a hose clamp

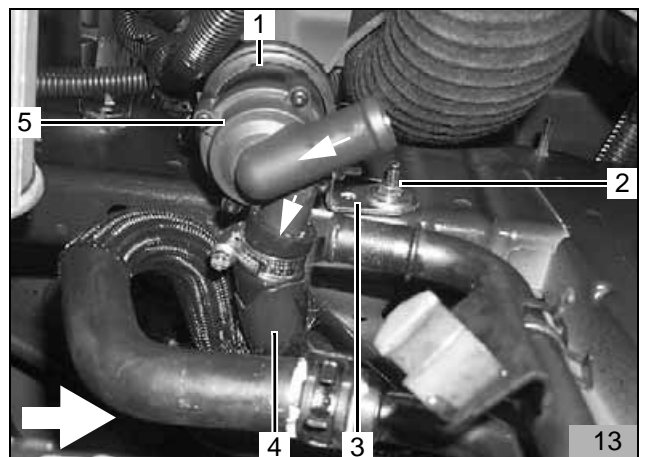

- Fit the enclosed 180° bend (ø 20mm) (14/1) with the long side on the circulation pump water inlet, align according to figure 14 and secure it with a hose clamp.
- Fit the enclosed 180° bend (ø 18mm) (14/3) on the tube line (14/2) from the engine outlet, align according to figure 14 and fasten with the original hose clamp.
- Connect both 180° bends with connecting pipe 18/20 and hose clamps according to figure 14.
- Run the circulation pump cable harness (14/4) to the circulation pump and cut.
- Make connections according to the circuit diagram in the enclosed general installation instructions.
- Crimp on the plug-in contacts.
- Complete the connector housing so that the following connections are made when this is put together:
Blue wire from the supplementary relay 87b with the black wire to the circulation pump.
Brown ground wire with brown wire to the circulation pump.
- Connecting the connector

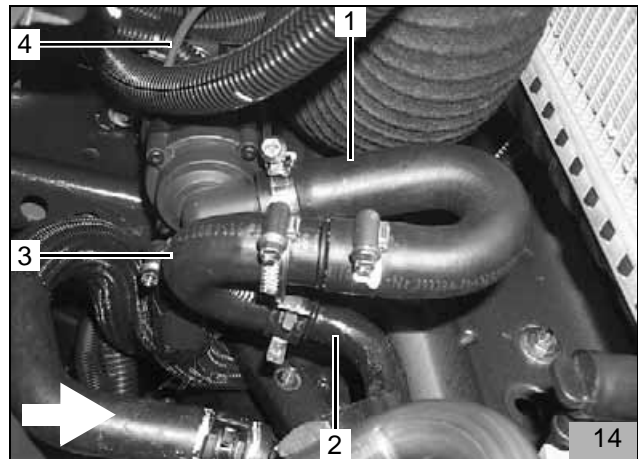

Exhaust System

WARNING:

When installing the exhaust system, ensure sufficient space to other components.

- Remove the exhaust pipe end piece (15/1).

- Drill open the tube bracket rivet (16/1) with a Ø 7.0mm drill.
- Dispose of tube bracket.

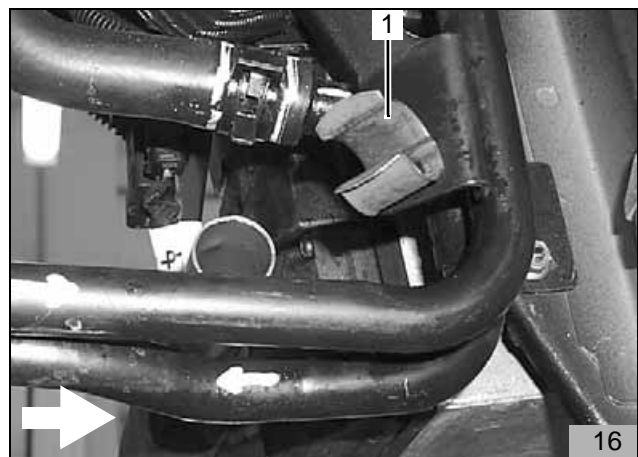
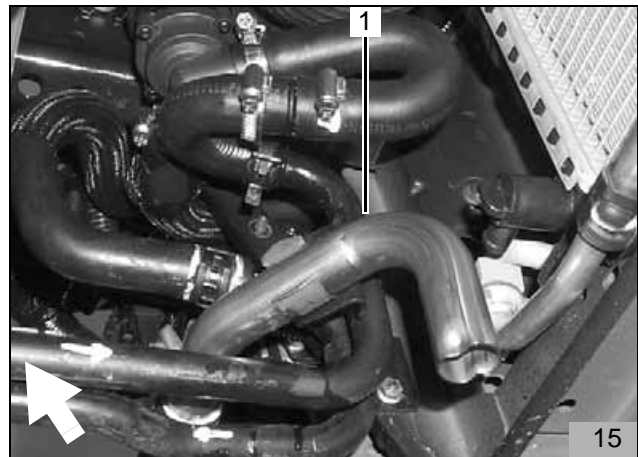

- On the end of the exhaust pipe (17/4), saw 2 slots of 20x1 mm (17, 2,3).

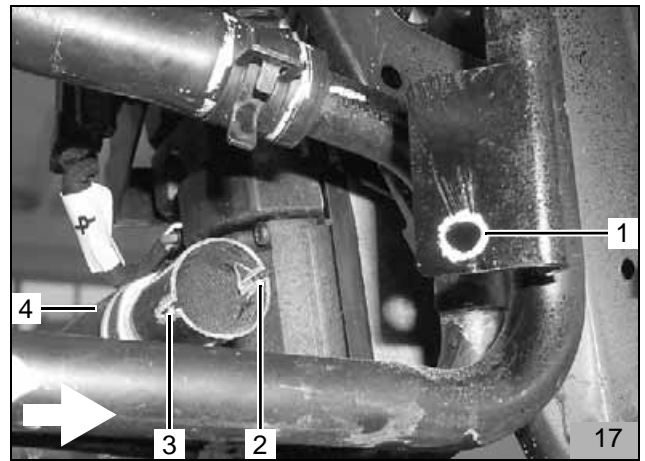

- Loosely attach the exhaust silencer (18/1) with the hose clamp (18/5) on the exhaust line (18/6, 17/4).
- Fasten the bracket (18/3) with the short leg on the hole (17/1) with the M6x20 bolt (18/4) and flanged nut.
- Align the silencer according to figure 18 and fasten with bolt M6x20 (18/2) and flanged nut.
- Tighten the hose clamp (18/5).

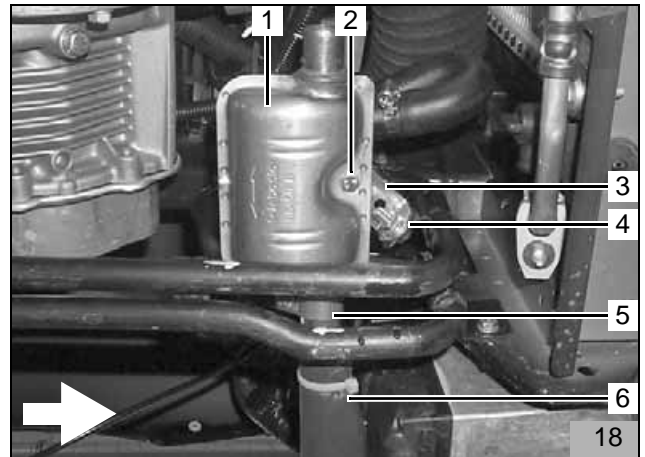

- Shorten the exhaust pipe end piece as shown in figure 19.
- Dispose of the hose section (19/1).
- On the sawed off end (19/2) of the exhaust pipe (19/3), saw 2 slots of 20x1 mm.

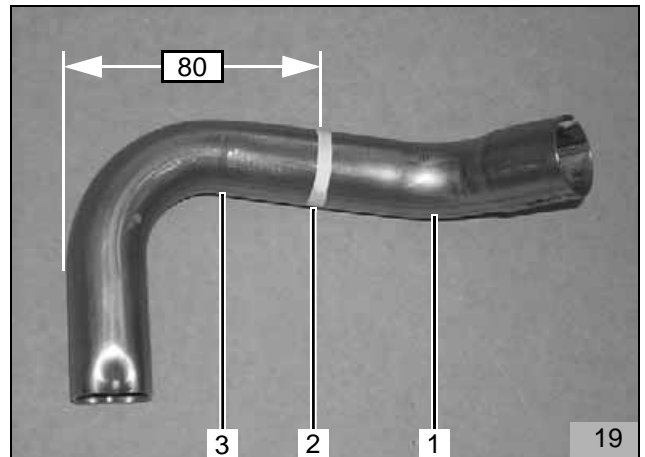

- Attach the exhaust pipe end piece (20/1, 19/3) to the exhaust silencer, align vertically facing down and secure with hose clamps.

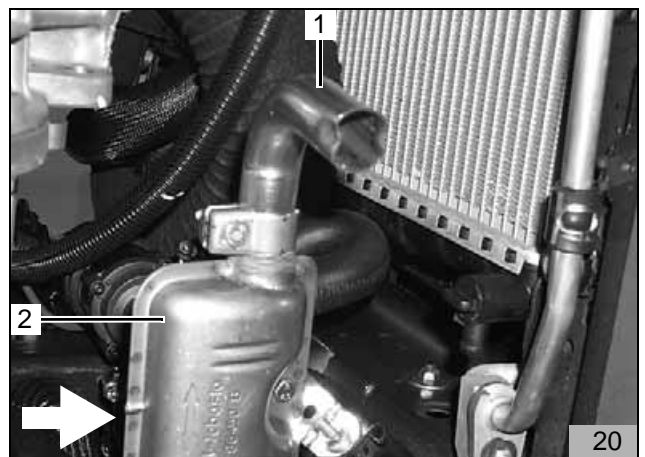

Preparing the underride protection

- Cut out the underride protection in the exhaust opening area (21/1) as shown in figure 21.

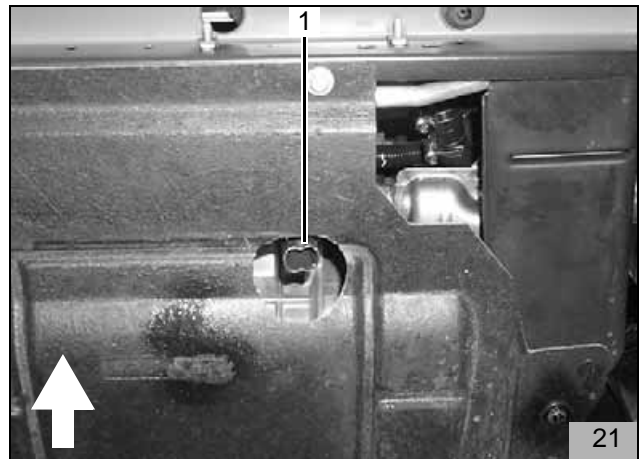

Space for notes

Final work

- Connect the vehicle battery
- Reassemble disassembled components in reverse order.
- Check that all hose lines, hose and tube clamps, and all electrical connections are securely fastened.
- Secure all loose cables using cable clips.
- Spray heating unit components with anti-corrosion wax (Tectyl ML, Order No. 111329).
- Start the engine, bleed the water circuit according to the vehicle manufacturer's specifications, top up with cold water.
- Set vehicle temperature to "warm".
- Switch on the Webasto heating, see "Operating and Installation Instructions"