

Water Heater Unit



Thermo Top E Additional Heater

00 0003

Thermo Top C Additional Heater

00 0002

Thermo Top P Additional Heater

00 0104

Installation Instructions

Audi A3

1.6 MPI and 2.0 FSI
from Model Year 2006
Left-hand drive vehicle



WARNING!

Hazard warning:

Incorrect installation or repair of Webasto heating systems may cause a fire or result in the emission of carbon monoxide, which can be fatal. Serious or fatal injuries can be caused as a result.

Specialist company training, technical documentation, specialized tools and equipment are required to install and repair Webasto heating and cooling systems.

NEVER attempt to install or repair Webasto heating or cooling systems if you have not successfully completed the company training and thereby acquired the required technical skills, or if you do not have access to the required technical documentation, tools and equipment needed to carry out correct installation and repairs.

ALWAYS follow all Webasto installation and repair instructions and observe all warnings.

Webasto does not accept any liability for defects and damage that are attributable to installation by untrained staff.

Audi A3

Table of Contents

Validity	2	Climatronic fan controller	8
Heater Unit/Installation Kit	3	Premounting heater unit	11
Foreword	3	Preparing installation location	11
General Instructions	3	Installing heater unit	12
Special Tools	3	Fuel Connection	14
Explanatory Notes on Document	4	Coolant connection	17
Preliminary Work	5	Exhaust gas	21
Heater unit installation location	5	Final Work	22
Electrical system	6	Operating Instructions for End Customer	23
Fuse holder and relay K3	7		

Validity

Manufacturer	Model	Type	EG-BE No./ABE
Audi	A3	8P	e1 * 2001/116 * 0217 * ...

VW Golf V and Golf Plus

Engine type	Engine model	Output in kW	Displacement in cm ³
BSE	Gasoline	75	1598
BVY	Gasoline	110	1984

Vehicle and engine types, equipment variants and national specifications not listed in these installation instructions have not been tested. However, installation according to these installation instructions may be possible.

The installation location of a digital timer and summer/winter switch should be confirmed with the end customer before installation.

Audi A3

Heater Unit/Installation Kit

Quantity	Description	Order No.:
1	Retail accessories with desired heater control	See price list
1	Installation kit for Audi A3 1.6 MPI and 2.0 FSI	1312766A

Heater unit recommended for the respective vehicle class:

Vehicle	Heater unit
Compact car	Thermo Top E
Mid-size car, station wagon	Thermo Top C
Full-size car, van, offroader	Thermo Top P

The selection of the heater unit is based on the passenger compartment size of the vehicle and the level of comfort required by the customer!



Foreword

These installation instructions apply to Audi A3 1.6 MPI and 2.0 FSI vehicles - for validity, see page 2 - from model year 2006 and later, assuming technical modifications to the vehicle do not affect installation, any liability claims excluded. Depending on the vehicle version and equipment, modifications may be necessary during installation with respect to these installation instructions.

However, the stipulations in the "installation instructions" and "operating and maintenance instructions" for the *Thermo Top C/P/E* must always be observed.

The corresponding rules of technology and any information from the vehicle manufacturer should be observed during the installation work.

General Instructions

Installation should be carried out according to the general, standard rules of technology. Unless specified otherwise, fasten hoses, lines and wiring harnesses to original vehicle lines and wiring harnesses using cable ties.

Sharp edges should be fitted with edge protectors (split-open plastic hose).

Spray unfinished body areas, e.g. drilled holes, with anti-corrosion wax (Tectyl 100K, Order No. 111329).

Special Tools

- Torque wrench for 2.0 - 10 Nm
- Hose clamping pliers
- Unlocking tool

Explanatory Notes on Document

To provide you with a quick overview of the individual working steps, you will find an identification mark on the outside top right corner of the page in question.

Mechanical system

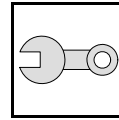

Electrical system

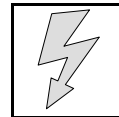

Water

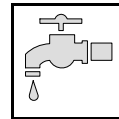

Fuel

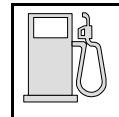

Exhaust gas

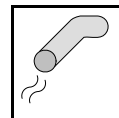

Combustion air

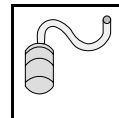

Special features are highlighted using the following symbols:



Specific risk of injury or fatal accidents.



Specific risk of damage to components.



Specific risk of fire or explosion.



Reference to general installation instructions of Webasto components or to the manufacturer's vehicle-specific documents.



Reference to a special technical feature.

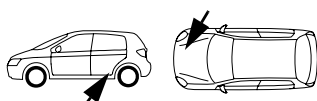

The arrow in the vehicle icon indicates the position on the vehicle and the viewing angle.

All dimensions are in mm!

Tightening torque of hose clamps = 2.0 + 0.5 Nm!

Tightening torque of Ejet screws, Ejet studs = 10 Nm!

Preliminary Work

WARNING!

- Open fuel tank cap, ventilate tank
- Close the tank cap again.
- Depressurize the cooling system.
- Copy the factory number from the original type label to the duplicate type label.
- Remove years that do not apply from the duplicate label.
- Attach the duplicate label (type label) in the appropriate place.
- Disconnect the battery "earth" or "ground" connection.
- Remove the battery.
- Remove the battery carrier.
- Remove the engine cover.
- Remove the front section of the right wheel well trim
- Remove the underride protection
- Remove the right-hand underbody trim
- Remove the rear bench seat
- Open the right-hand fuel sender service lid.
- Remove the footwell trim on the driver's side
- Remove the lower instrument panel trim on the driver's side
- Only with Climatronic: Remove the A/C control panel.

Remove page 23 "Operating Instructions for End Customer" and add to the vehicle operating instructions.

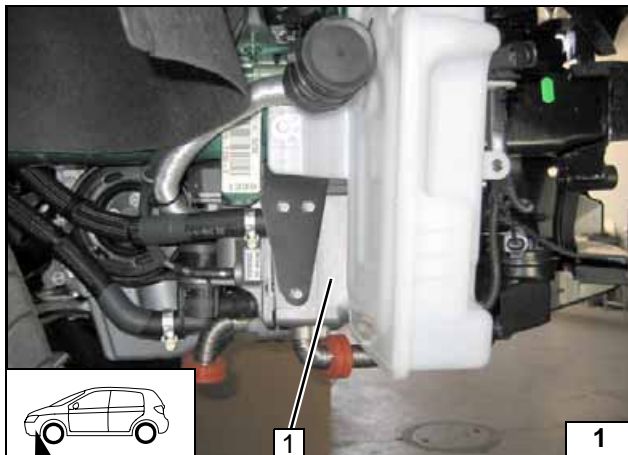

Heater unit installation location

1 Heater unit

Installation location



Electrical system

Wiring harness pass through

1 Original vehicle wiring harness pass through

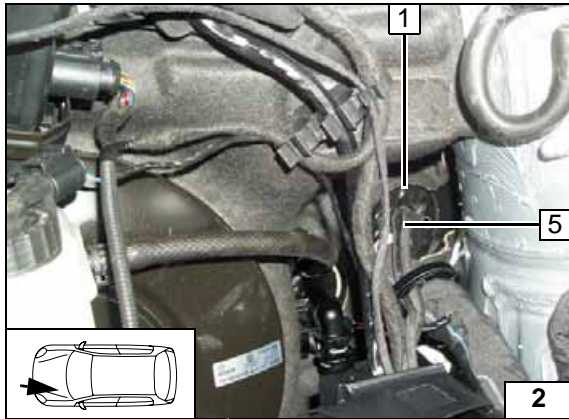

Digital timer and summer/winter switch option

1 Digital timer
2 12 mm dia. hole, summer/winter switch

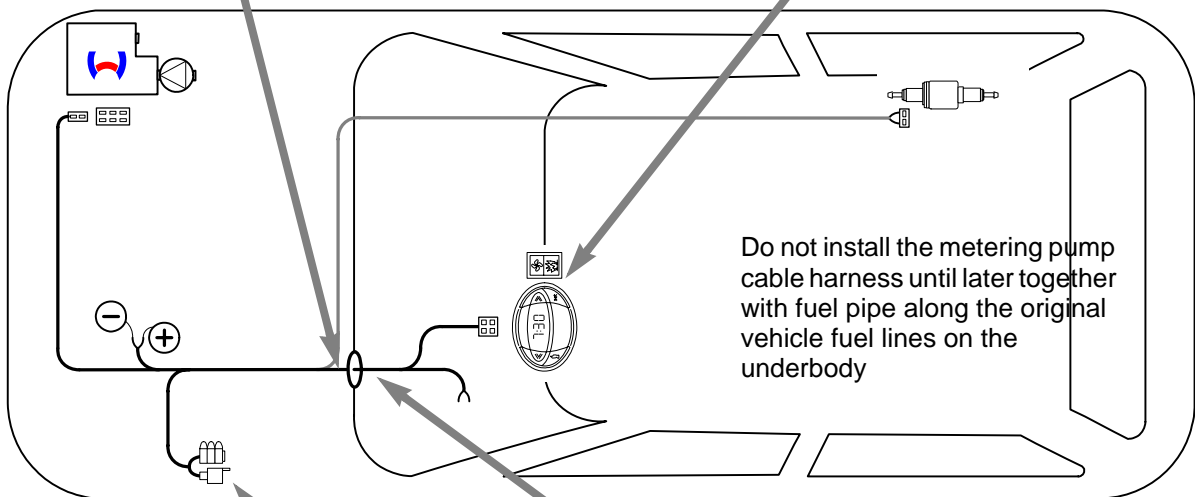

Wiring harness installation diagram

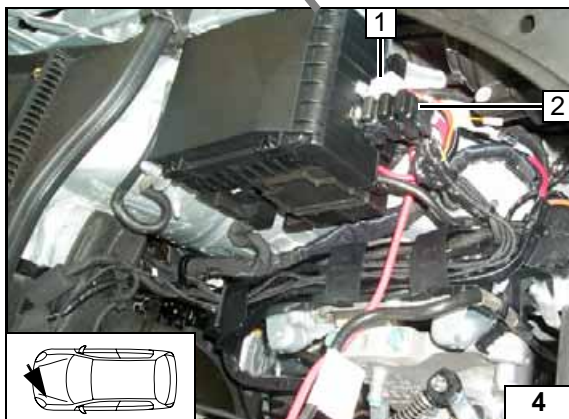

Fuse holder, relay K3

Description of installation for K3 relay 1 and fuse carrier 2 on Page 7

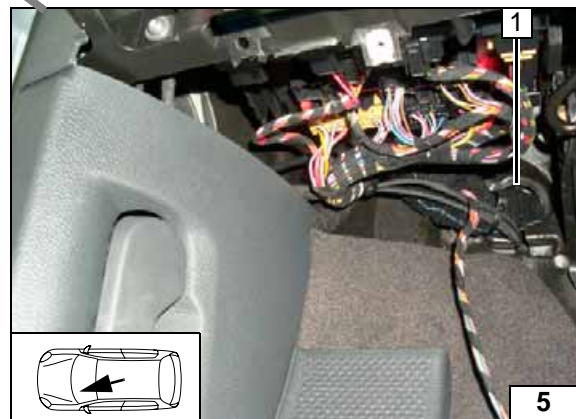

Wiring harness pass through

1 Original vehicle wiring harness pass through

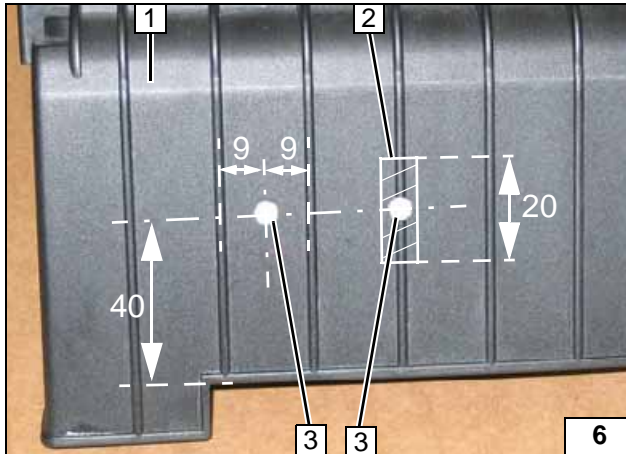
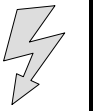

Fuse holder and relay K3

Countersink holes **3** from behind for M5 countersunk head screws.

- 1** Cover of fuse/relay carrier in engine compartment
- 2** Cut away bar in shaded area
- 3** 5.0 mm dia. hole [2x]



Holes for fuse holder and K3 relay

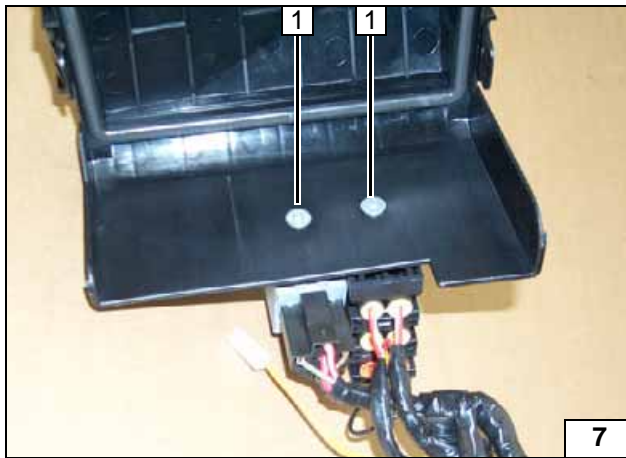

- 1** M5x12 countersunk head screw [2x]

Installing fuse holder and K3 relay

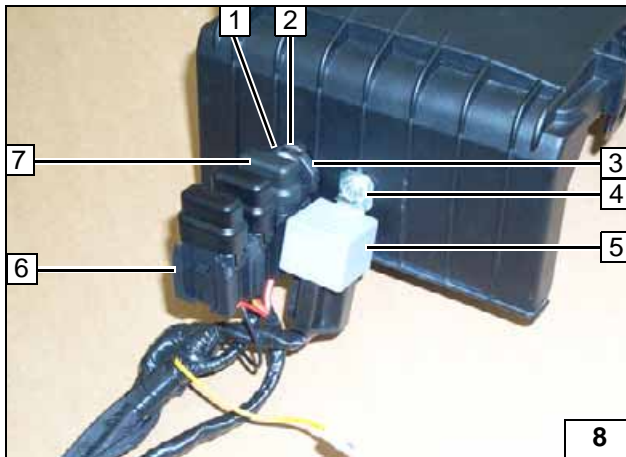

On vehicles with Climatronic, replace 25 A fuse F3 **7** with 5 A fuse provided.

- 1** M5 flanged nut
- 2** Large diameter washer (between cover and retaining plate)
- 3** Retaining plate
- 4** M5 flanged nut
- 5** Relay K3
- 6** Fuse holder



Installing fuse holder and K3 relay

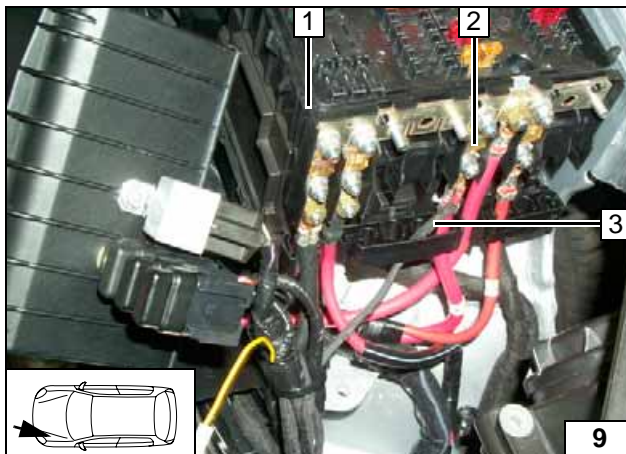

Route brown (br) ground wire to original vehicle ground support point below headlight and connect.

- 1** Fuse/relay carrier
- 2** Original main vehicle fuse
- 3** Red (rt) positive wire



Connecting positive and ground wire

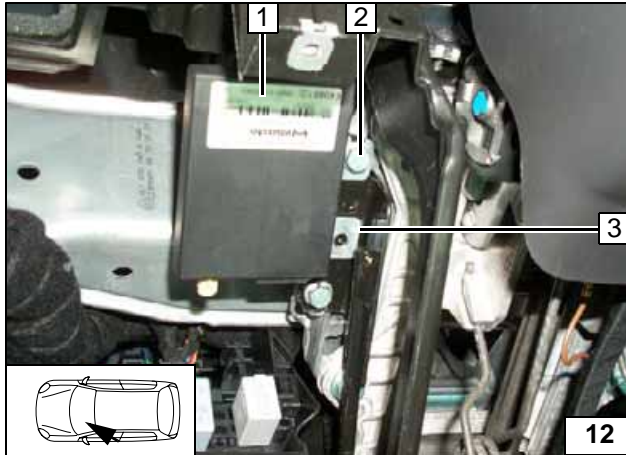
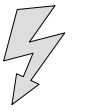

Remote option (Telestart)

If M6 screw 2 is not present, then use suitable M6 screw with spring lockwasher.
Drill out upper hole of bracket to 6.5 mm dia.

- 3 Bracket
- 1 Receiver
- 2 M6 bolt in existing threaded hole



Installing receiver

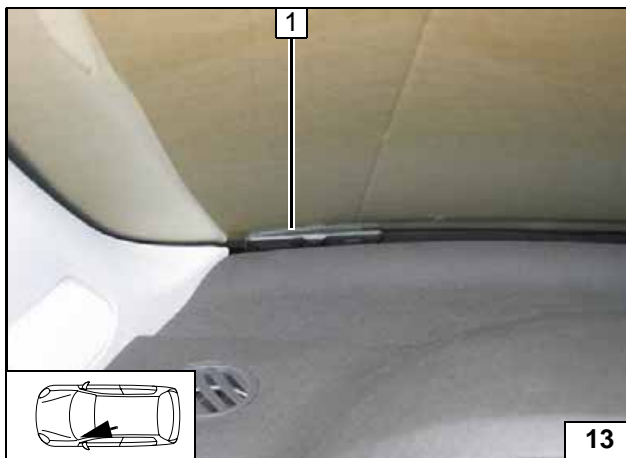

- 1 Antenna

Installing antenna

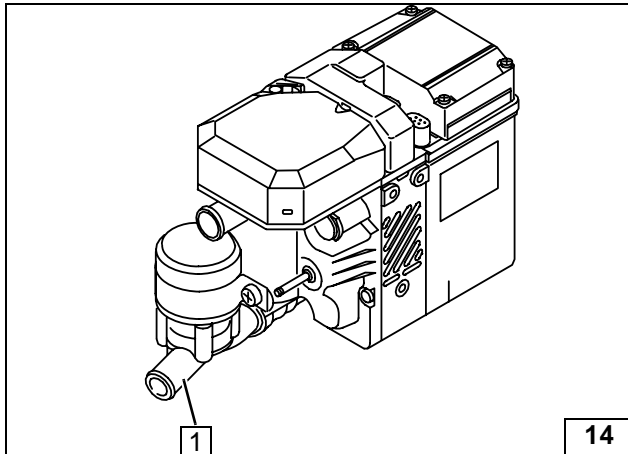
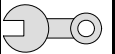

Premounting heater unit

- 1 193° circulating pump cover

Replacing circulating pump cover

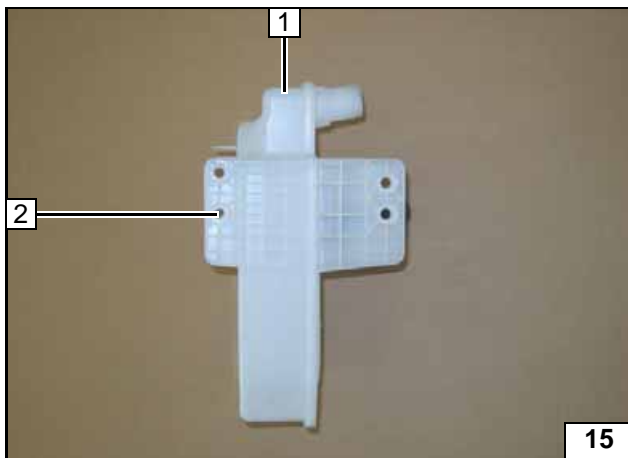

Preparing installation location

- 1 Washer reservoir
- 2 6.5 mm dia. hole



Preparing washer reservoir

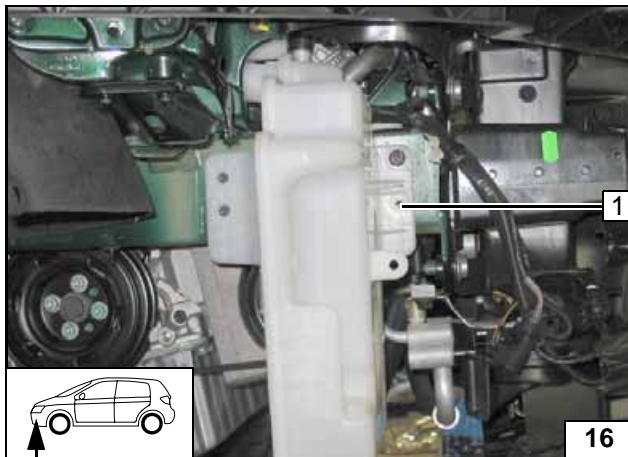

Install washer reservoir and copy hole pattern.

- 1 Hole pattern, 9.1 mm dia. hole



Copying hole pattern

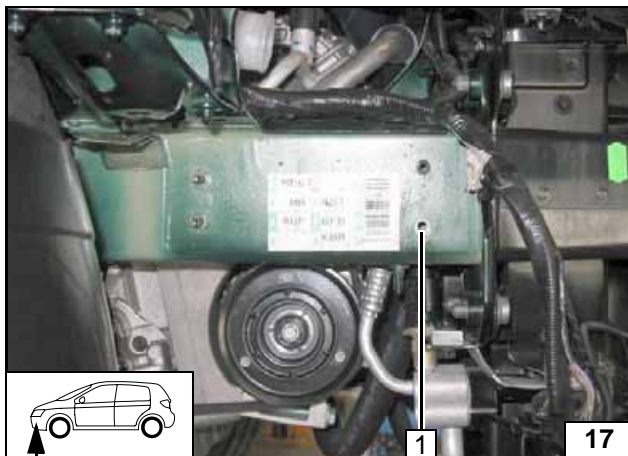

- 1 Rivet nut

Installing rivet nut

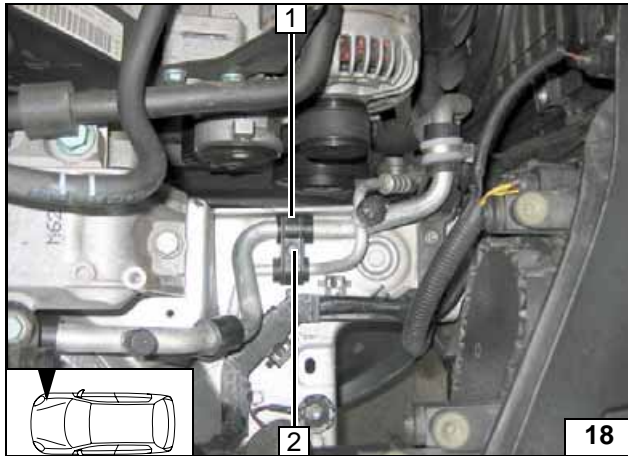
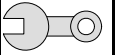

Remove plastic clamp **1** and drill out hole at position **2** to 6.5 mm dia.

2 Discard bolt



Removing plastic clamp



Remove plastic dowel at position **1** and drill out hole to 9.1 mm dia.

1 Rivet nut



Installing rivet nut

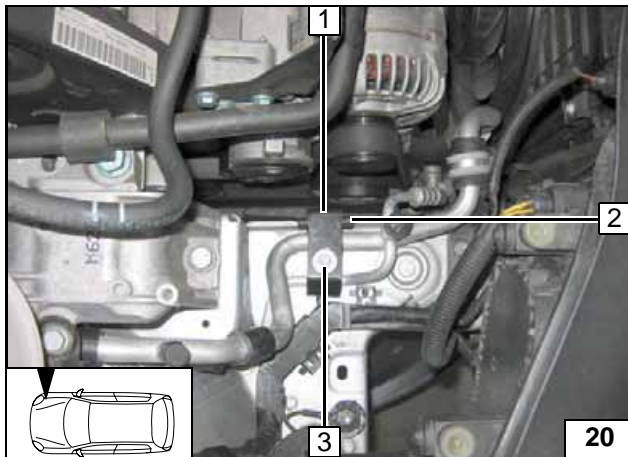

Reposition plastic clamp and loosely mount strut **1**.

- 2** Edge protection
- 3** M6x35 bolt, spring lockwasher, large diameter washer



Installing strut

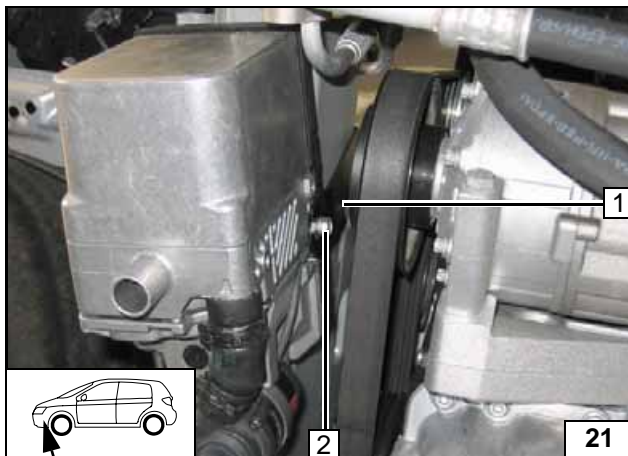

Installing heater unit

Connect wiring harness of heater unit before installing heater unit.

- 1** Strut
- 2** E-jot screw



Installing heater unit

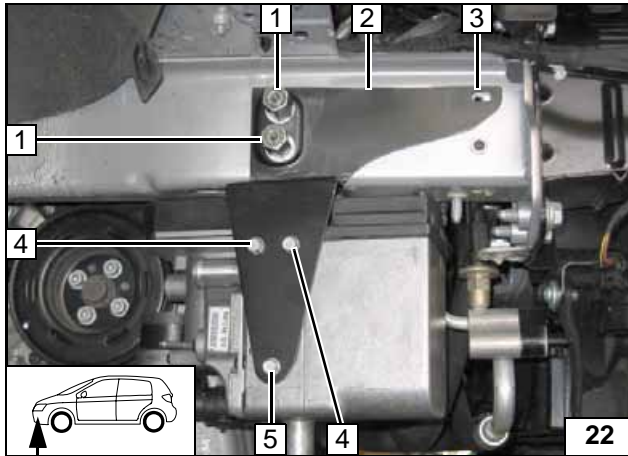
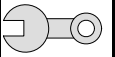

Position bracket during installation so that oblong hole and thread are aligned at pos. **3**. Insert two washers between bracket **2** and heater unit at pos. **5**.

- 1** M6x30 spacer nut, large diameter washer on existing stud bolt [2x each]
- 4** E-jot screw [2x]
- 5** E-jot screw



Installing bracket

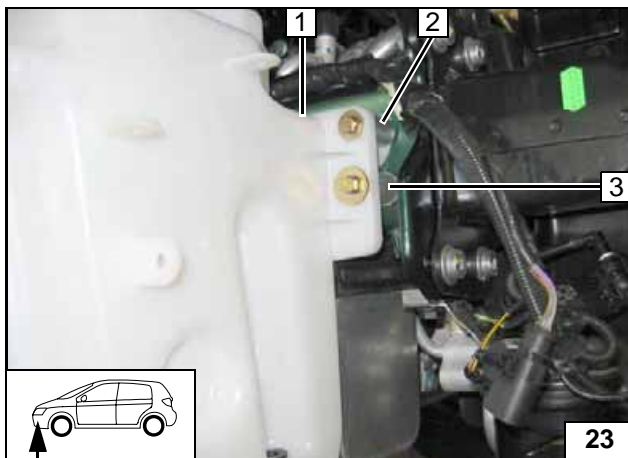

- 1** Washer reservoir
- 2** M6x60 bolt, spring lockwasher, large diameter washer, 30 mm spacer, existing thread
- 3** M6x60 bolt, spring lockwasher, large diameter washer, 30 mm spacer, large diameter washer, rivet nut

Installing washer reservoir

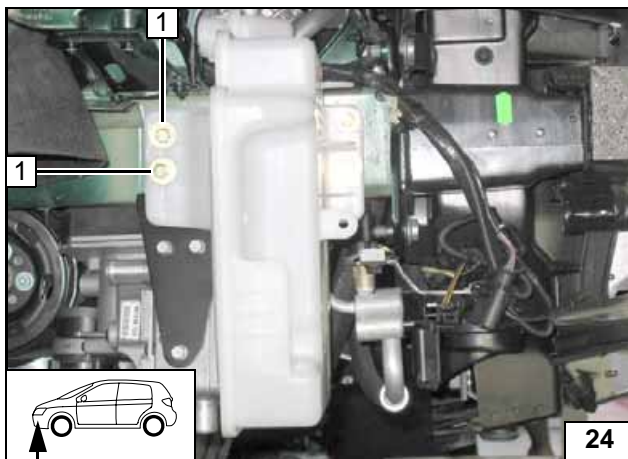

Tighten all screw connections.

- 1** M6x25 bolt, spring lockwasher, large diameter washer [2x each]



Installing washer reservoir



Fuel Connection

CAUTION!

Open the vehicle's fuel tank cap, ventilate the tank and then re-close the tank lock.

Catch any fuel running off with an appropriate container.

Install fuel line and metering-pump wiring harness so that they are protected against stone impact. Unless specified otherwise, always fasten using cable ties. Mount the fuel line and wiring harness with rub protection on sharp edges.

WARNING!

The fuel line and wiring harness are routed to the metering pump in as shown in the wiring harness routing diagram.

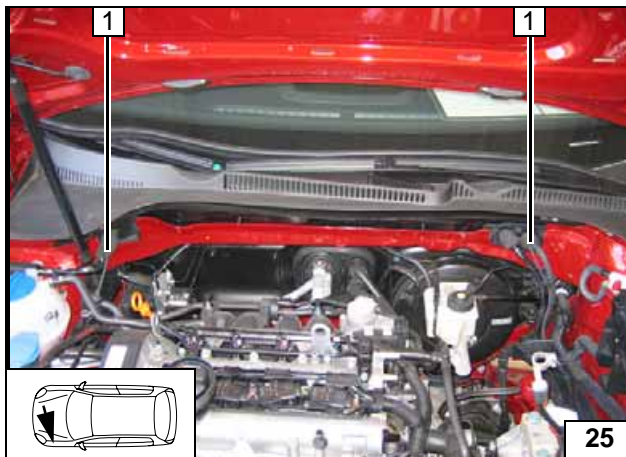

Ensure freedom of movement of wiper linkage.

- 1 Wiring harness of metering pump [2x]

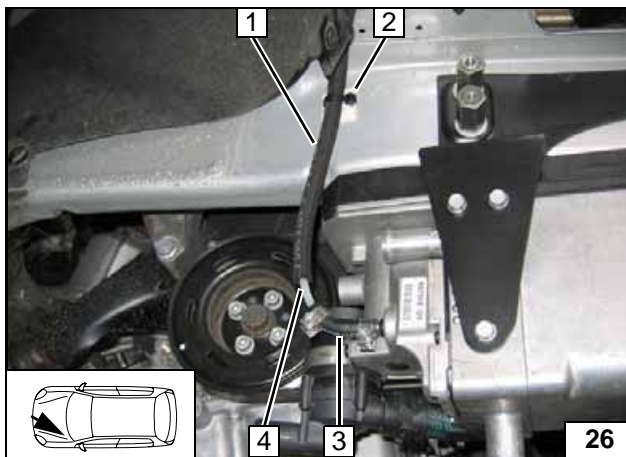

- 1 Cut fabric-reinforced hose to length of 1,100 mm
- 2 Mounting socket, cable tie
- 3 Hose section, 10 mm dia. clamp [2x]
- 4 Fuel line

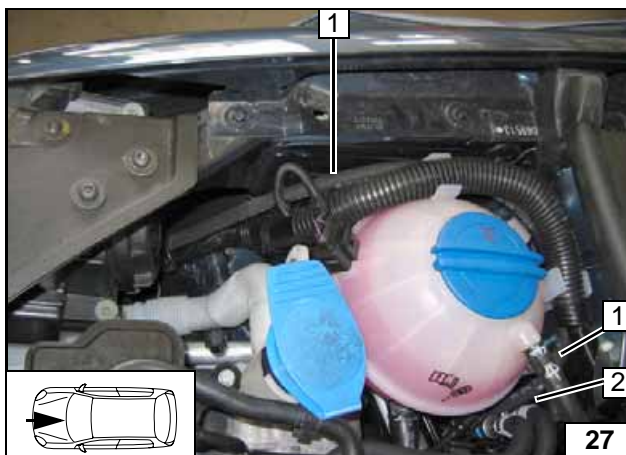

Route fuel line 1 to original vehicle line duct and route to underbody together with wiring harness of metering pump.



Installing wiring harness of metering pump

Connection on heater unit



Installing fuel line

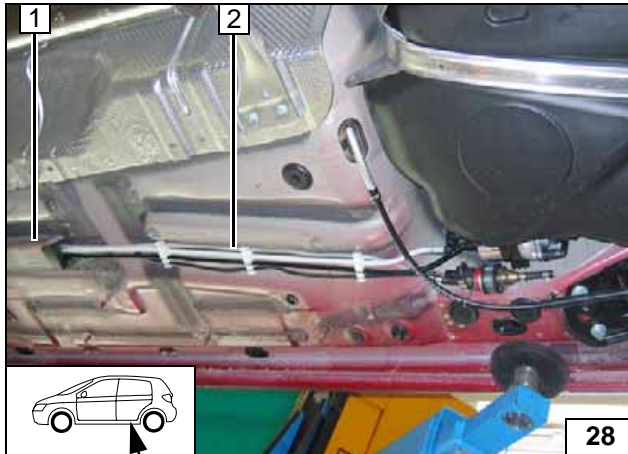
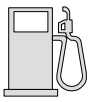

Route fuel line and wiring harness of metering pump along original vehicle fuel lines 2 to fuel tank.

- 1 Line duct



Routing fuel line and wiring harness of metering pump

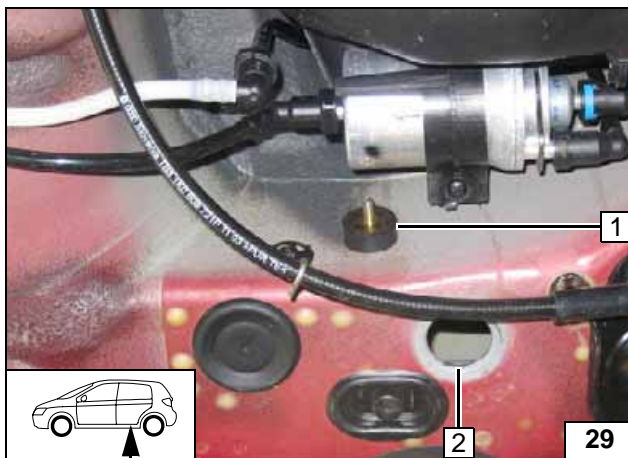

- 1 Silentblock, large diameter washer, M6 flanged nut
- 2 Remove sealing plug

Installing silent block

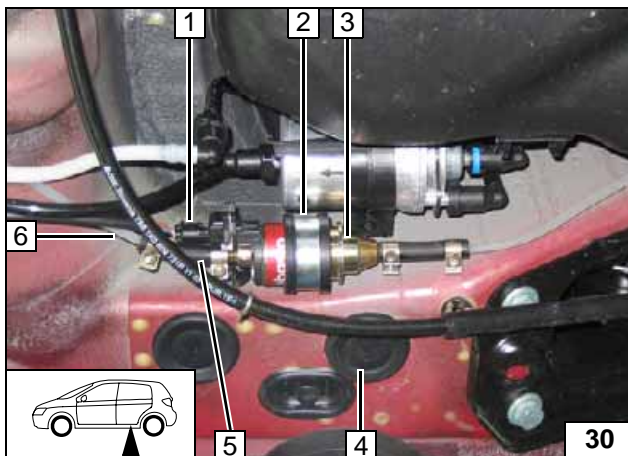

- 1 Wiring harness of metering pump, connector mounted
- 2 Secure rubber-coated p-clamp on silent block with flanged nut
- 3 Metering pump
- 4 Plug remounted
- 5 Hose section, 10 mm dia. clamp [2x]
- 6 Fuel line



Mounting metering pump and connecting pressure side

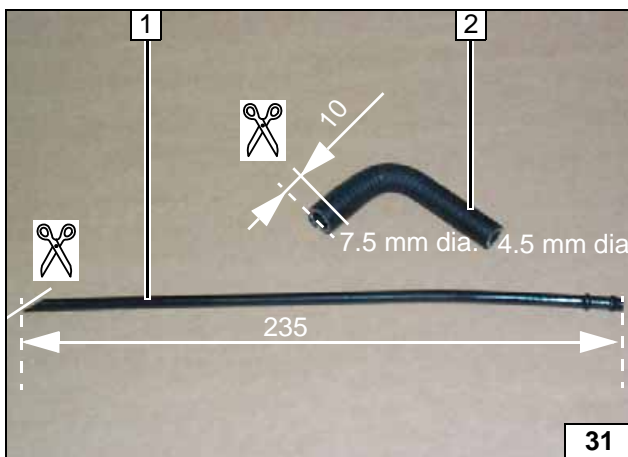

- 1 Standpipe
- 2 Molded hose

Cutting standpipe and molded hose to length



Clamp 2 in center between beads on end of standpipe.

- 1 Standpipe
- 2 10 mm dia. clamp
- 3 Molded hose



Premounting standpipe and molded hose

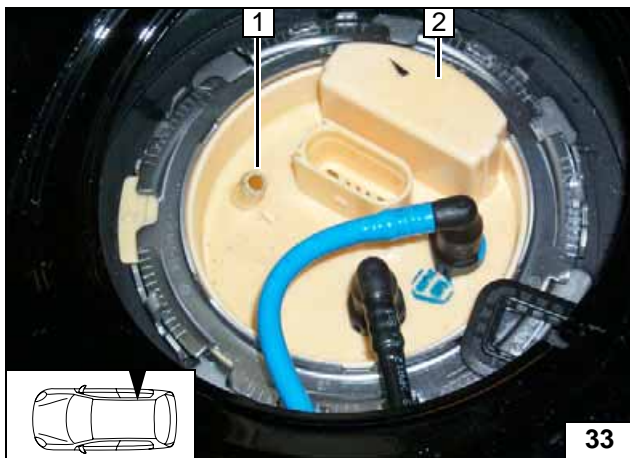

- 1 Tip of blind plug shortened by 3 mm
- 2 Fuel sender



Cutting off blind plug

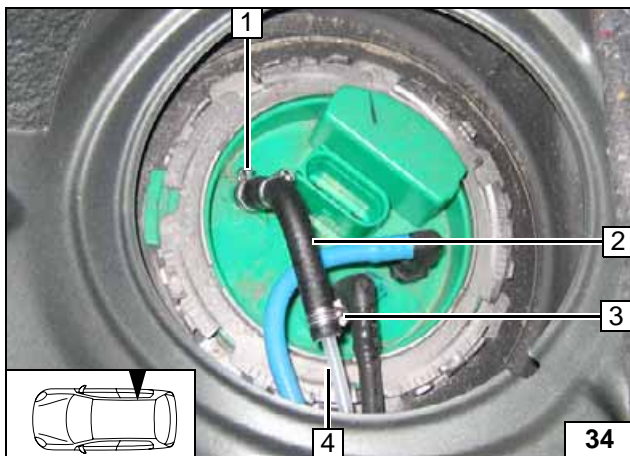

Should the standpipe be slightly curved on delivery, then it must be aligned so that the end points toward the rear right. Otherwise there is a danger of the fuel gauge being impaired.

- 1 13.5 mm dia. clamp
- 2 Preassembled molded hose with standpipe
- 3 10 mm dia. clamp
- 4 Remaining section of fuel line



Connection to fuel-tank sending unit

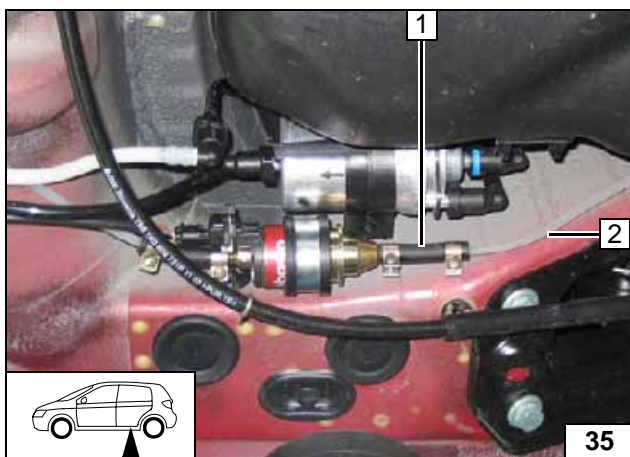

- 1 Hose section, 10 mm dia. clamp [2x]
- 2 Fuel line from fuel-tank sending unit



Connecting intake side of metering pump

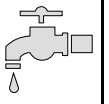

Coolant connection





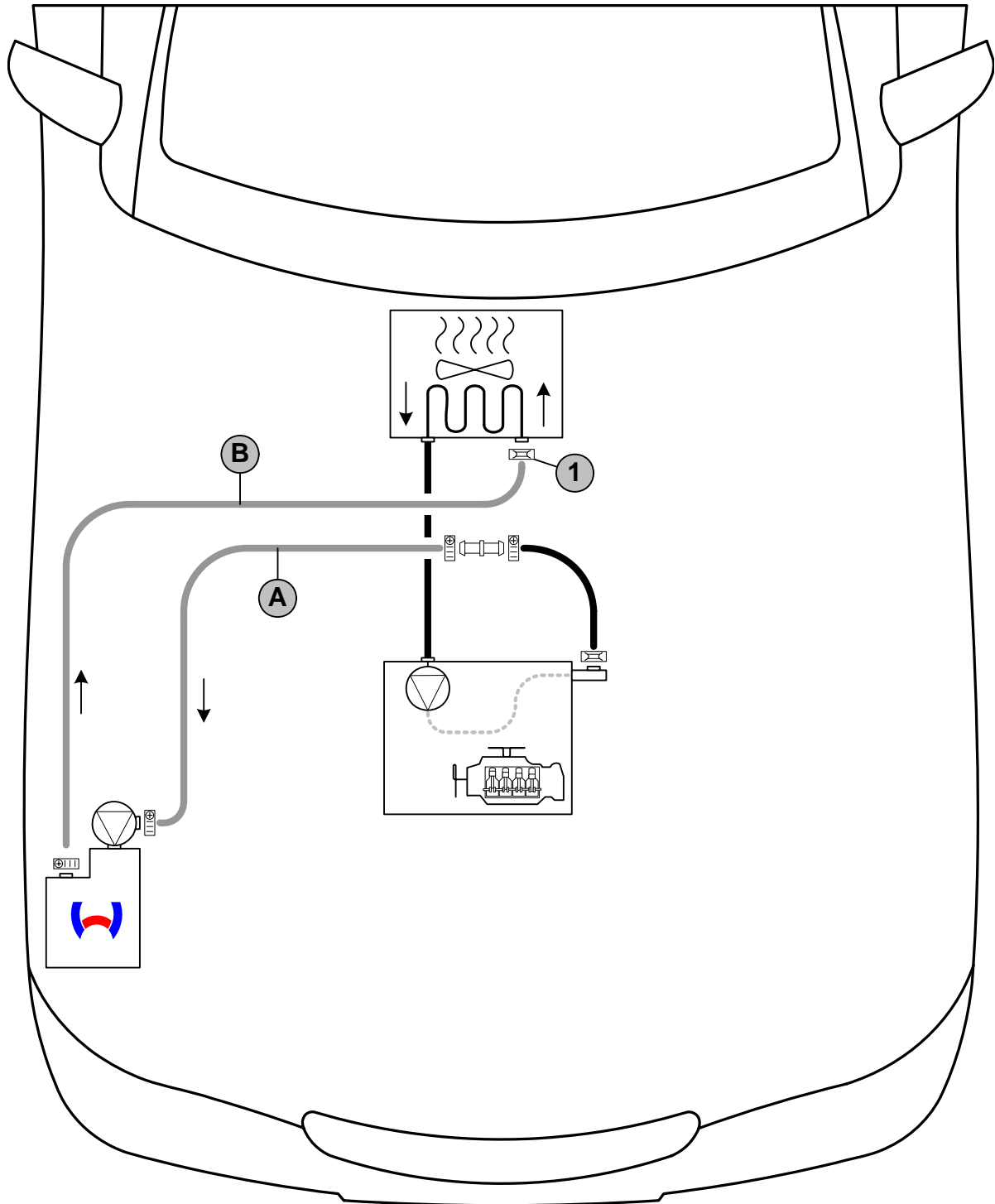

WARNING!

Any coolant running off should be collected using an appropriate container. Install hoses so that they are kink-free. Unless specified otherwise, always fasten using cable ties. Position clamps so that no other hose can be damaged! When installing the coolant hose, the heater unit must be filled with coolant.

The connection should be "inline" based on the following diagram:



Coolant routing diagram

1 = Original vehicle spring clip  .
 All hose clamps  = 20-27 mm dia.! Spring clip  = 27 mm dia.
 Connecting pipe  = 20x20 dia.



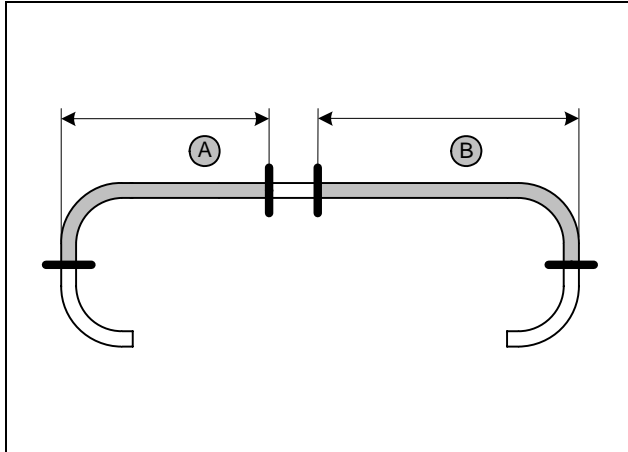

a = 970
b = 1020

Discard section X

Cutting coolant hoses to length

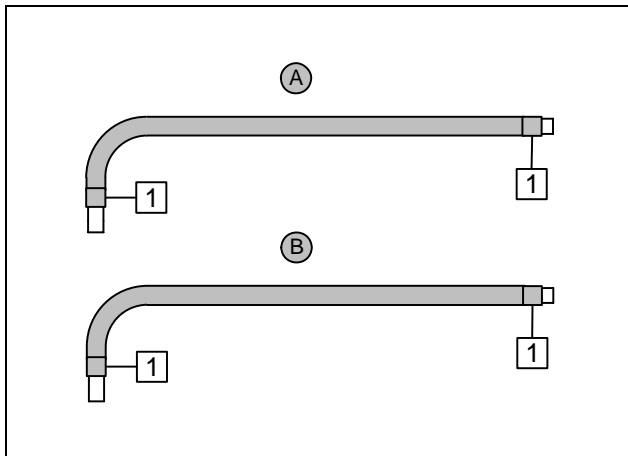

Push braided protection hoses onto hose A and B, cut to length and shrink.

1 Heat shrink plastic tubing [4x]



Preparing coolant hoses

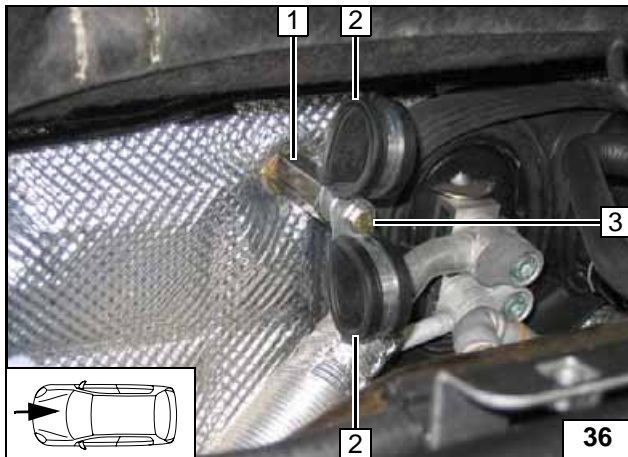

- 1 Large diameter washer, M6x40 spacer nut on original vehicle stud bolt
- 2 29 mm dia. rubber-coated p-clamp [2x]
- 3 M6x20 bolt, spring lockwasher

Preassembling fastener

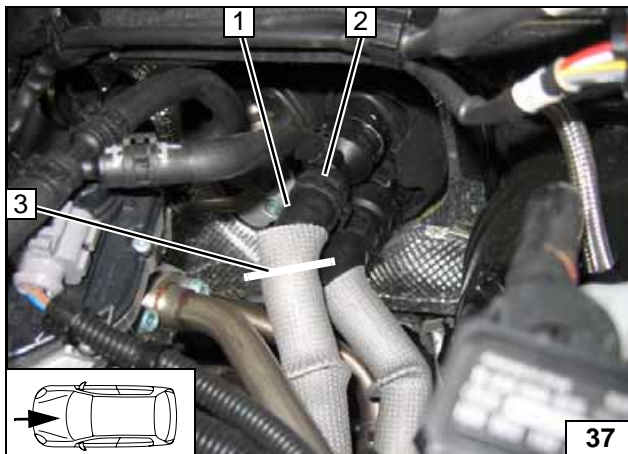

Pull off hose section 1 and discard. Spring clip 2 will be reused.

3 Cutting point



Cutting point

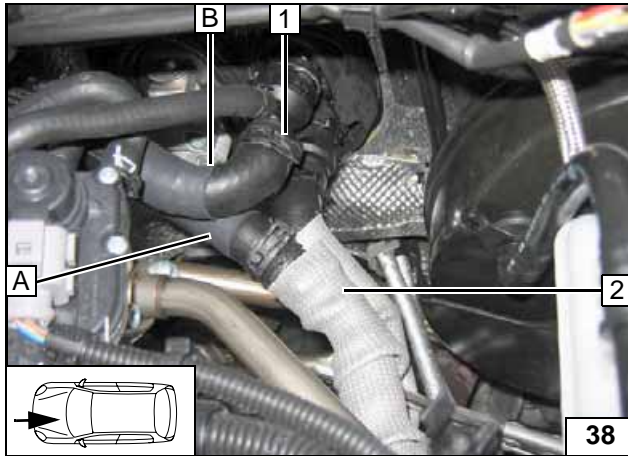
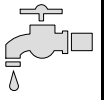

- 1 Original vehicle spring clip
- 2 Hose of engine outlet

Conne-
ction on en-
gine outlet
and heat
exchanger
inlet

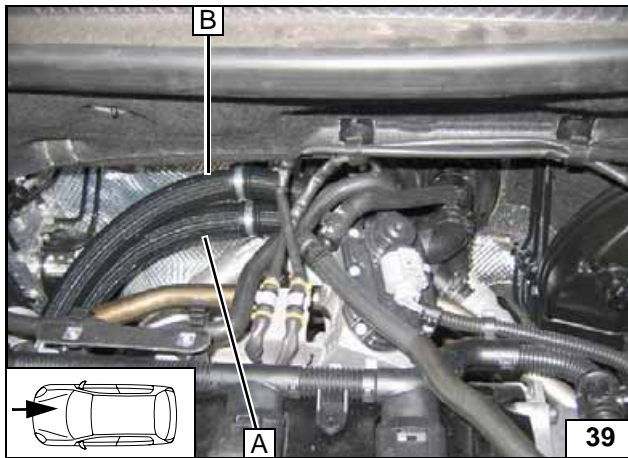

Hose
routing

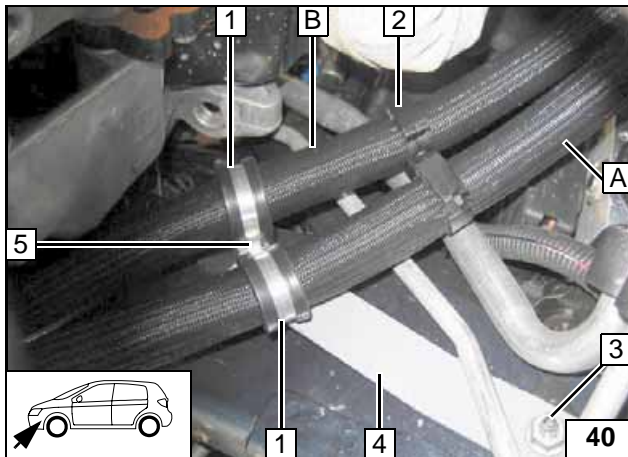

Ensure sufficient spacing between strut 4 and A/C lines.



- 1 Rubber-coated p-clamp [2x]
- 2 Hose bracket
- 3 Original vehicle nut
- 5 M6x20 bolt, flanged nut

Hose
routing

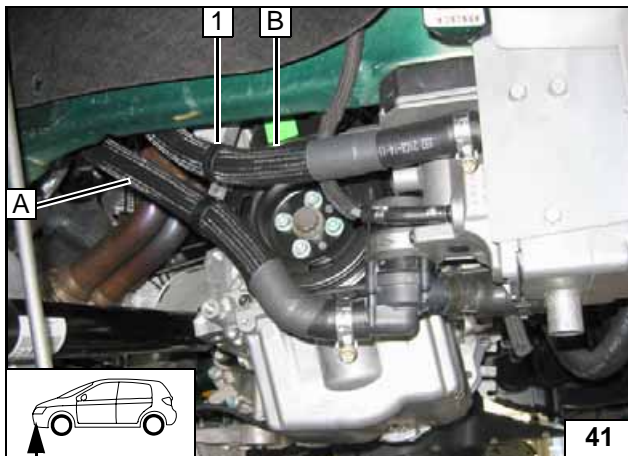

- 1 Hose bracket

Conne-
ction to
heater unit

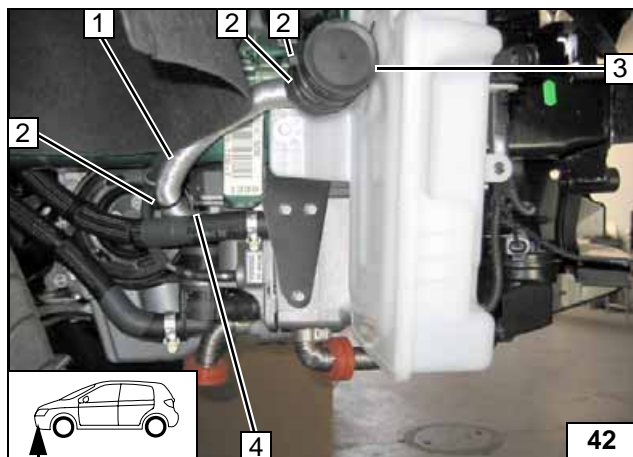

- 1 Intake pipe
- 2 Cable tie [3x]
- 3 Intake muffler
- 4 Hose clamp

Installing
muffler

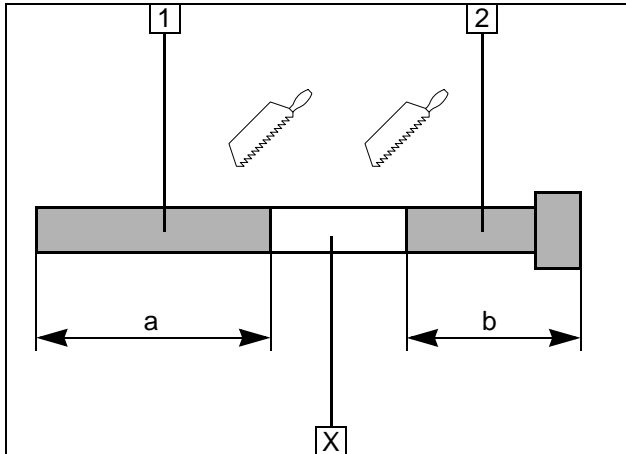
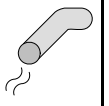

Exhaust gas

- 1 Exhaust pipe
a = 220
- 2 Exhaust end section
b = 115

Discard section X

Preparing exhaust pipe

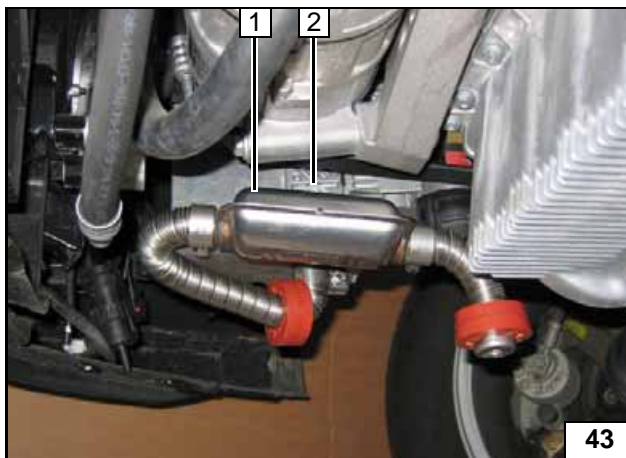

- 1 Exhaust muffler, M6x20 bolt, flanged nut
- 2 Angle bracket, Eject screw, large diameter washer

Installing muffler

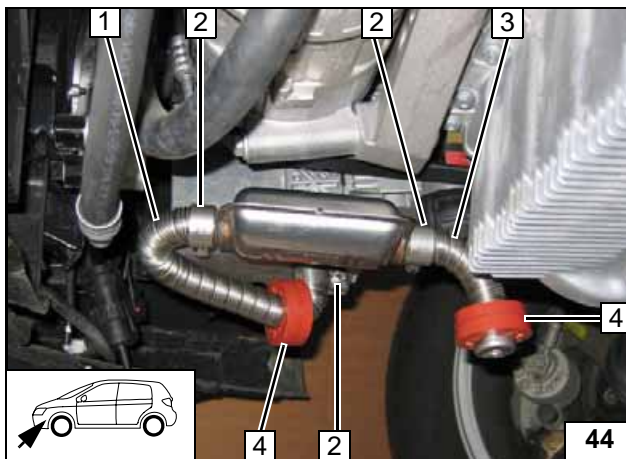

- 1 Exhaust pipe
- 2 Hose clamp [3x]
- 3 Exhaust end section
- 4 Red (rt) rubber profile [2x]

Installing exhaust pipe

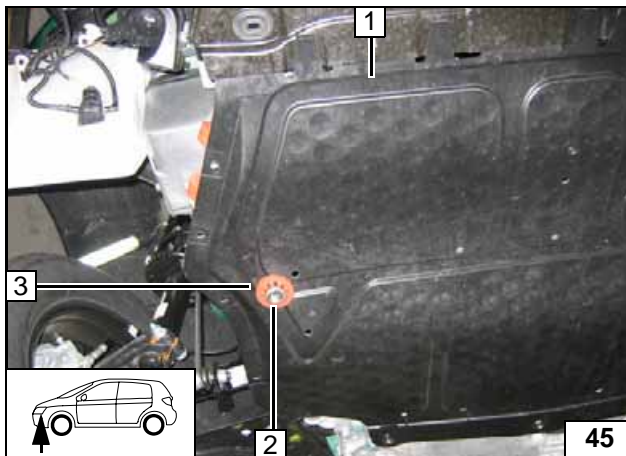

Drill 42 mm dia. hole in underide protection 1 at Position 2. Align exhaust end section 2 flush on red rubber isolator 3.



Mounting underide protection

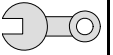

Final Work

WARNING!

Reassemble the disassembled components in reverse order.

Check all hoses, spring and Caillau clamps, as well as all electrical connections for firm seating.

Secure all loose cables using cable ties.

Spray heater unit components with anti-corrosion wax (Tectyl 100K, Order No. 111 329).

- Connect the battery
- Fill and bleed the coolant circuit according to the vehicle manufacturer's specifications.
- Set the digital timer.
- Adjust vehicle heater in accordance with "Operating Instructions for End Customer"
- Check the proper operation of the additional heater, see the operating instructions/installation instructions.
- File included vehicle-specific "Operating Instructions for End Customer" in vehicle logbook
- Attach the "Switch off additional heater before refueling" sticker to the left-hand B-pillar.



Adjust the sensitivity of the passenger compartment monitoring

WARNING!

This can only be carried out at an authorized workshop! Observe the applicable repair manual of the respective vehicle.

- Connect the VAS tester.
- Open Item 46 (Central Module of Comfort System)
- Go to Item 10 (Adjustment)
- Follow the request for the code entry and enter the code 15
- Reduce the sensitivity of the passenger compartment monitoring to 50 %
- Save this setting
- The adjustment of the sensitivity of the passenger compartment monitoring is completed.

Operating Instructions for End Customer

Please remove page and add to the vehicle operating instructions.



Note:

We recommend matching the heating time to the driving time.

Heating time = driving time

Example:

For a driving time of approx. 20 min. (in one direction), we recommend not exceeding a switch-on time of 20 min.

If the summer/winter switch option has been installed, this must be switched in accordance with the time of year. The heater unit will then only switch on the vehicle fan to ventilate the vehicle interior in the position Winter  heat and in the position Summer .

Before parking the vehicle, make the following settings:



- 1 Set temperature to "max."
- 2 Air outlet to windshield
- 3 Set fan to level "1", or possibly "2"



- 1 Set temperature to „HI.“ [2x]



Climatic

Clima-tronic