

K Installation documentation

for Thermo Top Evo water heater

Citroen C4 Cactus

Left-hand drive vehicle

Manufacturer	Model	Type	Model year	EG-BE-No. / ABE		
Citroen	C4 Cactus	0	from 2018	e2* 2007/46* 0440*...		
Motorisation	Fuel	Emission standard	Transmission type	Out-put[kW]	Displace-ment[cm ³]	Engine code
1.2P	Petrol	Euro 6	6-speed SG	81	1199	HNZB
1.2P	Petrol	Euro 6	6-speed SG	96	1199	HNZB

Validity	Equipment variants	Model
		C4 Cactus
Verified equipment variants	3 zone automatic air-conditioning	X
	Halogen main headlights	X
	Halogen front fog lights	X
	LED daytime running lights	X
	Automatic Start-Stop system	X
Unverified equipment variants	Manual air-conditioning	X
	Keyless Go	X

Total installation time	Note
10.0 hours	

Contents

1	List of abbreviations	3	14	Electrical system of passenger compartment	42
2	Installation notes	4	14.1	Passenger compartment dismantling instructions	42
2.1	Information on Validity	4	14.2	Electrical system preparation	44
2.2	Components used	4	14.3	Wiring diagram	47
2.3	Information on Total Installation Time	4	14.4	Fan controller	49
2.4	Installation Recommendations	4	15	Electrical system of control elements	52
3	About this document	5	15.1	Telestart option	52
3.1	Purpose of the document	5	15.2	ThermoCall option	53
3.2	Warranty and liability	5	16	Final Work	54
3.3	Safety	5	17	Bracket A template	57
3.4	Using this document	6	18	Bracket B template	59
4	Technical Information	7	19	FuelFix template	61
5	Preparing measures	8	20	Operating instructions	63
5.1	Vehicle preparation	8	20.1	A/C control panel settings	63
5.2	Heater preparation	8	20.2	Installation location of fuses	63
6	Installation overview	9			
7	Electrical system of engine compartment	10			
8	Mechanical system	13			
8.1	Preparing installation location	13			
8.2	Premounting heater	14			
8.3	Heater mounting	16			
9	Fuel	18			
9.1	Routing fuel line	18			
9.2	Installing FuelFix	21			
9.3	Fuel pump connection	25			
10	Coolant	26			
10.1	Hose routing diagram	26			
10.2	Coolant circuit installation	27			
11	Combustion air	34			
12	Exhaust	36			
13	Final work in engine compartment	39			

1 List of abbreviations

DP	Fuel pump
EFIX	Exhaust end fastener
EPT	Telestart receiver
FF	FuelFix (tank extracting device)
Fig.	Figure
HG	Heater
K2	Additional relay
PWM	Pulse width modulator
RSH	Relay and fuse holder of passenger compartment
SG	Manual transmission
SH2	Engine compartment fuse holder for F1/F2
UP	Coolant pump
Wire	Cable

2 Installation notes

2.1 Information on Validity

This installation documentation applies to vehicles listed on page 1, assuming technical modifications to the vehicle do not affect installation, any liability claims excluded. Depending on the vehicle version and equipment, modifications may be necessary during installation with respect to this installation documentation. Vehicle and engine types, equipment variants and other specifications not listed in this installation documentation have not been tested. However, installation according to this installation documentation may be possible.

2.2 Components used

Designation	Order number
Basic delivery scope of Thermo Top Evo	In accordance with price list
Installation kit for Citroen C4 Cactus petrol	1326788A
In case of control element as well as Telestart indicator lamp in consultation with end customer	In accordance with price list

2.3 Information on Total Installation Time

The total installation time includes the time needed for mounting and demounting the vehicle-specific components, the heater specific installation time and all other times required for the system integration and initial start-up of the heater.

The total installation time may vary for vehicle equipment other than provided.

2.4 Installation Recommendations

Arrange for the vehicle to be delivered with the tank only about $\frac{1}{4}$ full.

For the MultiControl CAR option, the recommended installation locations for the Telestart or ThermoCall push button should be confirmed with the end customer.

Depending on the space required and the vehicle manufacturer's instructions, we recommend the use of a vehicle battery with a higher electrical capacity.

We recommend installing a Thermo Top Evo 4. The heater is integrated into the coolant circuit as an 'island' and heats up the vehicle passenger compartment. There is no engine pre-heating.

3 About this document

3.1 Purpose of the document

This installation documentation is part of the product and contains all the information required to ensure professional vehicle specific installation of the:

Thermo Top Evo heater

3.2 Warranty and liability

Webasto shall assume no liability for defects, damage and injuries resulting from a failure to observe the installation, repair and operating instructions of the information contained in them.

This liability exclusion particularly applies to improper installations and repairs by untrained persons or in the case of a failure to use genuine spare parts.

The liability due to culpable disregard to life, limb or health and due to damage or injuries caused by a wilful or reckless breach of duty remain unaffected, as does the obligatory product liability.

Installation should be carried out according to the general, standard rules of technology. Unless specified otherwise, fasten hoses, lines and wiring harnesses to original vehicle lines and wiring harnesses using cable ties. Insulate loose wire ends and tie back. Connectors on electronic components must audibly snap into place during assembly.

Spray unfinished body areas, e.g. drilled holes, with anti-corrosion wax (Tectyl 100K).

Observe the instructions and guidelines of the respective vehicle manufacturer for demounting and mounting vehicle specific components.

The initial start-up is to be executed with the Webasto Thermo Test Diagnosis.

When installing a programmable control module (e.g. a PWM Gateway), the corresponding settings must be checked or adjusted.

3.2.1 Statutory regulations governing installation

The Thermo Top Evo heater has been type-tested and approved in accordance with ECE-R 10 (EMC) and ECE-R 122 (heater). The regulations of these guidelines are binding in the scope of the Directive 70/156/EEC and/or 2007/46/EC (for new vehicle models from 29/04/2009) and should also be observed in countries in which there are no special regulations.

The heater is licensed in accordance with paragraph 19, section 3, No. 2b of the StVZO (German Road Traffic Licensing Authority).

3.3 Safety

Qualifications of installation personnel

The installation personnel must have the following qualifications:

- Successful completion of Webasto training
- Corresponding qualification for working on technical systems

Regulations and legal requirements

The regulations from the heater's general installation and operating instructions must be observed.

3.3.1 Safety information on installation

Danger posed by live parts

- ▶ Prior to installation, disconnect the vehicle from the voltage supply.
- ▶ Make sure the electrical system is earthed correctly.
- ▶ Always comply with legal requirements.
- ▶ Observe data on type label.

Danger of fire and leaking toxic gases due to improper installation

- ▶ Vehicle parts in the vicinity of the heater must be protected against excessive heating by the following measures:
 - ⇒ Maintain minimum safety distances.
 - ⇒ Ensure adequate ventilation.
 - ⇒ Use fire-resistant materials or heat shields.

Danger due to sharp edges

- Lacerations
- Short circuit due to electrical wire damage
- ▶ Fit protectors on sharp edges.

3.4 Using this document

Before installing and operating the heater, read this installation documentation, the installation instructions of the heater, the operating instructions and supplementary sheets provided.

3.4.1 Explanatory Notes on the Document

There is an identification mark near the respective work step to allow you to quickly allocate the other applicable documents to the Webasto components to be installed:

Generally valid Webasto documentation	
Vehicle-specific installation documentation	
Webasto Comfort A/C control	
Webasto Standard A/C control	
Tank extracting device (e.g. FuelFix)	
Exhaust end fastener (EFIX)	
Combustion air intake silencer	
Spacer bracket (ASH)	

3.4.2 Use of symbols



DANGER

Type and source of the risk

Consequences: Failure to follow the instructions can result in death

► Actions to protect yourself against risks.



WARNING

Type and source of the risk

Consequences: Failure to follow the instructions can lead to serious or even fatal injuries

► Actions to protect yourself against risks.



CAUTION

Type and source of the risk

Consequences: Failure to follow the instructions can lead to minor injuries

► Actions to protect yourself against risks.



Type and source of the risk

Consequences: Failure to follow the instructions can lead to material damage

► Actions to protect yourself against risks.



Reference to the vehicle manufacturer's specific documents.



a note on a special technical feature

3.4.3 Work step identification marks

The ongoing work step is indicated on the outside top corner of the page:

Mechanical system	Electrical System	High-voltage	Coolant
Combustion air	Fuel	Exhaust gas	Software

3.4.4 Orientation aid

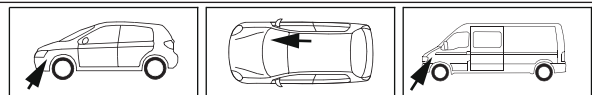

The arrow indicates the position on the vehicle and the viewing angle

3.4.5 Use of highlighting

Highlight	Explanation
►	Necessary action
⇒	Result of an action
1 / 12 / a1 / A	Position numbers for the image descriptions
① / ⑫	Position numbers for the image descriptions for electrical wires and wiring harnesses and coolant hose sections

4 Technical Information

Dimension specifications

- All dimensions specified in mm

Tightening torque specifications

- Tightening torque values of 5x13 heater bolts and 5x11 heater stud bolts = 8Nm
- Tightening torque values of 5x15 retaining plate of water connection piece bolts = 7Nm
- 5x12 bolt tightening torque of 2-part heater bracket = 6Nm
- Tighten other bolt connections in accordance with manufacturer's instructions or in accordance with state-of-the-art-technology

Specified temperature for fabric heat shrink tubing

- Shrink temperature max. 230°C

Necessary special tools

- Hose clamp pliers for self-clamping hose clamps
- Hose clamp pliers for Clic hose clamps of type W
- Hose clamping pliers
- Hose cutter
- Automatic wire stripper 0.2 - 6 mm²
- Crimping pliers for cable lugs 0.5 – 10 mm²
- Crimping pliers for tab connector 0.14 – 6 mm²
- Crimping pliers for connector 0.25 – 6 mm²
- Torque wrench for 2.0 - 10 Nm
- Deep-hole marker
- Metric thread-setter kit
- Webasto Thermo Test Diagnosis with current software

5 Preparing measures

5.1 Vehicle preparation



Further information can be found in the vehicle manufacturer's technical documentation.

- ▶ Open the fuel tank cap
- ▶ Ventilate the fuel tank
- ▶ Close the fuel tank cap again
- ▶ Depressurise the cooling system
- ▶ Disconnect the battery and remove it completely with the battery carrier
- ▶ Remove the left front wheel
- ▶ Remove the left wheel well trim
- ▶ Detach the wheel well trim in the front part on the right
- ▶ Disconnect the Bowden cable for the bonnet release from the lock
- ▶ Remove the daytime running lights on the right and left
- ▶ Remove the left headlight
- ▶ Remove the bumper trim
- ▶ Detach the rear bench seat (attached with clips)
- ▶ Remove the lower instrument panel trim on the driver's side
- ▶ Remove the side trim of the centre console on the driver's side
- ▶ Open the tank fitting service lid on the left

5.2 Heater preparation



Observe the general installation instructions of the heater.

- ▶ Remove years that do not apply from the type and duplicate label.
- ▶ Attach the duplicate label (type label) in the appropriate place in the engine compartment.

6 Installation overview

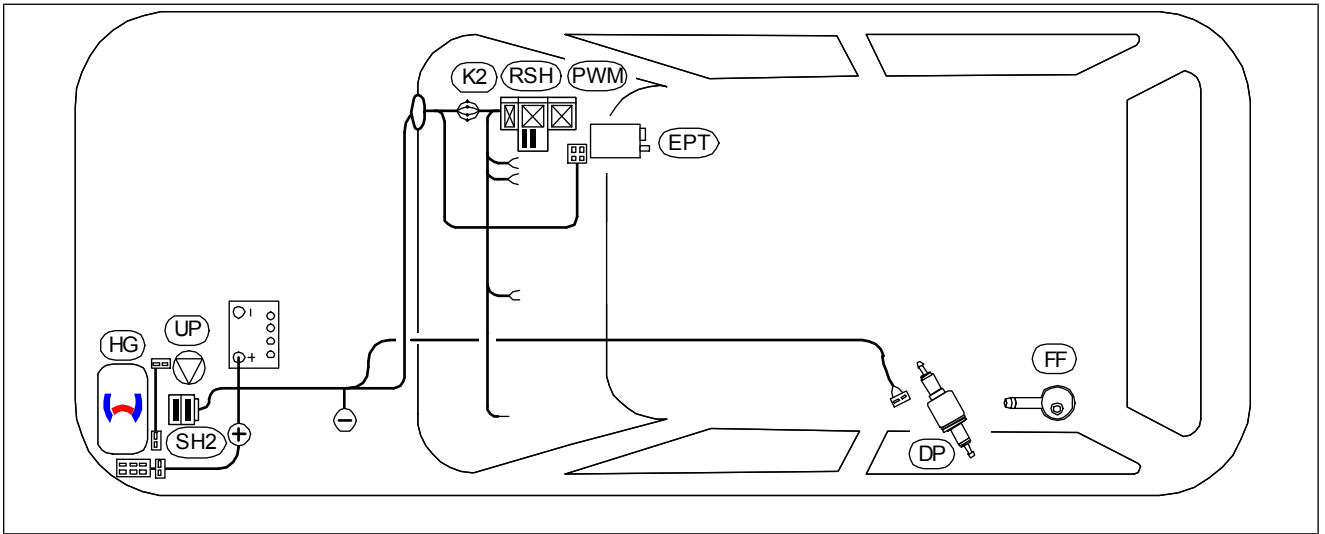

Fig. 1

Legend to installation overview

Abbreviation	Component
DP	Fuel pump
EPT	Telestart receiver
FF	FuelFix
HG	Heater
K2	Relay K2
PWM	Pulse width modulator
RSH	Relay and fuse holder of passenger compartment
SH2	Engine compartment fuse holder for F1/F2
UP	Coolant pump

Heater installation location



Fig. 2

1 Heater



7 Electrical system of engine compartment

Drilling hole

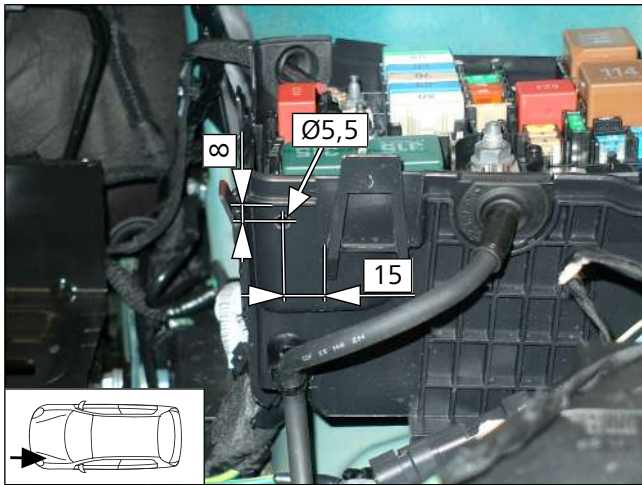

Fig. 3



Danger of damage to the electrical components

- ▶ When drilling, be careful of components located behind.

Mounting SH2



Fig. 4

- 1 M5x16 bolt, large diameter washer, SH2 retaining plate, large diameter washer, nut
- 2 Fuses F1 and F2

Earth wire connection

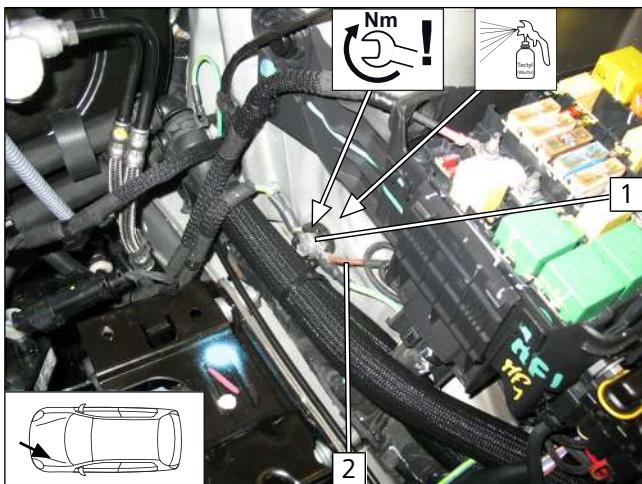

Fig. 5



DANGER

Fire hazard due to insufficient tightening torque

- ▶ Observe tightening torque

- 1 Original vehicle earth point
- 2 Earth wire



Positive wire connection

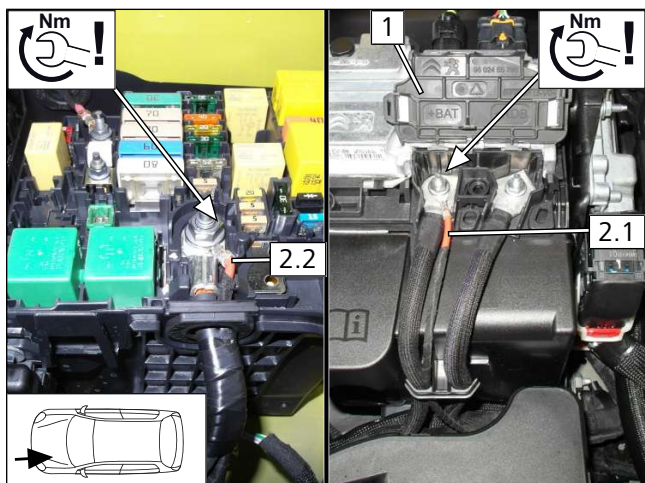

Fig. 6



DANGER

Fire hazard due to insufficient tightening torque

► Observe tightening torque

- 1 Control unit
- 2.1 Positive wire on positive battery terminal, if control unit is present on battery
- 2.2 Positive wire on original vehicle positive distributor, if control unit is not present on battery

Wiring harness routing in engine compartment

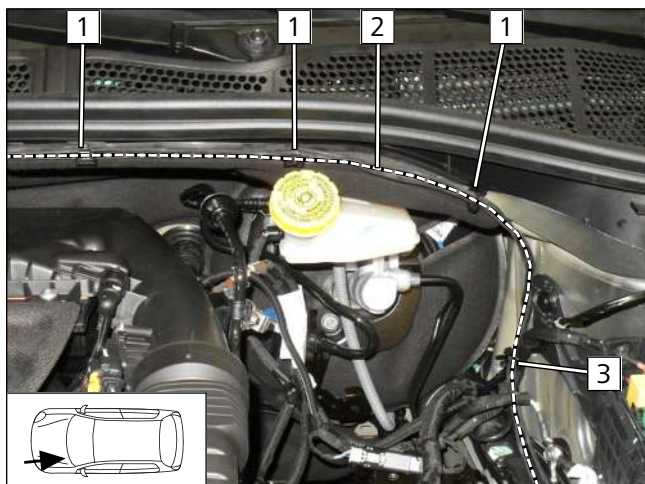

Fig. 7

- 1 Edge clip cable tie on edge of coolant reservoir
- 2 Heater and control element wiring harness
- 3 Cable tie around original vehicle wiring harness

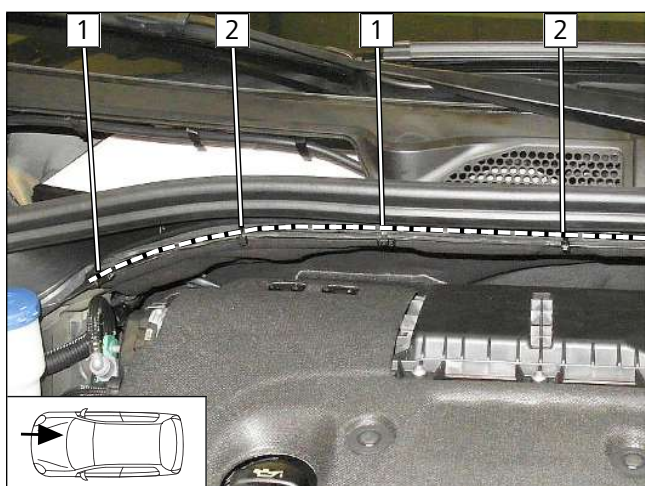
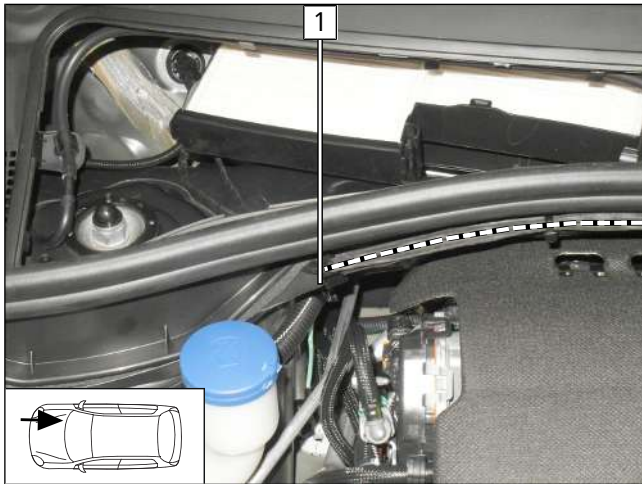

Fig. 8

- 1 Edge clip cable tie on edge of coolant reservoir
- 2 Cable tie



► Route heater wiring harness at pos **1** into coolant reservoir.

Fig. 9

Passenger compartment wiring harness pass through

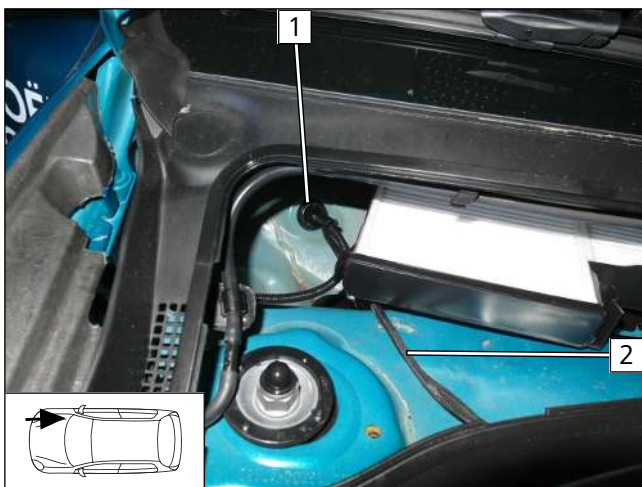

- 1** Protective rubber plug
- 2** Heater and control element wiring harness

Fig. 10



8 Mechanical system

8.1 Preparing installation location

Removing control unit

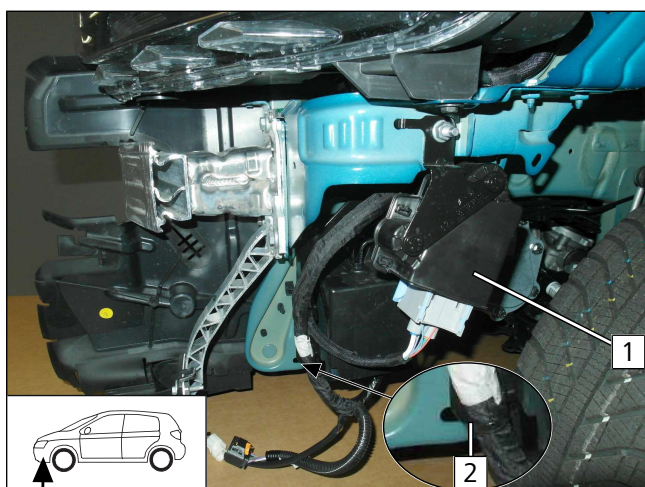

Fig. 11

- ▶ Remove control unit **1** with bracket.
- ▶ Detach clip-type cable tie **2** and open carefully, will be reused.

Mounting angle bracket, insulating original vehicle wiring harness

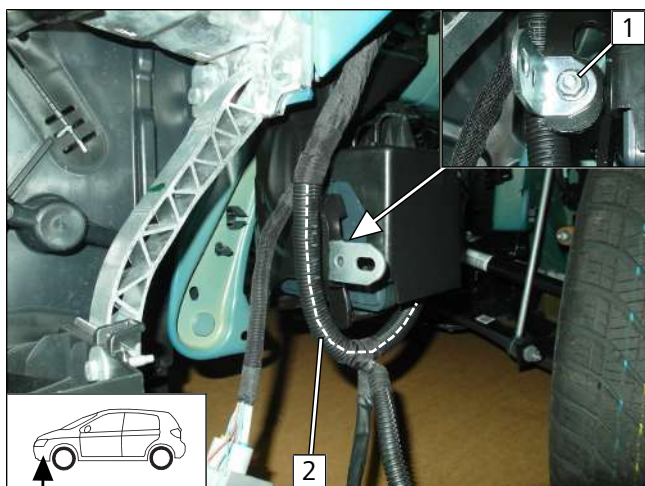

Fig. 12

- ▶ Attach angle bracket to the top position of the original vehicle oblong hole.
- ▶ Insulate the marked section of original vehicle wiring harness **2** using a corrugated tube.

1 M6x16 bolt, large diameter washer, original vehicle oblong hole, angle bracket, flanged nut

Fastening original vehicle wiring harness

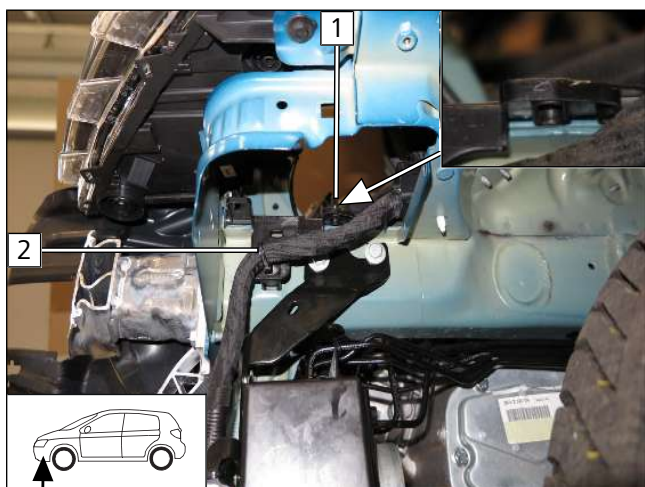

Fig. 13

- ▶ Cut off plastic clip **1** flush.
- ▶ Attach wiring harness using available hole and original vehicle clip-type cable tie **2**.



Fig. 14

- 1 Original vehicle clip-type cable tie
- 2 Edge clip cable tie
- 3 Cable tie

Drilling hole, mounting spacer nut

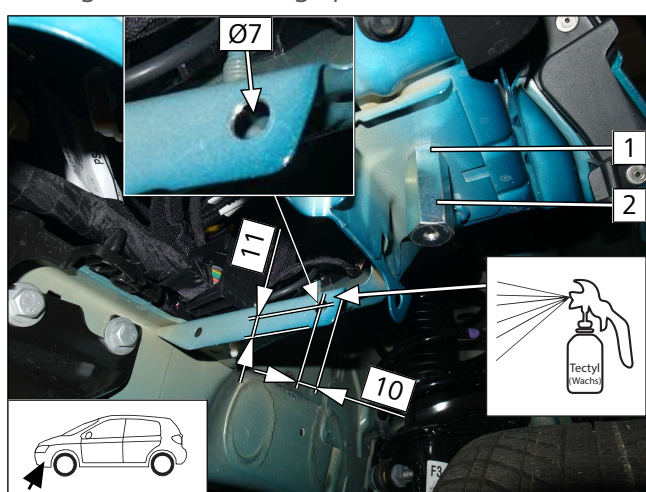

Fig. 15

- Remove original vehicle bolt at pos. 1 and discard.
- 2 M6x20 bolt, spring lockwasher, large diameter washer, original vehicle hole, 40 spacer nut

8.2 Premounting heater

Mounting water connection piece

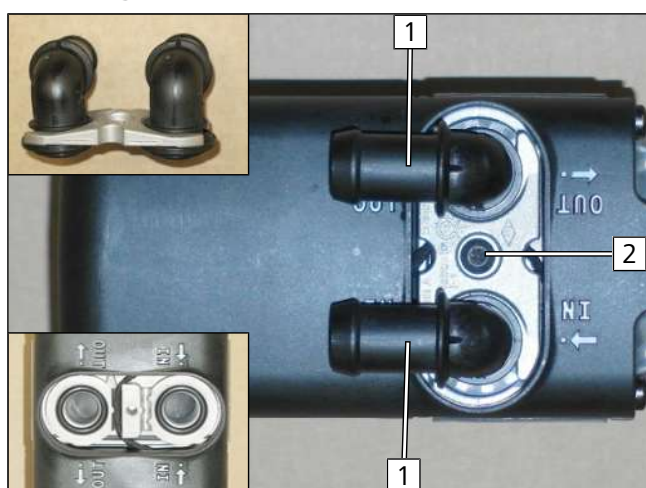

Fig. 16



Observe the general installation instructions of the heater.

- 1 Water connection piece, seal
- 2 5x15 self-tapping bolt, water connection piece retaining plate



Mounting bracket **A** onto heater

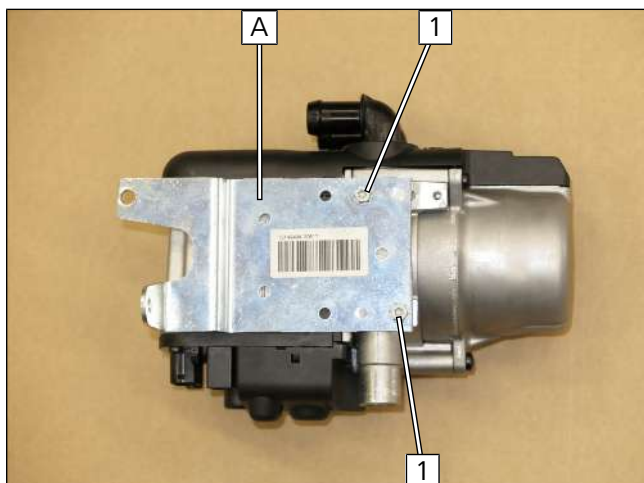

Fig. 17

► Prepare bracket **A** in accordance with template.

- 1** 5x13 self-tapping bolt

Mounting bracket **B** onto heater

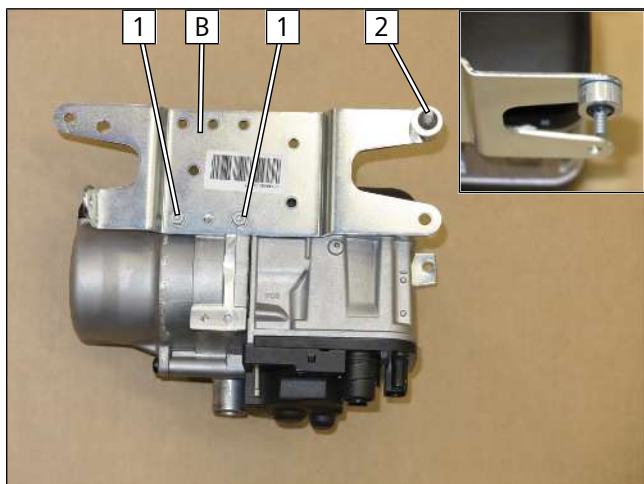

Fig. 18

► Prepare bracket **B** in accordance with template.

- 1** 5x13 self-tapping bolt
- 2** M6x25 bolt, bracket **B**, 10mm shim, lock washer

Cutting hoses to length

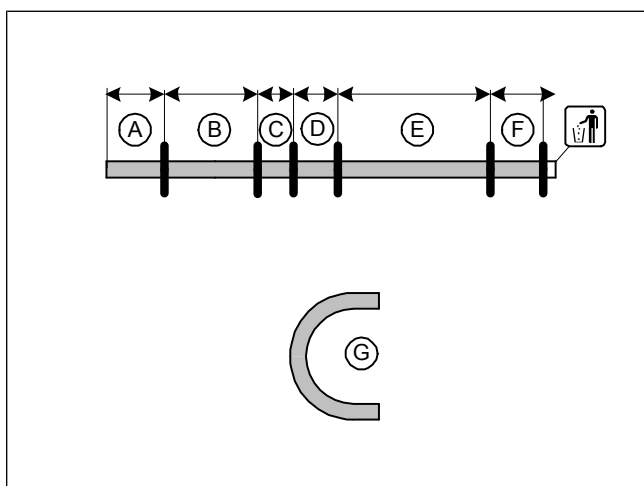

Fig. 19

A	250
B	500
C	90
D	130
E	750
F	260
G	180°



Preparing hoses

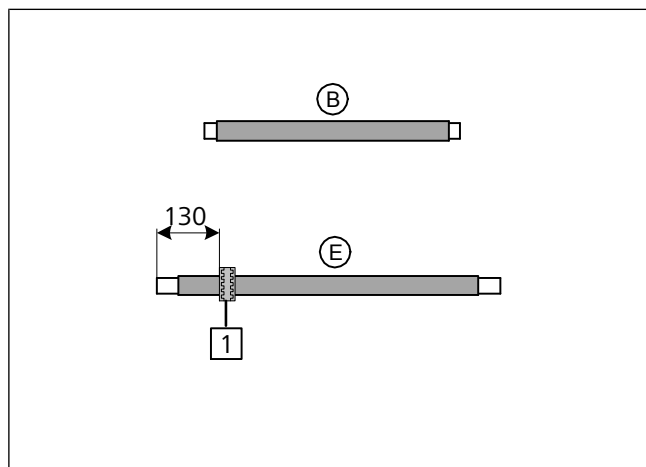

Fig. 20

► Slide fabric heat shrink tubings onto hoses **B** and **E**, cut to length and shrink.

- 1 Black rubber isolator

Mounting hoses

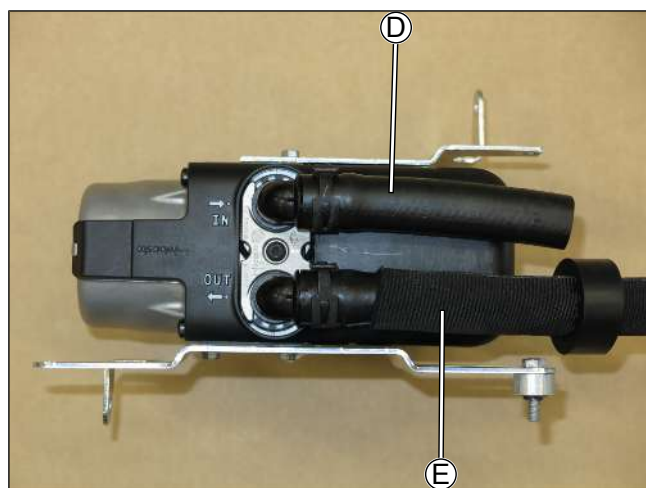

Fig. 21



All spring clips, 25mm dia.

8.3 Heater mounting

Mounting bracket **B**

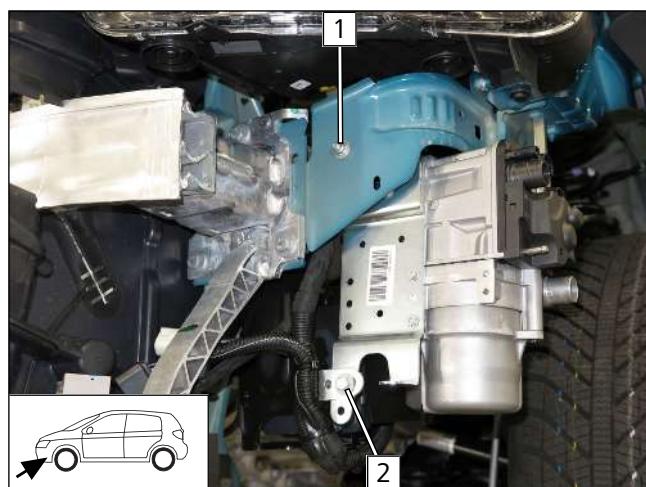

Fig. 22

- 1 Bolt in bracket **B**, original vehicle hole, large diameter washer, M6 flanged nut
- 2 M6x16 bolt, large diameter washer, angle bracket, bracket **B**, large diameter washer, flanged nut



Mounting bracket **A**

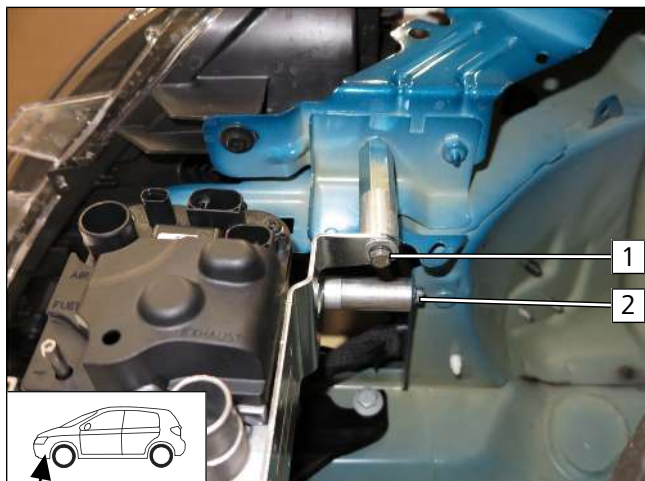

Fig. 23

- 1 M6x50 bolt, spring lockwasher, large diameter washer, bracket **A**, 30mm shim on spacer nut
- 2 M6x60 bolt, bracket **A**, 10mm shim, 40mm shim, drilled hole, flanged nut

Mounting heater wiring harness

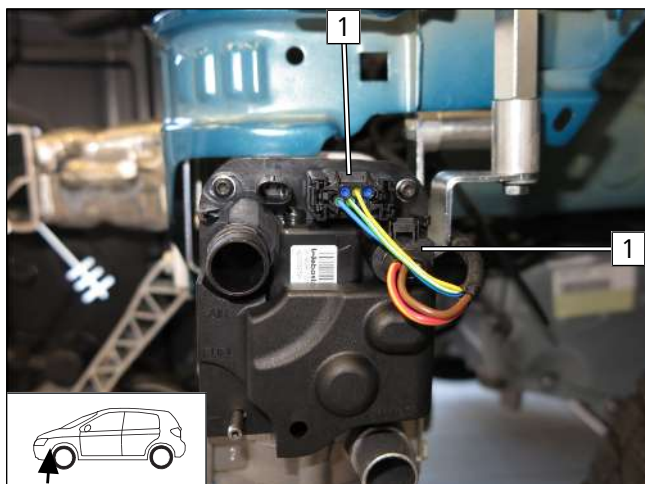

Fig. 24

- 1 Heater wiring harness connector



9 Fuel



DANGER

Risk of fire and explosion due to leaking fuel and escaping fuel vapours.

The Incorrect installation of the fuel extractor can cause damage and fire.

- ▶ Avoid electrostatic discharges and open fire.
- ▶ When working on the fuel system, ensure sufficient ventilation and bleeding.
- ▶ Open the fuel tank cap of the vehicle.
- ▶ Ventilate the fuel tank
- ▶ Re-close the tank lock.
- ▶ Catch any fuel running off with an appropriate container.



Danger of damage to components

- ▶ Install fuel line and fuel pump wiring harness so that they are protected against stone impact.
- ▶ Provide rub protection for fuel line and wiring harness in areas where there are sharp edges.

Dismantling fuel pump connector X7

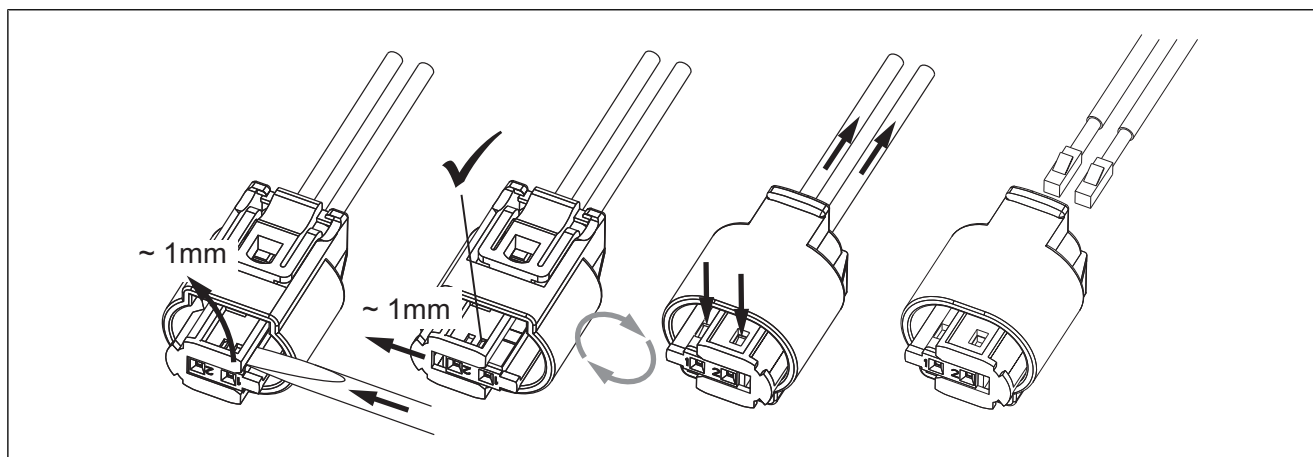

Fig. 25

9.1 Routing fuel line

Connection to heater

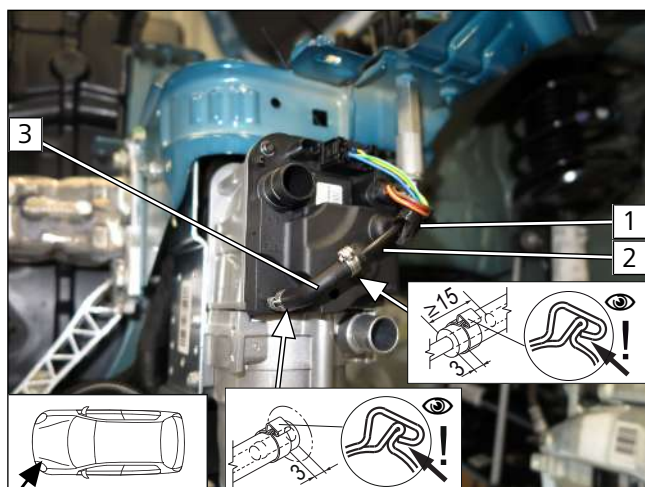

Fig. 26

- ▶ Draw fuel line **2** and fuel pump wiring harness into 10mm dia corrugated tube **1** and route into the engine compartment.

- 3** 90° moulded hose, 10mm dia. clamp [2x]



Routing line

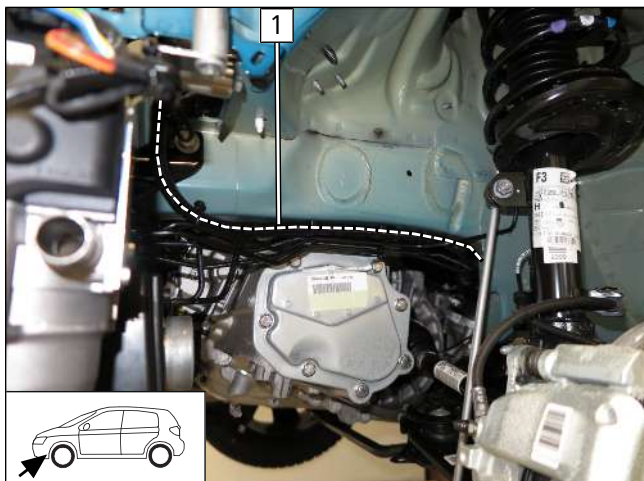

Fig. 27

- ▶ Route corrugated tube **1** with fuel line and fuel pump wiring harness in the engine compartment on the original vehicle brake line to the underbody.



Fig. 28

- ▶ Route fuel line and fuel pump wiring harness in corrugated tube **1** on the original vehicle lines to the installation location of the fuel pump.

Inserting rivet nut

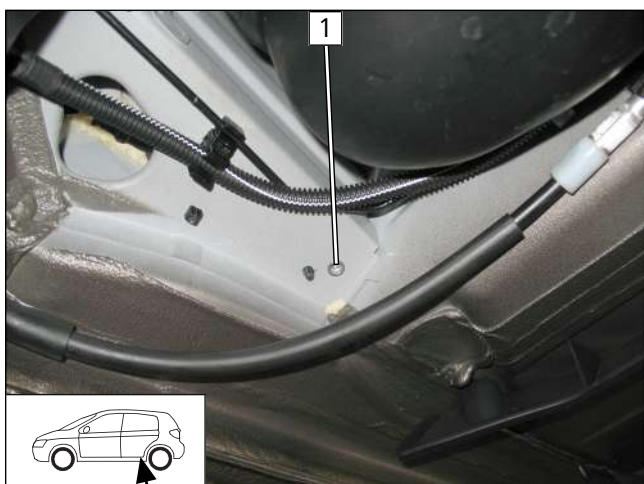

Fig. 29

- 1** Original vehicle hole, M6 rivet nut



Mounting fuel pump



Fig. 30

- 1 Fuel pump
- 2 M6x25 bolt, support angle bracket, fuel pump mount on rivet nut

Mounting fuel pump connector X7

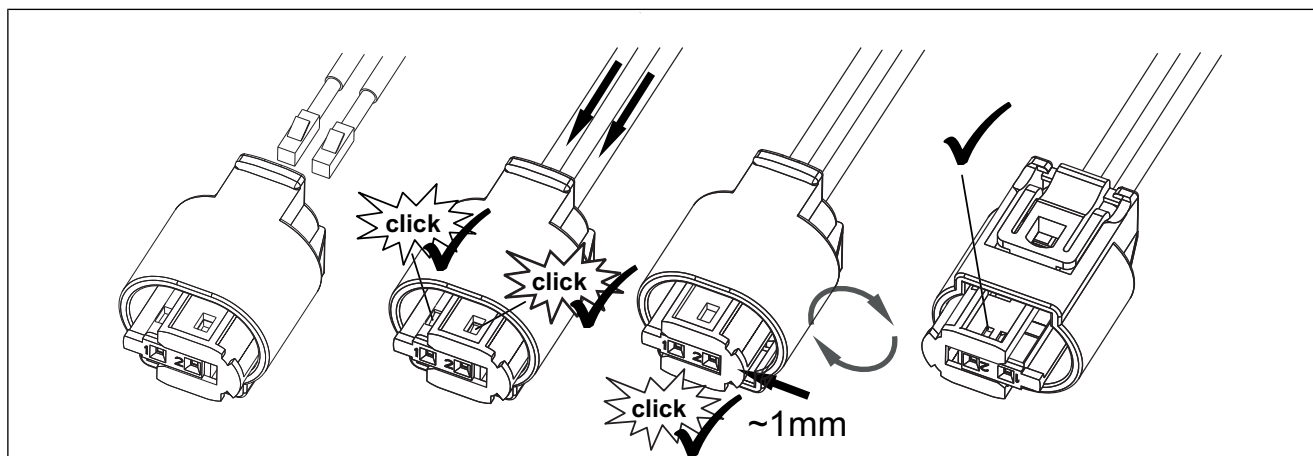

Fig. 31

Connecting fuel pump

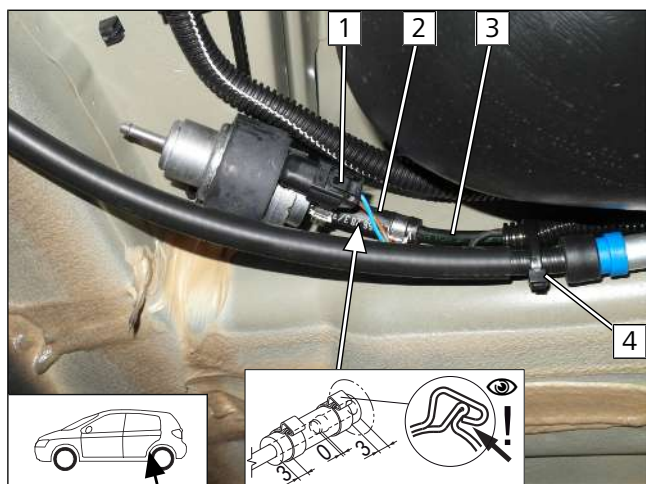

Fig. 32

- 1 Fuel pump wiring harness, connector X7 mounted
- 2 Hose section, 10mm dia. clamp [2x]
- 3 Heater fuel line
- 4 Cable tie



9.2 Installing FuelFix

Preparing drilling template

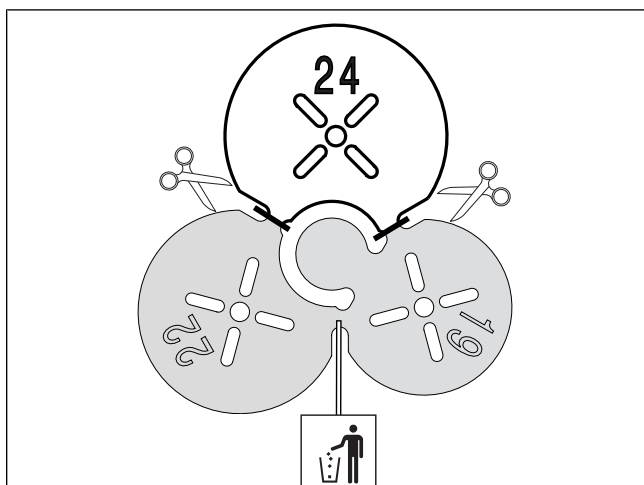

Fig. 33

Copying hole pattern

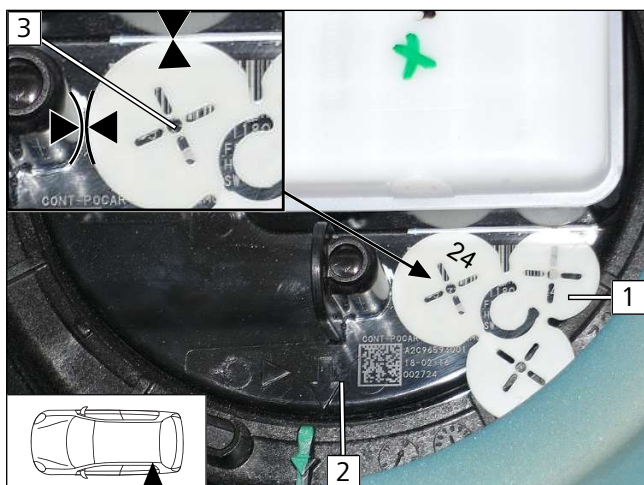

Fig. 34

Hole for FuelFix

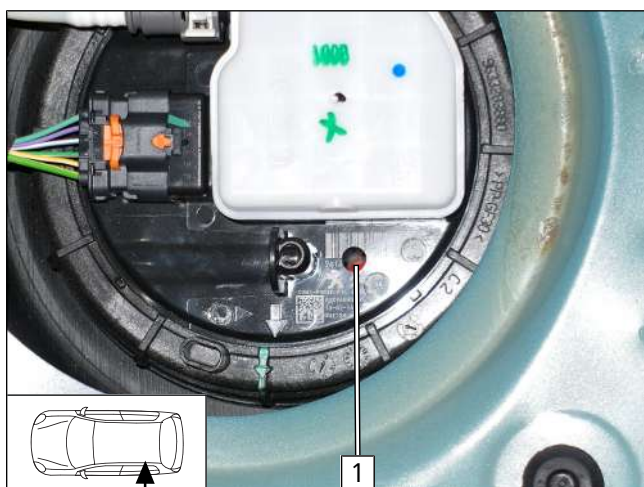

Fig. 35



Observe the installation instructions of the tank extracting device.

► Work steps F1, F2

- 1 Position 24mm dia. drilling template as shown in fig.
- 2 Tank fitting
- 3 Hole pattern



DANGER

Risk of fire and explosion due to leaking fuel and escaping fuel vapours.

► Work step F3

- 1 Hole made with provided drill



Inserting FuelFix

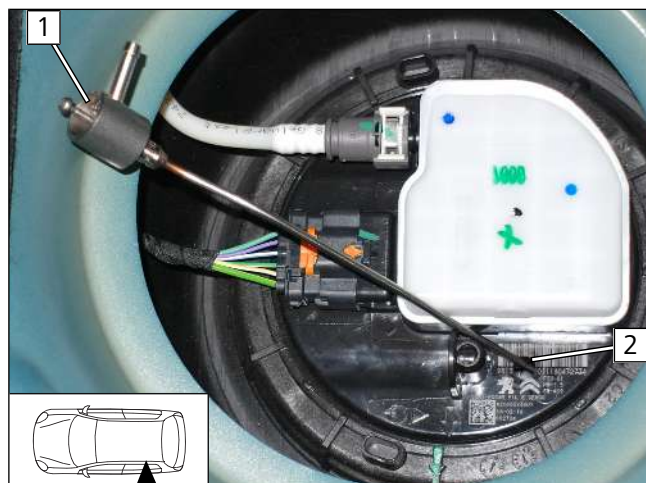

Fig. 36

- ▶ Work steps F4, F5
- ▶ Bend FuelFix **1** as shown in template and cut to length. Insert in hole **2**.

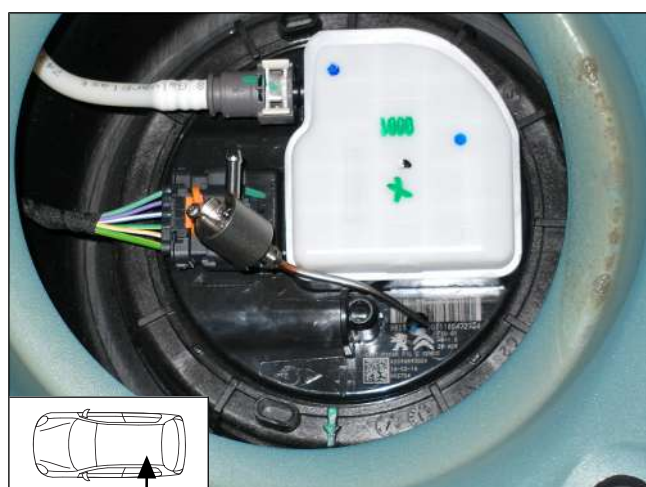

Fig. 37

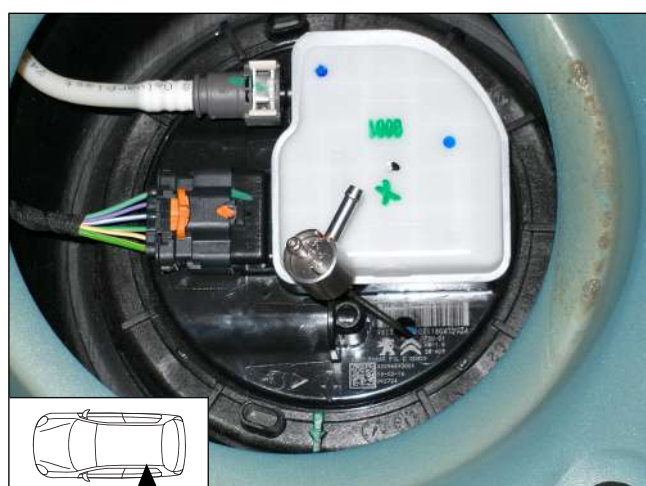

Fig. 38

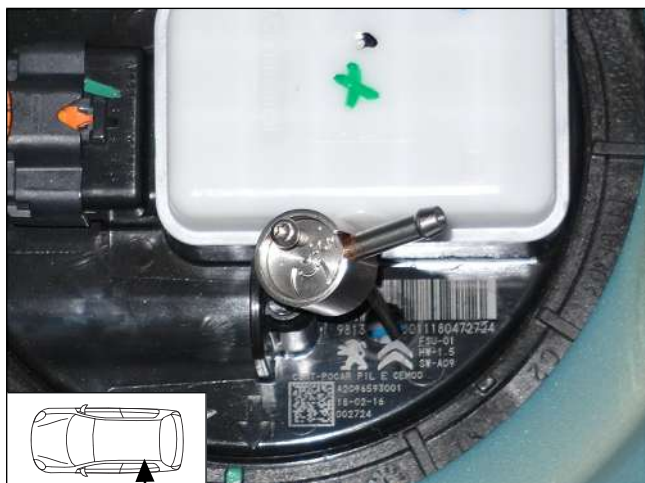

Fig. 39

Aligning FuelFix

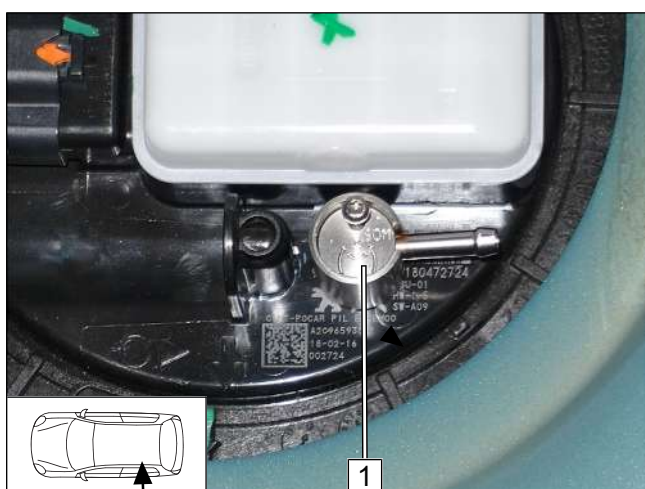

Fig. 40

- ▶ Work steps F5.3, F5.4
- ▶ Align FuelFix **1** as shown.

Connecting fuel line

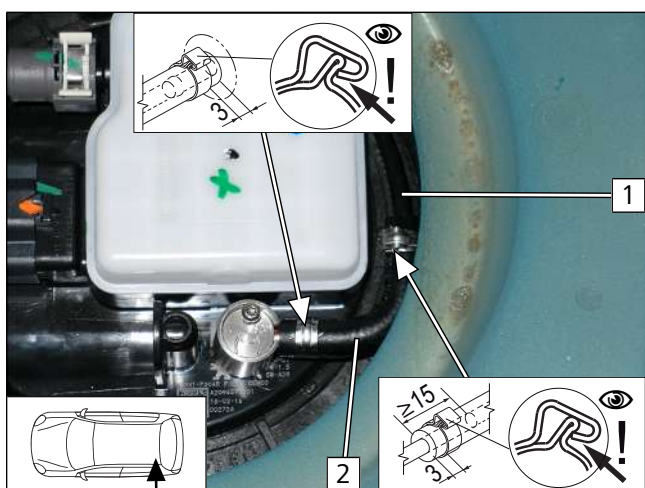

Fig. 41

- ▶ Work step F6
- 1** Fuel line
- 2** 90° moulded hose; 10mm dia. clamp [2x]



Mounting FuelFix

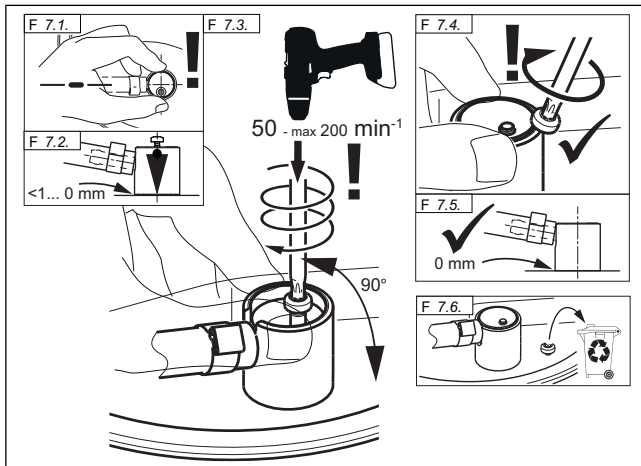

Fig. 42

Checking firm seating of FuelFix



Fig. 43

Securing fuel line

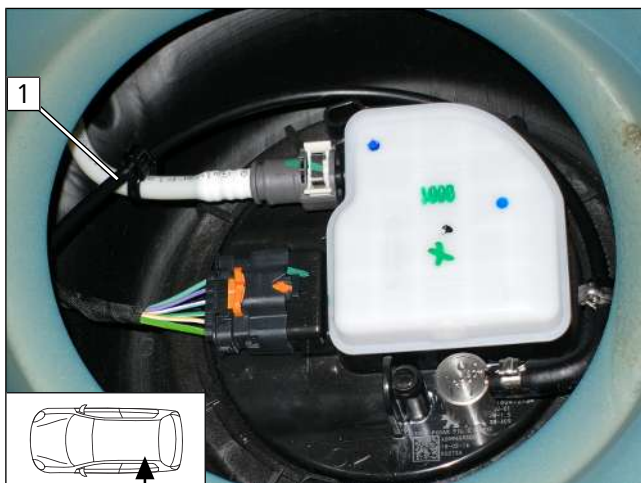

Fig. 44



DANGER

Risk of fire and explosion due to leaking fuel and escaping fuel vapours

► Work step F7

► Work step F8

► Secure fuel line **1** using a cable tie for tension relief.



9.3 Fuel pump connection

Connecting fuel line of FuelFix

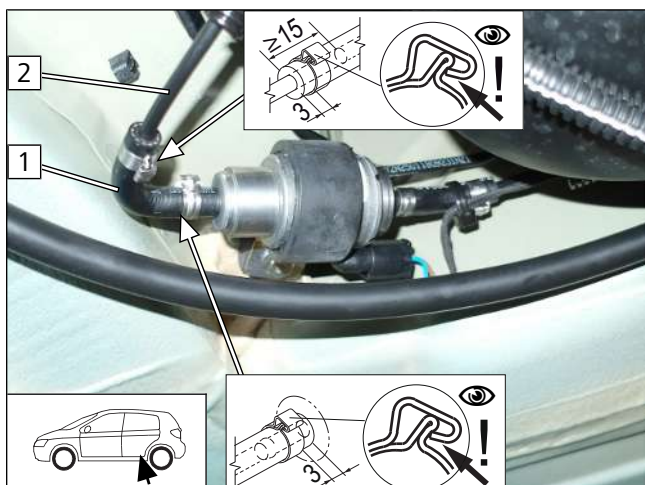

Fig. 45

- 1 90° moulded hose, 10mm dia. clamp [2x]
- 2 FuelFix fuel line in corrugated tube





10 Coolant

10.1 Hose routing diagram

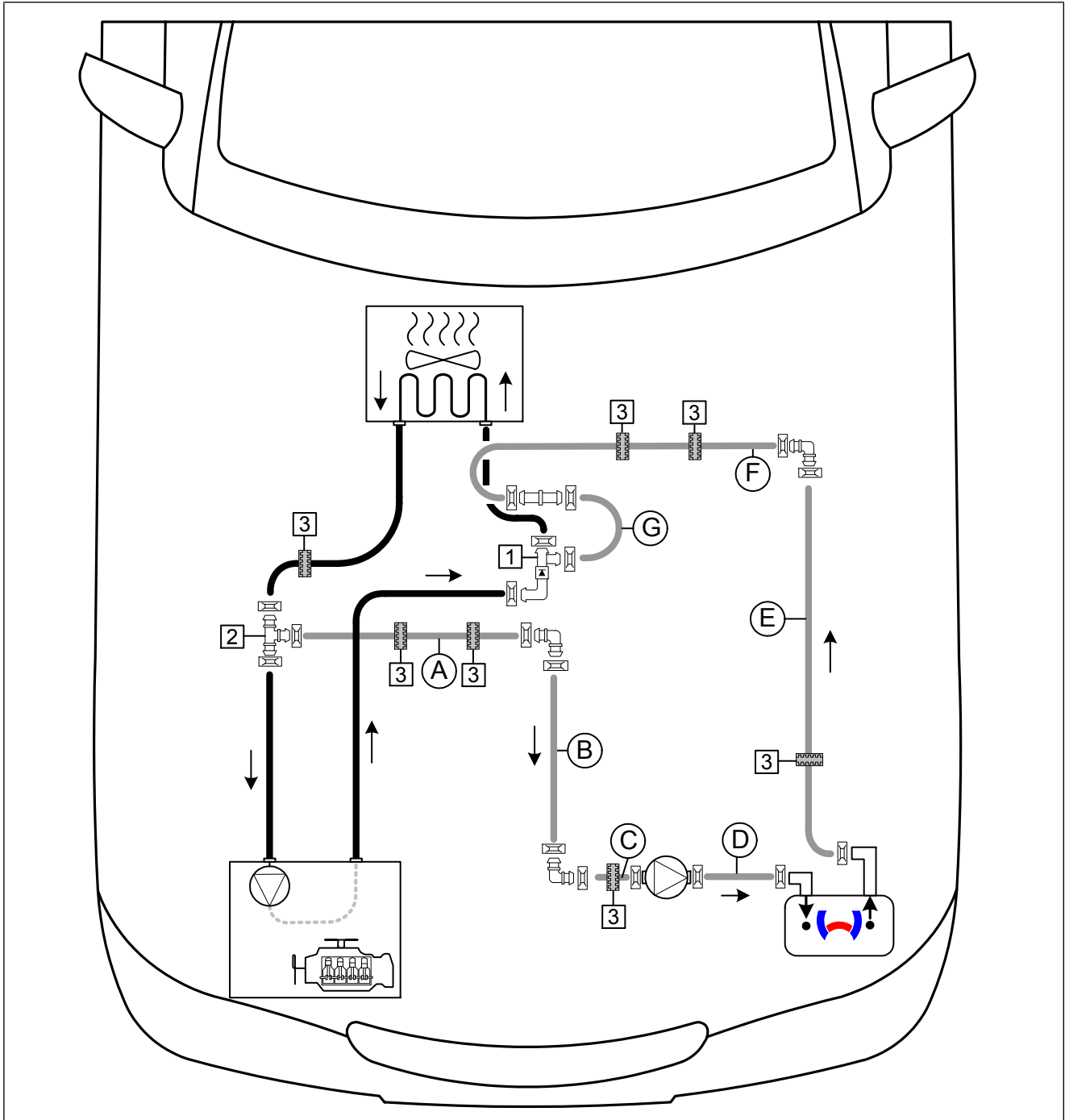
'Island' coolant circuit



▶ All spring clips  = 25mm dia.

▶ All connecting pipes  or  = 18x18mm dia.

1 Non return-valve 

2 T-piece 

3 Black rubber isolator 



10.2 Coolant circuit installation

Preparing hoses



Fig. 46

Premounting coolant pump

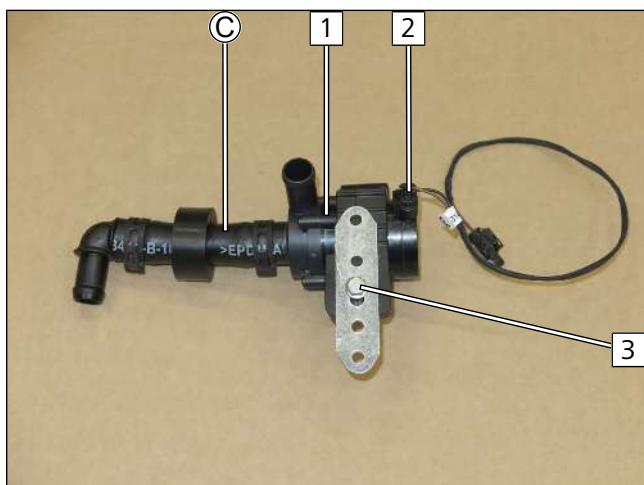

Fig. 47

- 1 Coolant pump
- 2 Coolant pump wiring harness connector
- 3 M6x25 bolt, perforated bracket, coolant pump mount, flanged nut

Mounting coolant pump

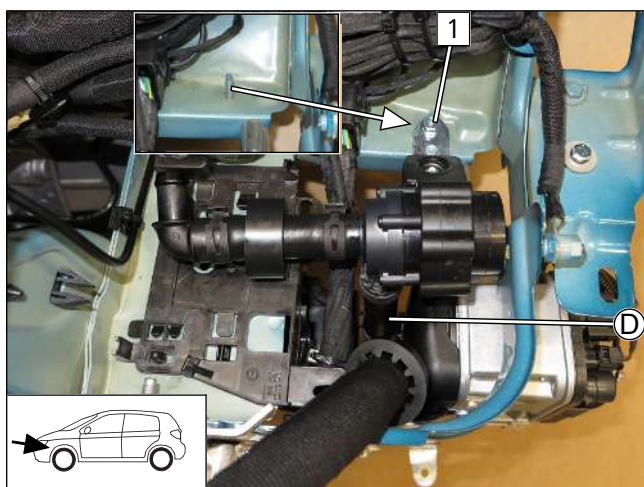

Fig. 48

► Mount hose **D** on the coolant pump.

- 1 Original vehicle stud bolt, perforated bracket, flanged nut M6



Mounting coolant pump wiring harness

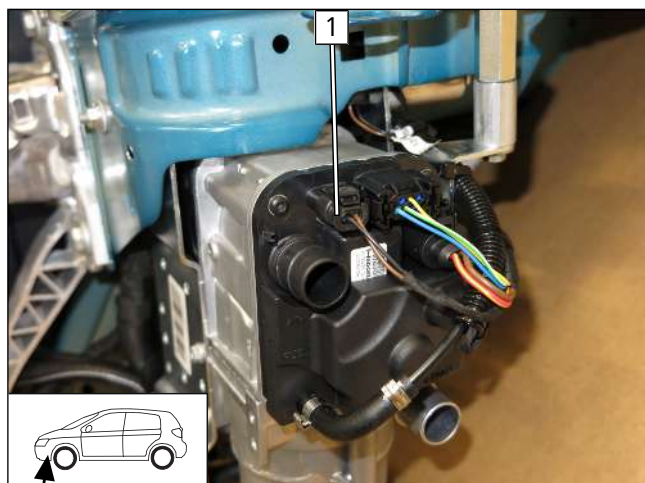

Fig. 49

- 1 Coolant pump wiring harness connector

Dismantling hoses

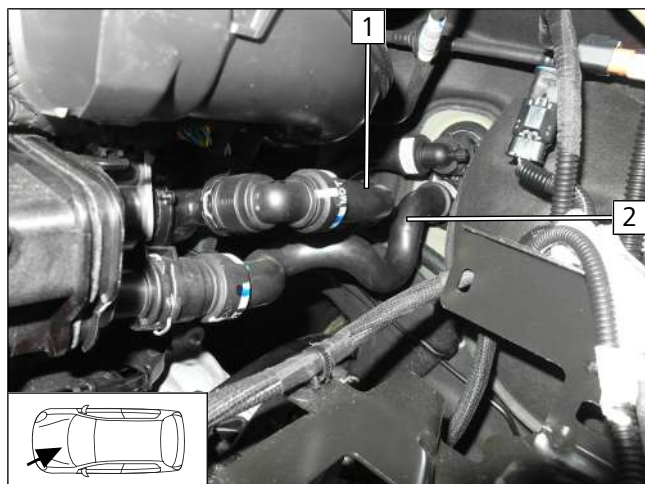

Fig. 50

- Remove hose of heat exchanger outlet **1** and heat exchanger inlet **2**.

Cutting point 1

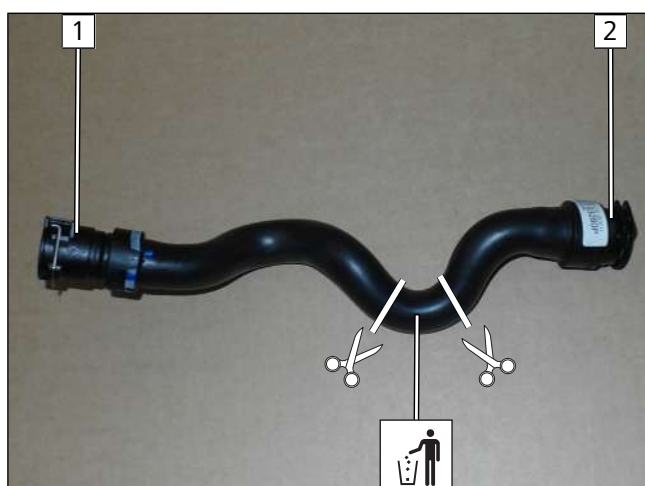

Fig. 51

- 1 Engine outlet connection
- 2 Heat exchanger inlet connection



Premounting non-return valve

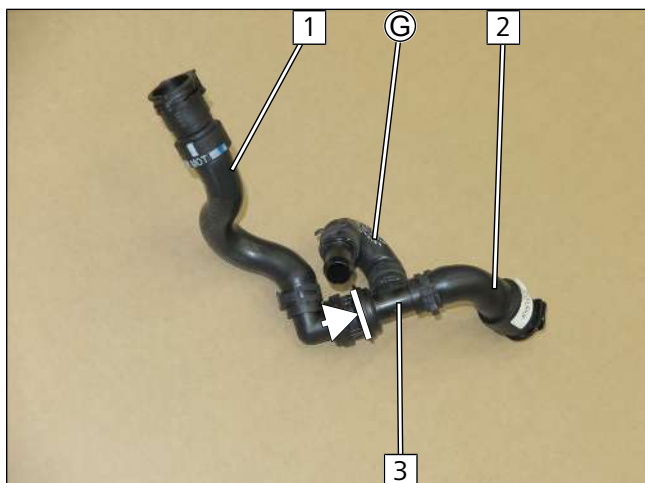

Fig. 52

- 1 Engine outlet hose section
- 2 Heat exchanger inlet hose section
- 3 Non-return valve

Cutting point 2

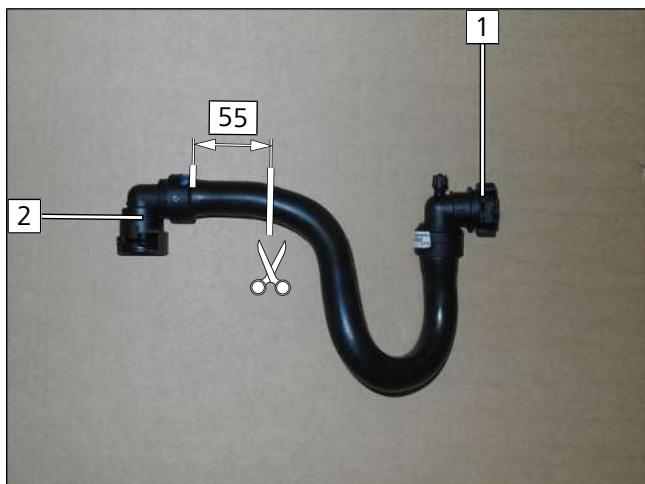

Fig. 53

- 1 Heat exchanger outlet connection
- 2 Engine inlet connection

Premounting T-piece

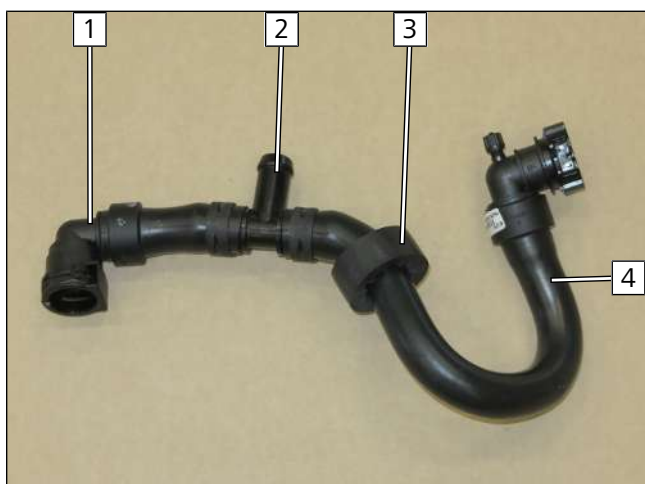

Fig. 54

- 1 Engine inlet hose section
- 2 T piece
- 3 Black rubber isolator
- 4 Heat exchanger outlet hose section



Mounting heat exchanger inlet hose

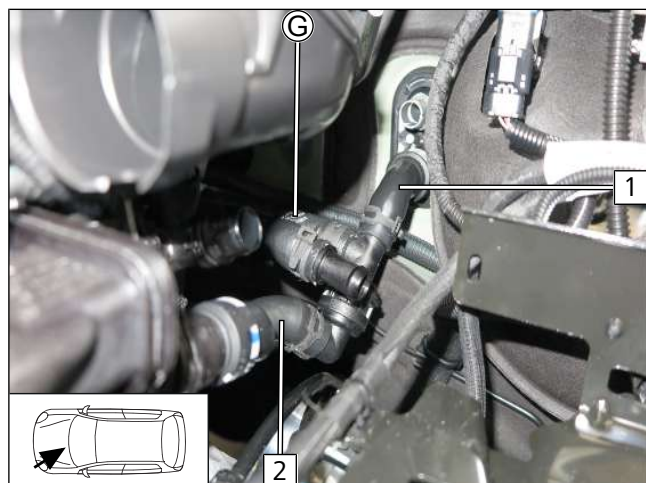

Fig. 55

- 1 Heat exchanger inlet hose section
- 2 Engine outlet hose section

Mounting edge protection

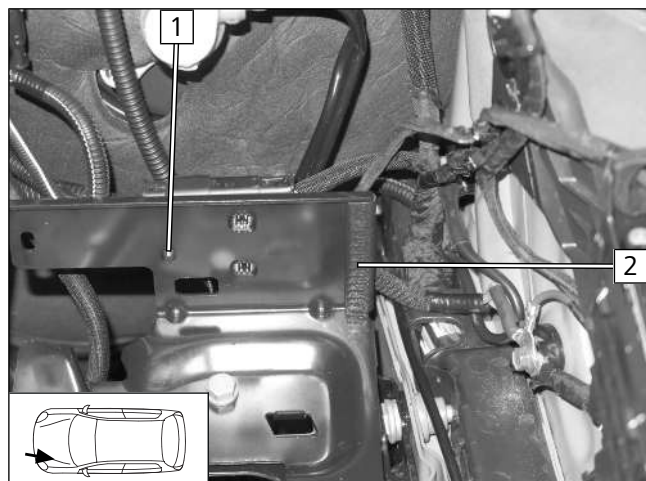

Fig. 56

► Detach original vehicle connector with clip **1**, will be fastened later with cable ties.

- 2 Edge protection

Routing hoses

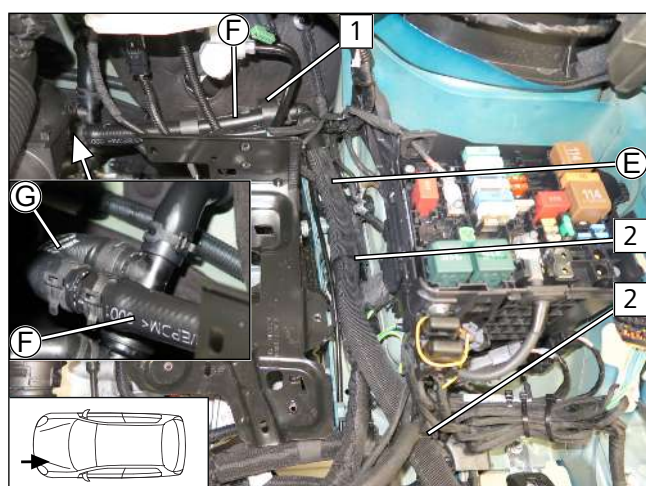

Fig. 57

- 1 Align rubber isolator with brake line
- 2 Cable tie



Fastening original vehicle wiring harness

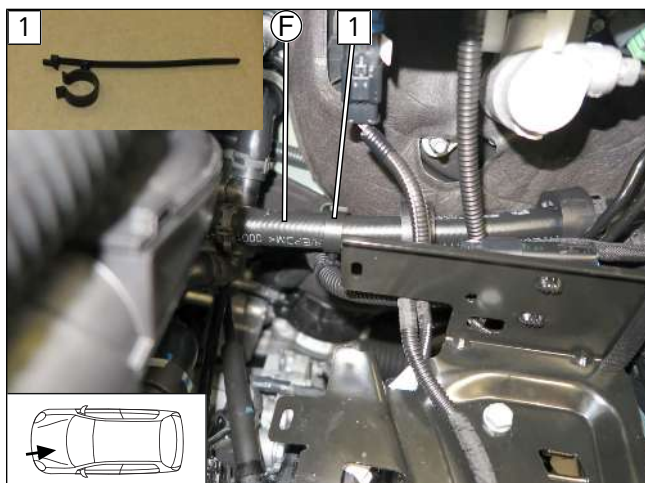

Fig. 58

- Fasten original vehicle wiring harness with hose bracket **1**.

Mounting heat exchanger outlet hose



Fig. 59

- 1** Align rubber isolator with hose **G**
- 2** Premounted hose of engine inlet / heat exchanger outlet

Mounting hose **B** onto hose **C**

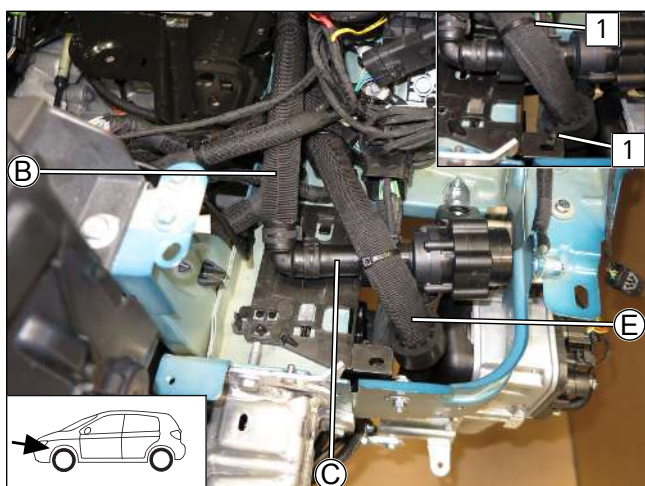

Fig. 60

- 1** Cable tie around hose **E** and rubber isolator



Mounting hose **A** and hose **B**

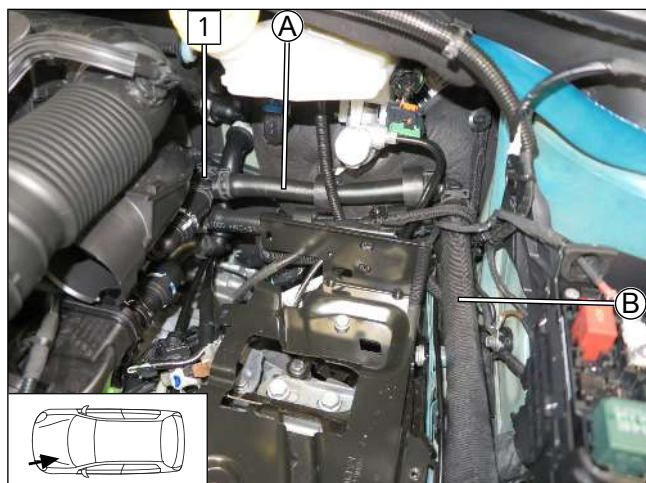

Fig. 61

1 T piece

Fastening hoses

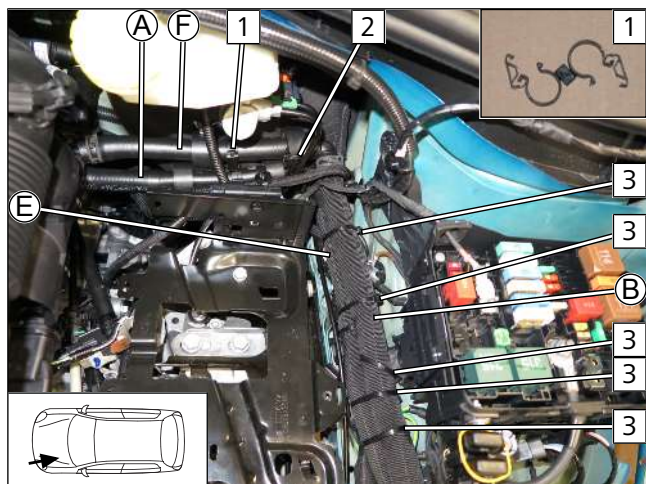

Fig. 62

► Align rubber rubber isolators.

- 1** Lockable hose bracket between hose **A** and hose **F**
- 2** Cable tie between rubber isolator and brake line
- 3** Cable tie

Checking distance

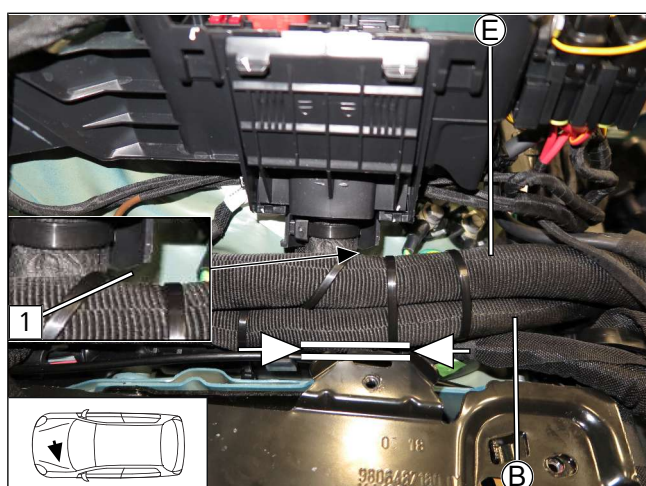

Fig. 63



Ensure sufficient distance between hose and bracket, correct if necessary.



► Remove plastic corner **1** of relay box.



Fastening connector

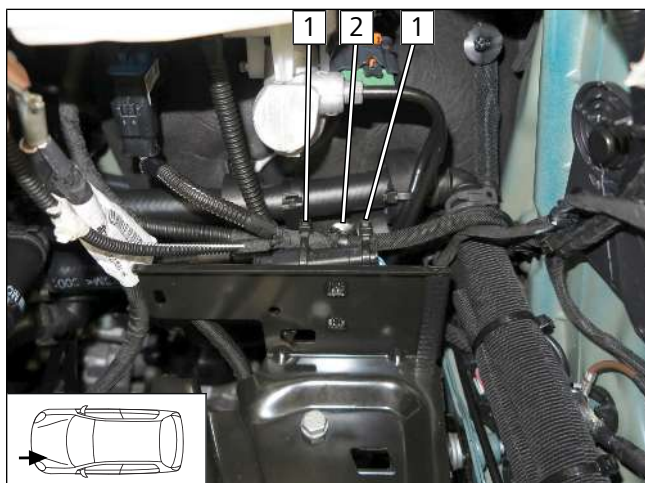

Fig. 64

- Fasten original vehicle connector using clip **2** and cable tie **1**.



11 Combustion air

Preparing angle bracket

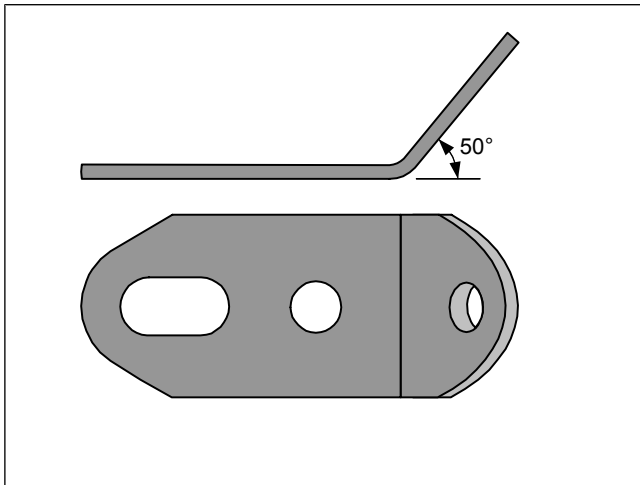

Fig. 65

Mounting angle bracket

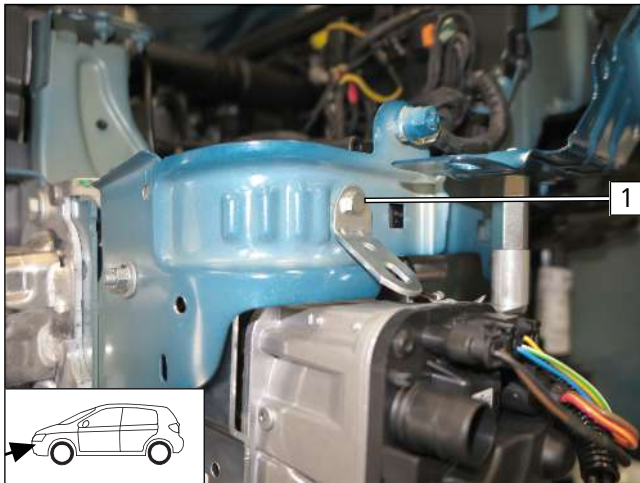

Fig. 66

- 1 M6x20 bolt, angle bracket, original vehicle hole, flanged nut

► Mount headlight.

Mounting combustion air intake silencer

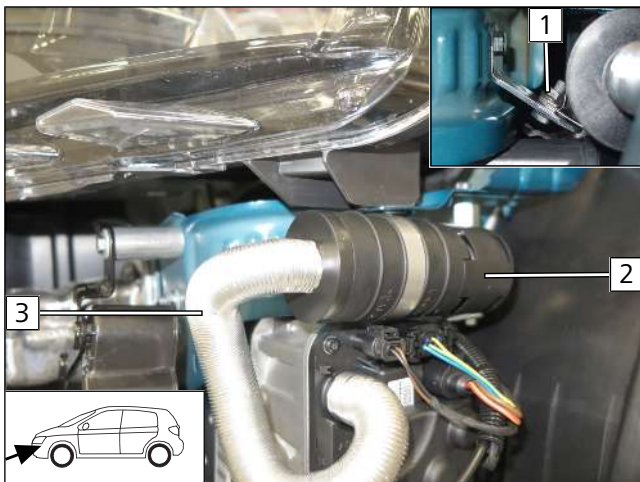
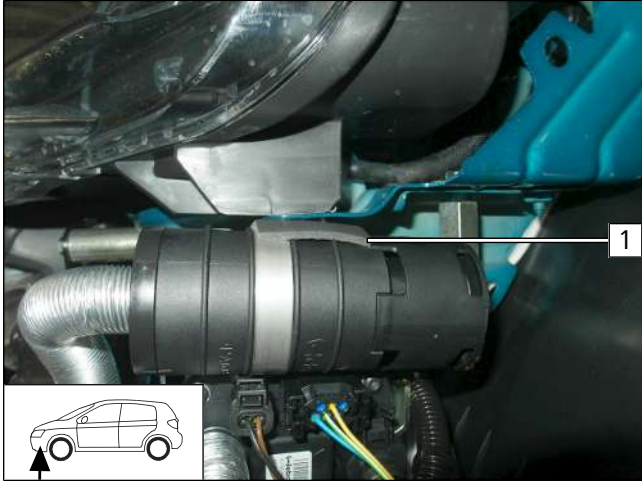

Fig. 67

- 1 M5x16 bolt, large diameter washer, angle bracket, 51mm dia. p-clamp, flanged nut
- 2 Combustion air intake silencer
- 3 Combustion air pipe



Gluing foam



► Glue foam **1** as rub protection.

Fig. 68



12 Exhaust

Cutting exhaust pipe to length

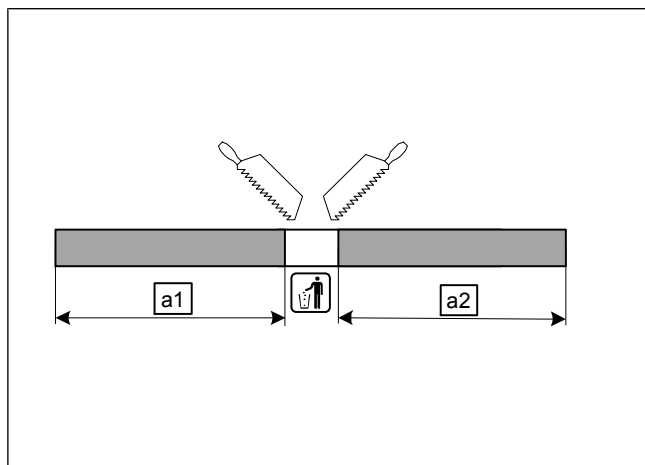

a1 200

a2 270

Fig. 69

Preparing exhaust pipe

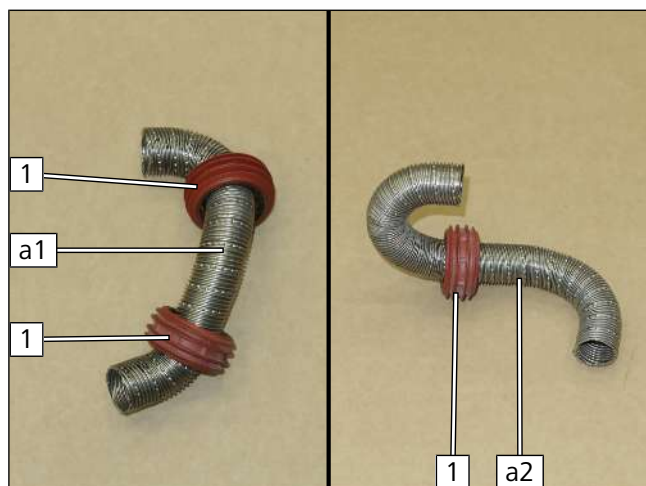

► Bend exhaust pipes **a1** and **a2** as shown.

1 Spacer bracket

Fig. 70

Mounting exhaust silencer

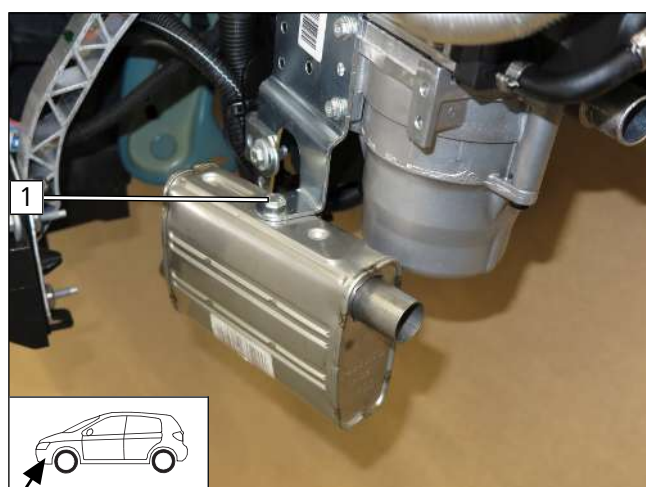

1 M6x16 bolt, spring lockwasher, bracket, exhaust silencer

Fig. 71



Mounting exhaust pipe **a1**

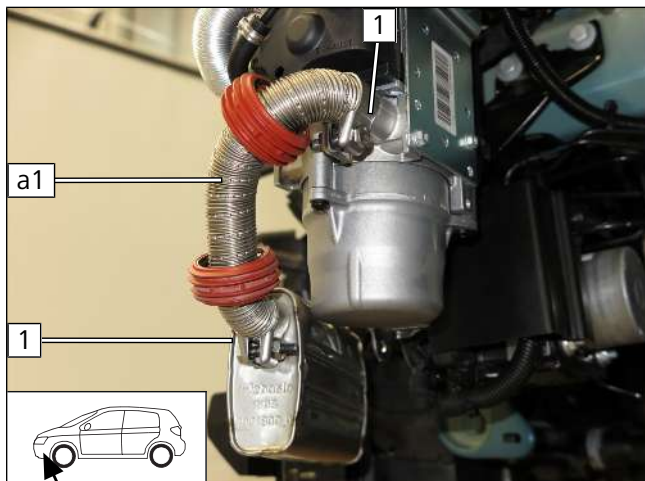

Fig. 72

- 1** Hose clamp

Mounting exhaust pipe **a2**

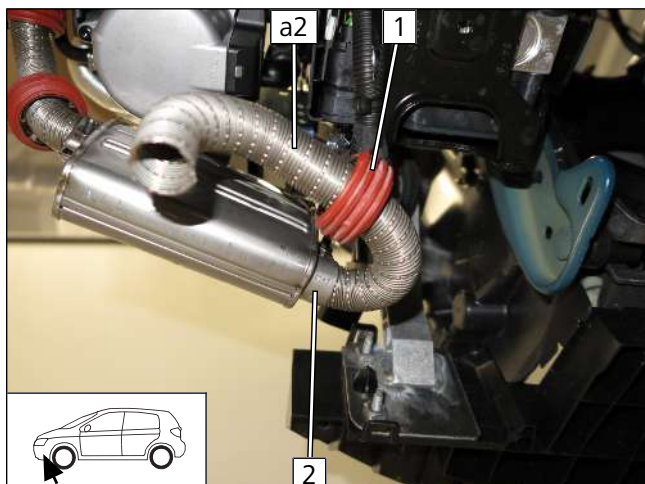

Fig. 73

- 1** Spacer bracket
- 2** Hose clamp

Copying hole pattern, drilling hole

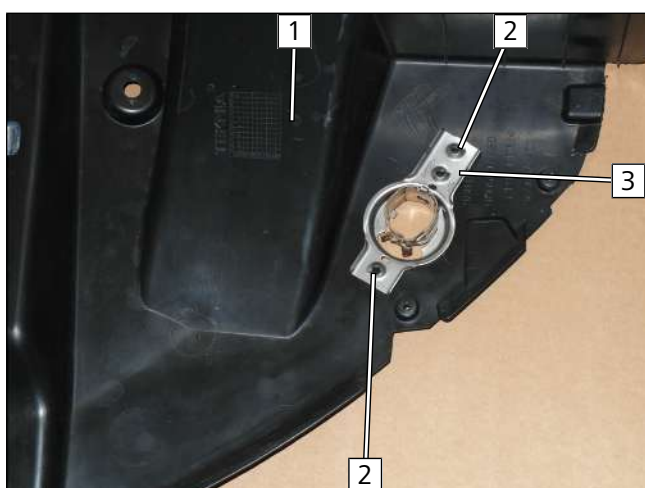

Fig. 74



Observe the EFIX installation instructions.

- Work steps E1 to E3
- Align EFIX **3** with existing hole in wheel well **1** as shown.
 - 2** Hole pattern

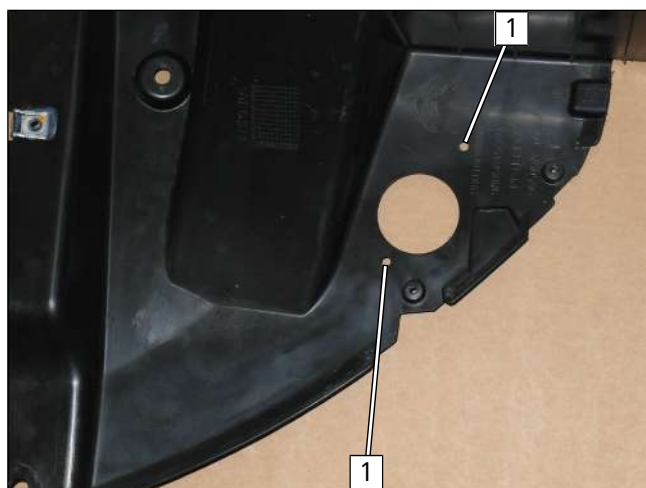

Fig. 75

► Work step E4

1 Hole

Mounting EFIX

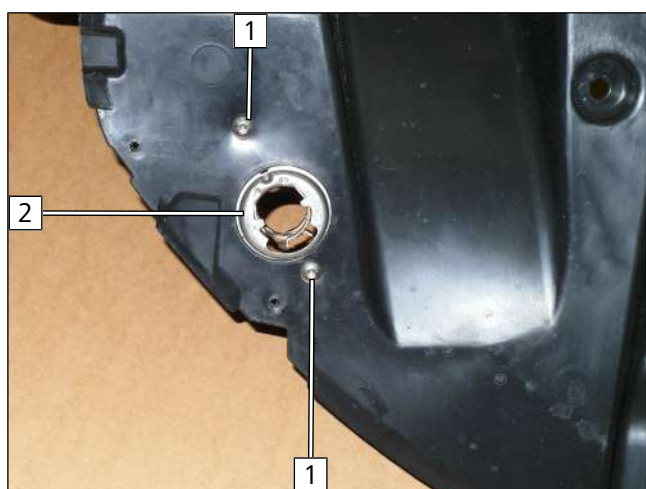

Fig. 76

► Work step E5

1 5x13 self-tapping screw

2 EFIX

13 Final work in engine compartment

Drilling hole

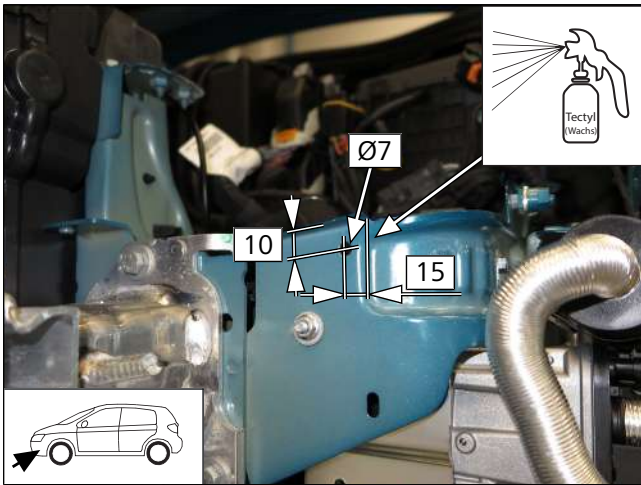

Fig. 77

Mounting control unit

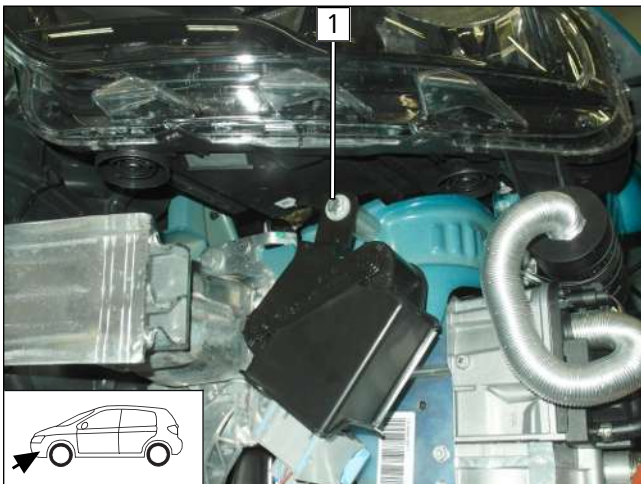

Fig. 78

- 1 M6x55 bolt, large diameter washer, control unit bracket, 40mm spacer, drilled hole, flanged nut

Loosening original vehicle wiring harness



Fig. 79

- Detach original vehicle wiring harness at pos. 1 and 2.

Drilling hole

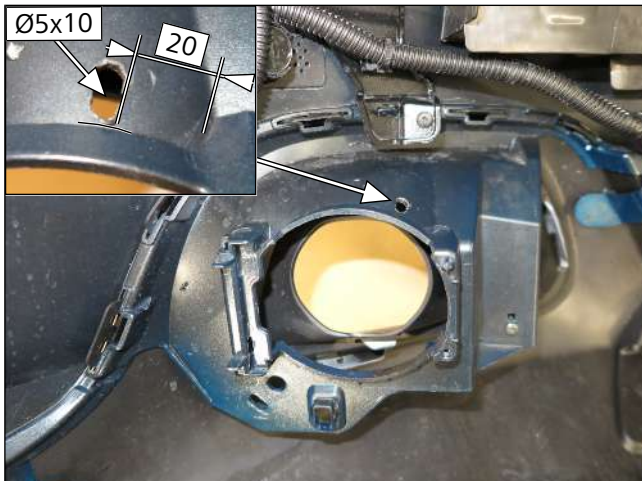

Fig. 80

Mounting original vehicle wiring harness



Fig. 81

- 1 Fasten connector using drilled hole
- 2 Fasten original vehicle wiring harness with edge clip cable tie

Aligning spacer bracket

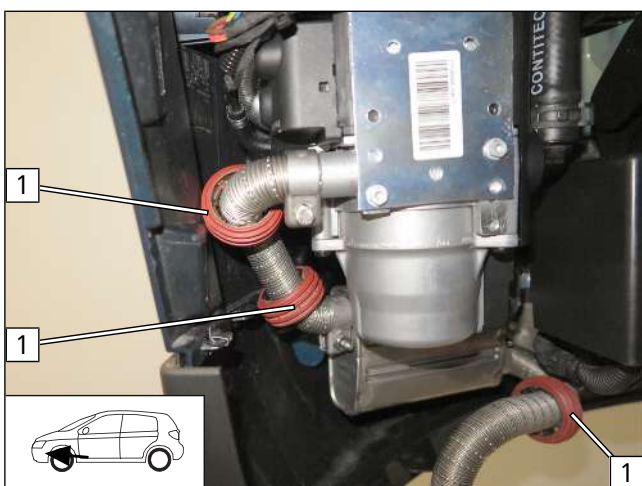

Fig. 82

- 1 Spacer bracket

Checking distance

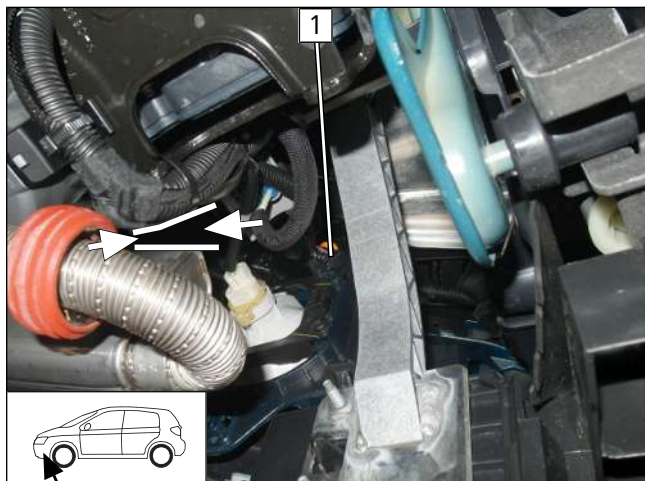

Fig. 83



Danger of damage to components

- ▶ Ensure sufficient distance between original vehicle wiring harness and exhaust system, secure wiring harness with cable ties if necessary.

1 Mount connector of bumper

Mounting exhaust pipe **a2**

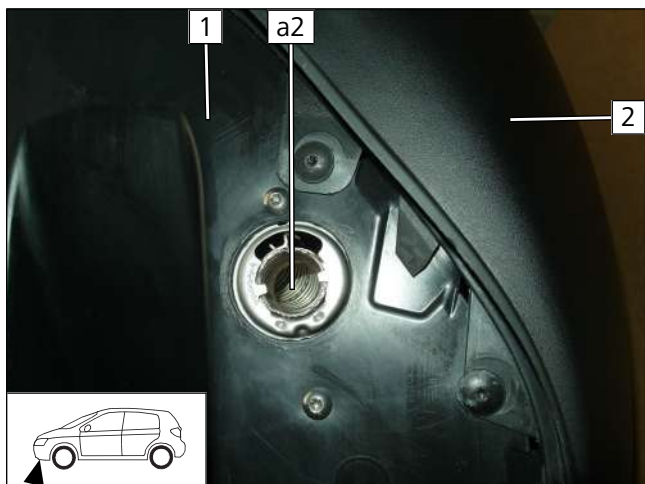

Fig. 84



Observe the EFIX installation instructions.

- ▶ Work steps E6 - E8
- ▶ Mount bumper **2** and wheel well trim **1**.



14 Electrical system of passenger compartment

14.1 Passenger compartment dismantling instructions

Dismantling lower instrument panel trim on driver's side

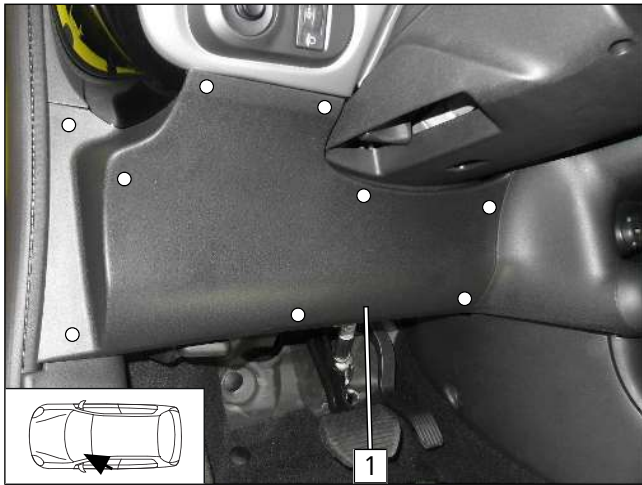

Fig. 85

► Detach lower instrument panel trim on the driver's side **1** by pulling it in the opposite direction of travel.

○ Fastening clip [9x]

Dismantling centre console side trim on driver's side

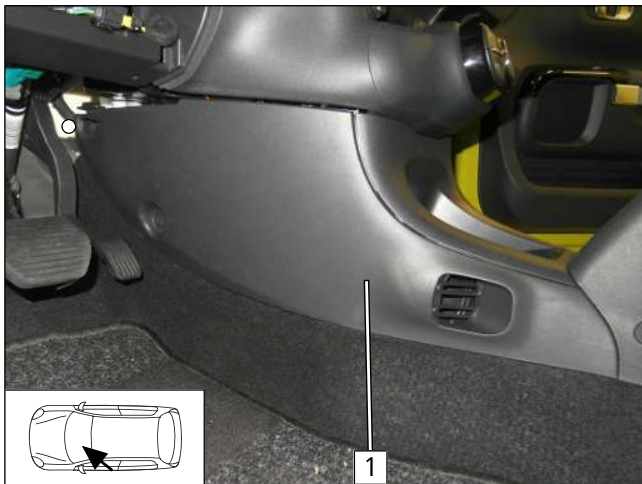

Fig. 86

1 Centre console side trim

Dismantling storage compartment under glove box

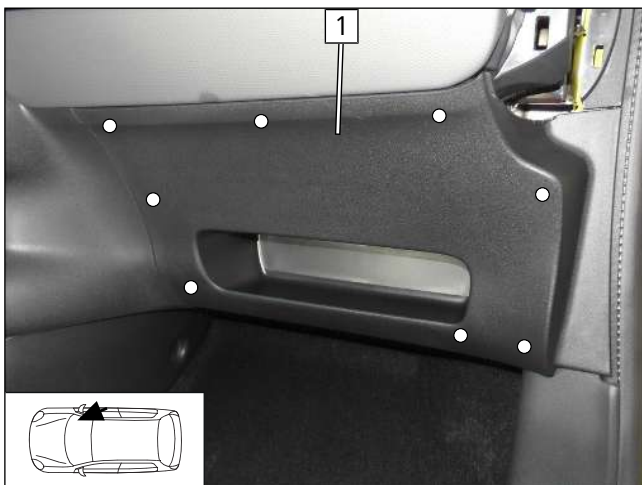

Fig. 87

► Detach storage compartment under glove box **1** by pulling it in the opposite direction of travel.

○ Fastening clip [8x]



Detaching OBD socket outlet

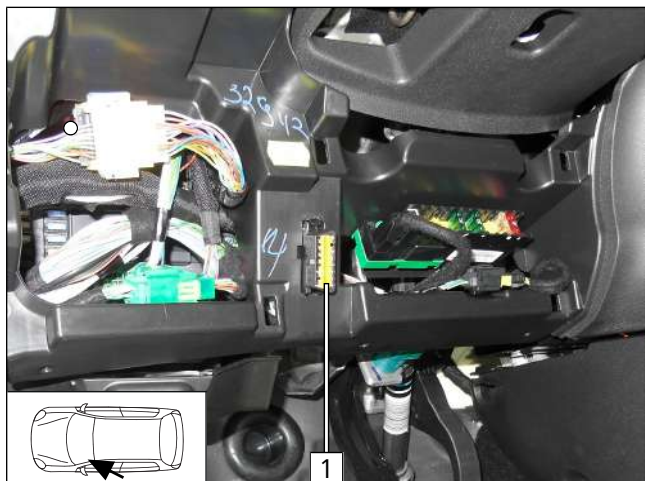

Fig. 88

- ▶ Detach OBD socket outlet **1** and reposition further down.



14.2 Electrical system preparation

Preparing and assigning wires

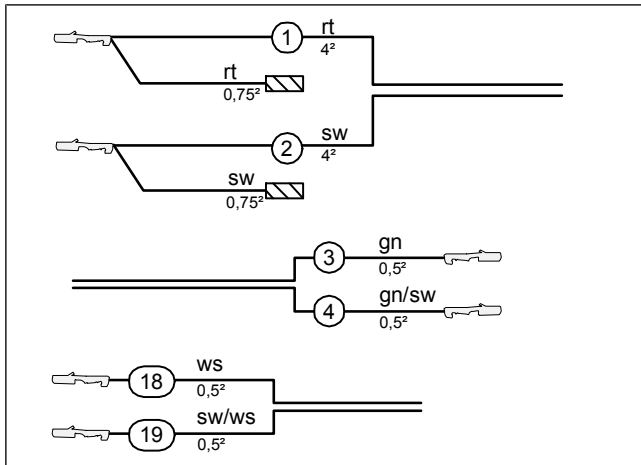

Fig. 89



Wire sections retain their numbering in the entire document.

- ① Red (rt) wire of fan wiring harness
- ② Black (sw) wire of fan wiring harness
- ③ Green (gn) wire from wiring harness of PWM control
- ④ Green/black (gn/sw) wire from wiring harness of PWM control
- ⑱ White (ws) wire of additional relay wiring harness
- ⑲ Black/white (sw/ws) wire of additional relay wiring harness

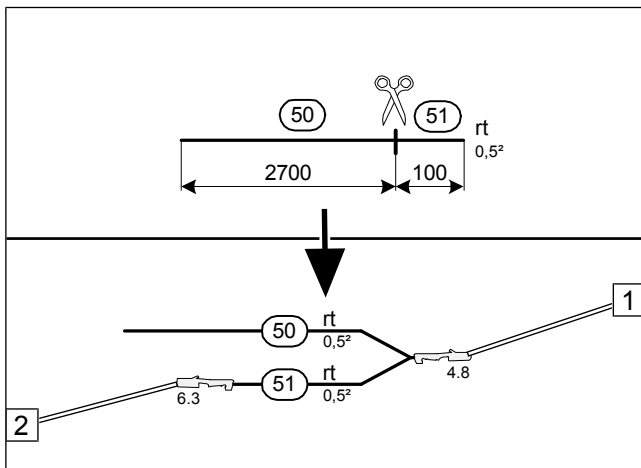

Fig. 90

- ① 4.8mm blade receptacle
- ② 6.3mm blade receptacle

View of PWM Gateway

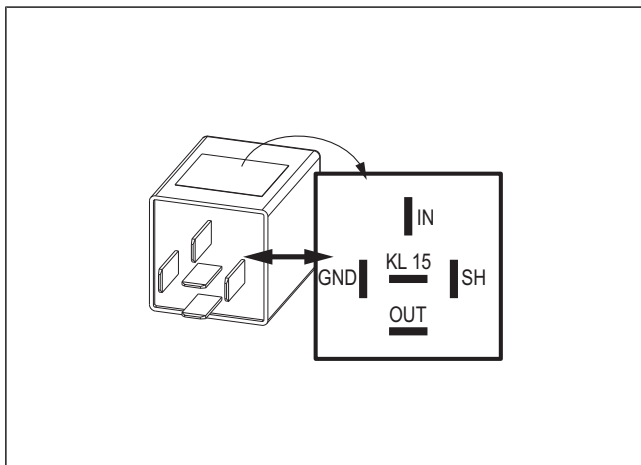

Fig. 91

► Check PWM Gateway settings when starting-up the heater, adjust if necessary.

Parameters	Setting
Duty cycle	70% [DC]
Frequency	400Hz
Voltage	not relevant
Function	Low side



Preparing relay K2 socket

- Uncrimp blue (bl) wire from K2 socket and insulate all blade receptacles as shown.

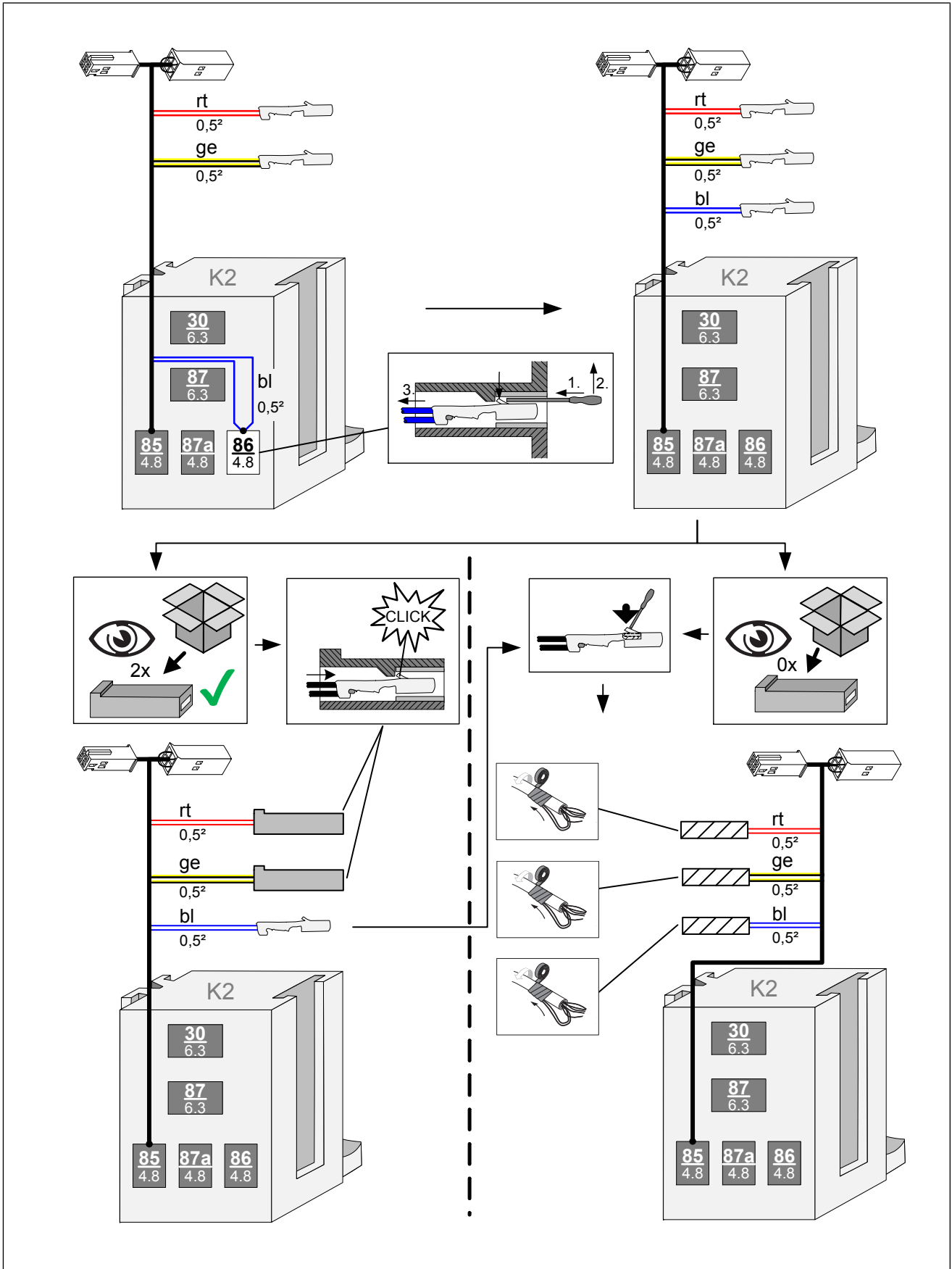

Fig. 92



Preparing RSH, PWM GW socket and K2

- ▶ Connect wires.
- ▶ Connect connectors and sockets.
- ▶ Assemble RSH, PWM GW socket and K2 socket.

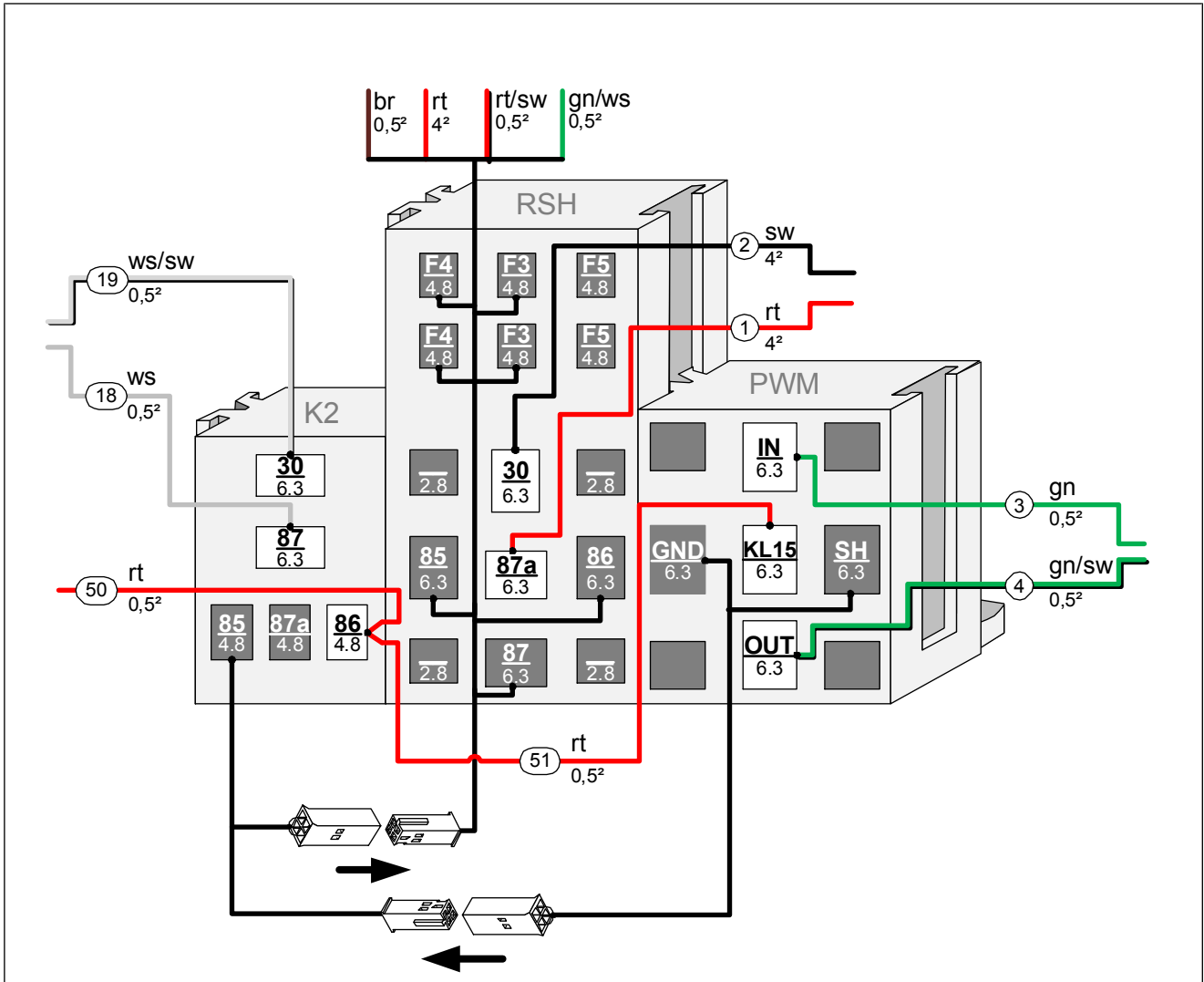

Fig. 93

Premounting relay and fuse holder

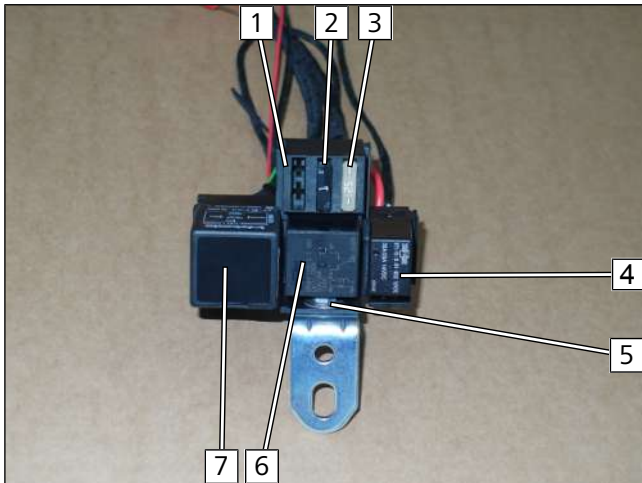

Fig. 94

- 1 RSH
- 2 Fuse F3: 1A
- 3 Fuse F4: 25A
- 4 Relay K2
- 5 M5x16 bolt, large diameter washer, RSH, angle bracket, large diameter washer, nut
- 6 Relay K1
- 7 PWM GW



14.3 Wiring diagram

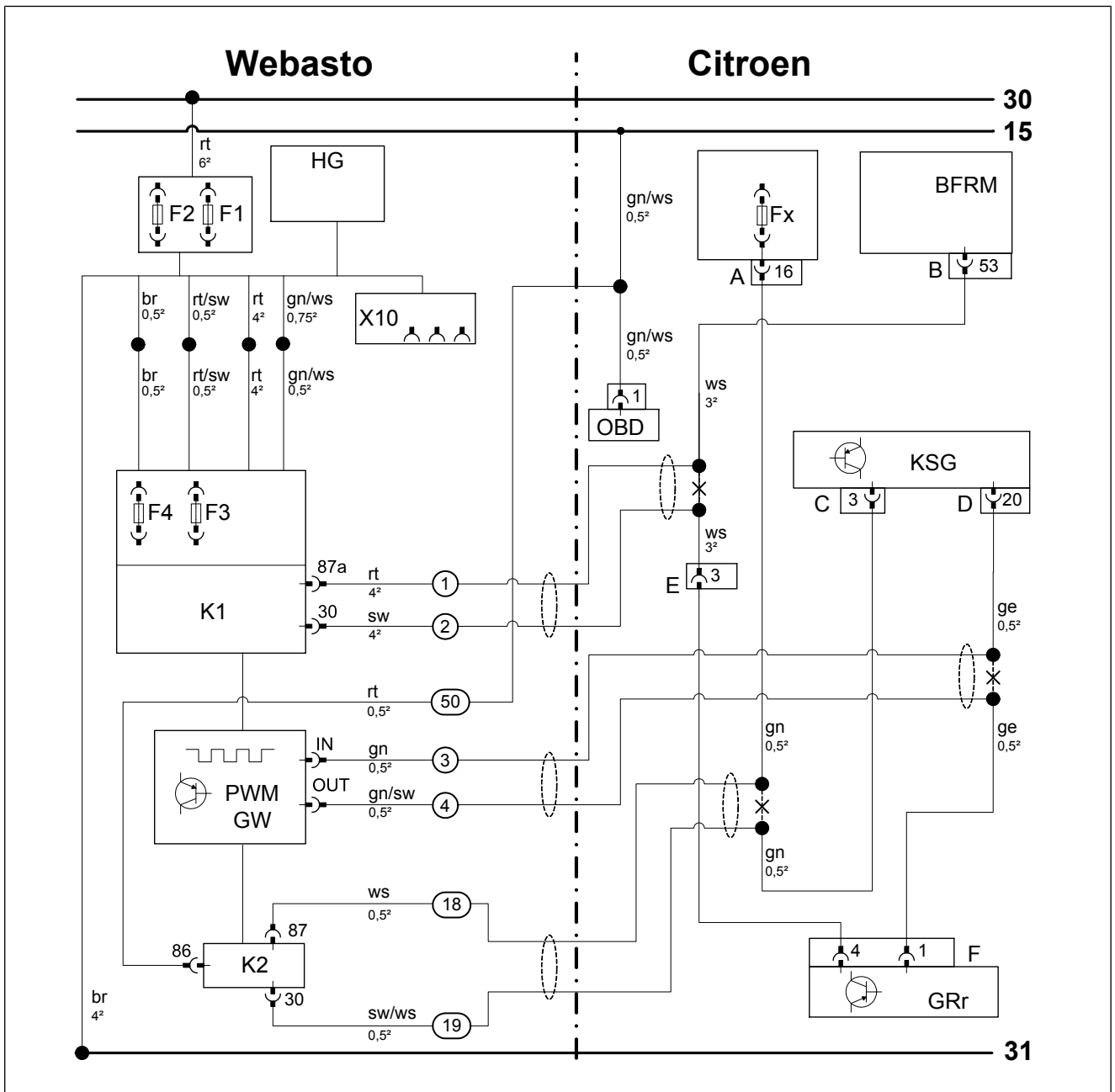

Fig. 95



Legend to wiring diagram

Vehicle components		Symbols	
Abbreviation	Component	Abbreviation	Explanation
Fx	Fuse	X	Cutting point
A	16-pin connector of central electrical box		
BGRM	Engine compartment fuse and relay carrier		
B	40-pin connector of engine compartment fuse and relay carrier		
KSG	Air-conditioning control unit		
C	6-pin connector of A/C control unit		
D	40-pin connector of A/C control unit		
E	2-pin connector		
GRr	Fan controller		
F	5-pin fan controller connector		

Webasto components		Cable colours	
Abbreviation	Component	Abbreviation	Colour
A	Connector of CLR module wiring harness	br	brown
B	Socket of CLR module wiring harness	bg	beige
CCL GW	CAN CAN LIN Gateway	dbl	dark blue
CL GW	CAN LIN Gateway	dgn	dark green
CLR	Cold start module	ge	yellow
D1	Diode	gn	green
D2	Diode group	gr	grey
F0	Additional fuse for power supply	hbl	light blue
F1	Heater main fuse	hgn	light green
F2	Passenger compartment fan controller main fuse	or	orange
F3	Heater control fuse	pk	pink
F4	Fan controller fuse	rt	red
F5	Additional fuse	sw	black
HG	Heater TT-Evo	vi	violet
K1	Relay K1	ws	white
K2	Relay K2		
K3	Relay K3		
LIN GW	LIN Gateway		
PWM GW	Pulse width modulator gateway		
RSH	Relay and fuse holder of passenger compartment		
RTD	Temperature sensor		
X10	4-pin socket of heater control		



14.4 Fan controller

Connecting same colour wires of wiring harnesses

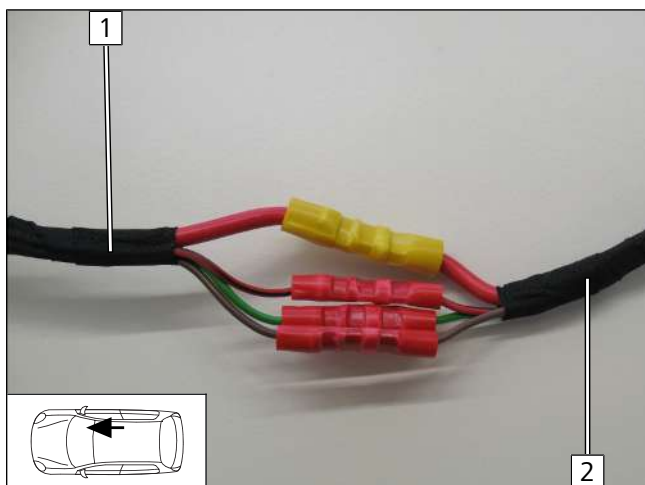

Fig. 96



Produce all following electrical connections as shown in the system wiring diagram.

- 1 Wiring harness of passenger compartment relay and fuse holder
- 2 Heater wiring harness

Mounting relay and fuse holder

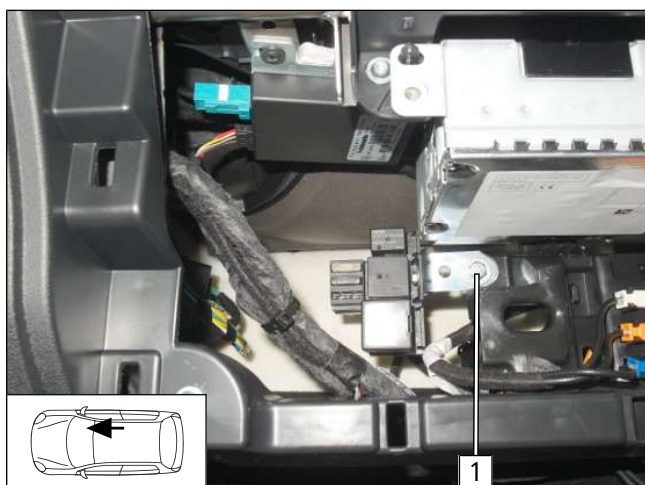

Fig. 97

- 1 M6x20 bolt, large diameter washer, flanged nut at existing hole

View of A/C control unit connector

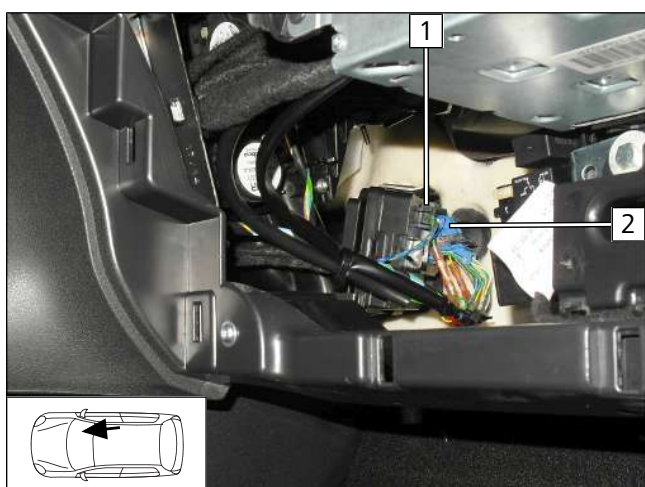

Fig. 98

- 1 Connector C of KSG
- 2 Connector D of KSG



Connection to relay K2

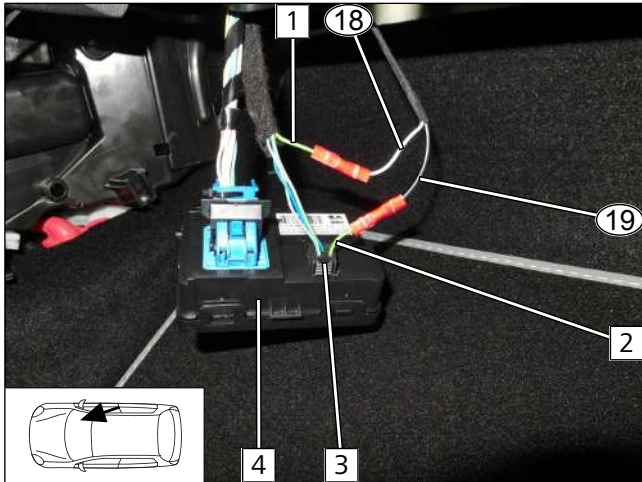

Fig. 99

- 1 Green (gn) wire of connector A
- 2 Green (gn) wire of connector C
- 3 Connector C of KSG
- 4 KSG
- 18 White (ws) wire of K2/87 from additional relay wiring harness
- 19 Black/white (sw/ws) wire of K2/30 from additional relay wiring harness

Air-conditioning control unit connector

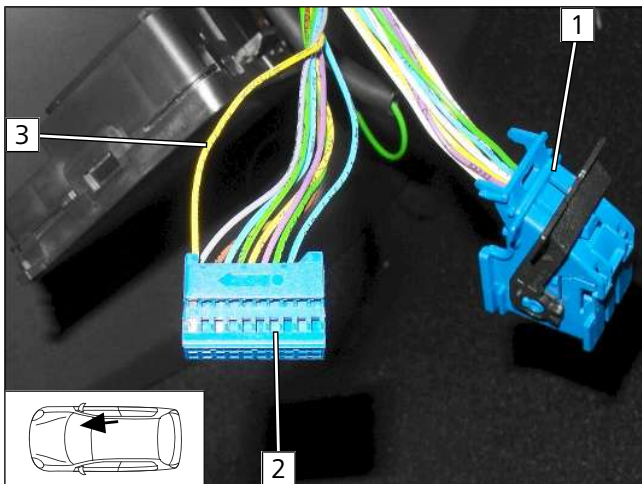

Fig. 100

► Disconnect connector D 1 from KSG and dismantle.

- 2 Blue contact strip of connector D, pin 1-20
- 3 Yellow (ge) wire, pin 20

PWM GW connection

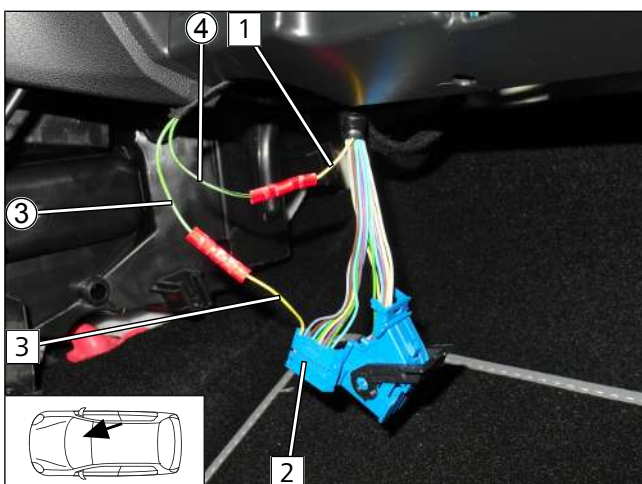

Fig. 101

- 1 Yellow (ge) wire of pin 1, connector F
- 2 Blue contact strip of connector D, pin 1-20
- 3 Green (gn) wire of PWM/IN wiring harness from PWM control
- 4 Green/black (gn/sw) wire of PWM/OUT wiring harness from PWM control



Relay K1 connection

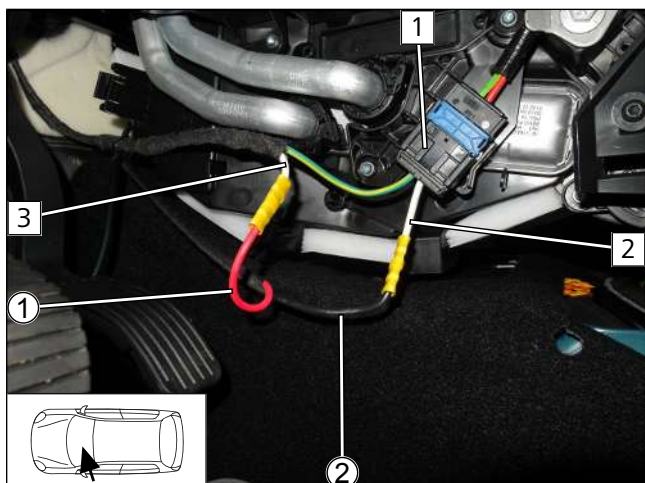

Fig. 102

- 1 2-pin connector E
- 2 White (ws) wire of pin 3, connector E
- 3 White (ws) wire of pin 53, connector B
- 1 Red (rt) wire of K1/87a fan wiring harness
- 2 Black (sw) wire of K1/30 fan wiring harness

Connection to OBD socket outlet

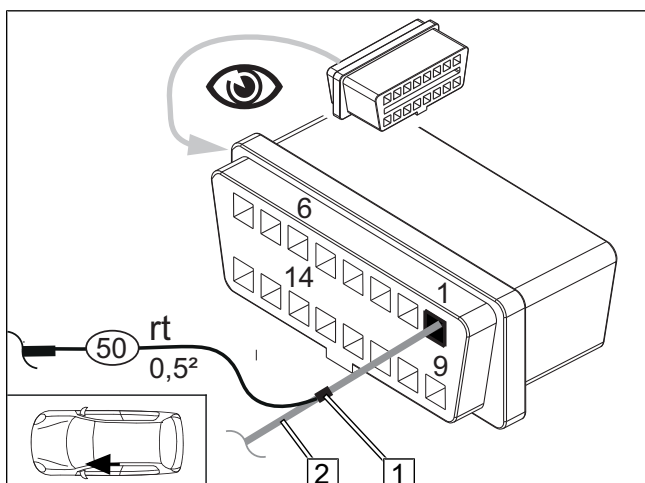

Fig. 103

► Remove OBD socket outlet from bracket.

- 1 Crimp butt connector
- 2 Green/white (gn/ws) wire of OBD/pin 1
- 50 Red (rt) wire of relay K2/86



15 Electrical system of control elements

15.1 Telestart option

Mounting receiver

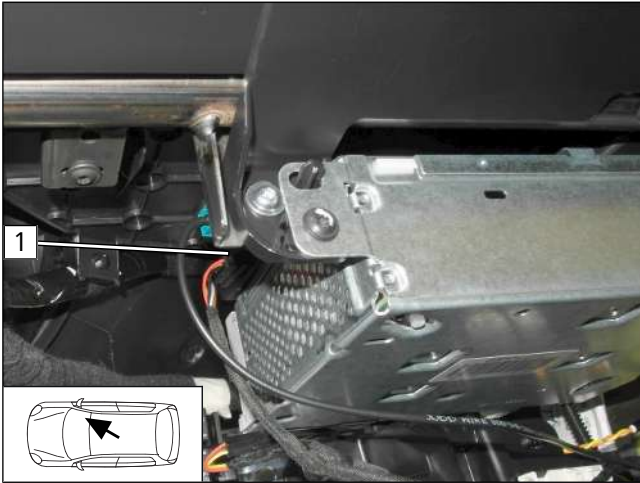

Fig. 104



Observe the Telestart installation documentation.

- Fasten receiver **1** (covered) on the radio and navigation system from above using double-sided adhesive tape.

Mounting aerial

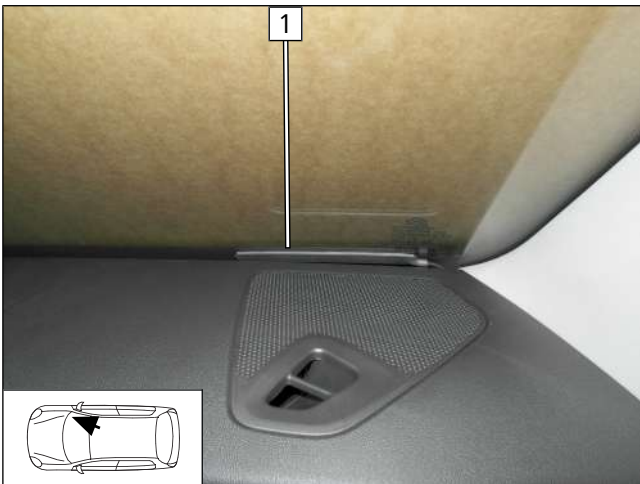

Fig. 105

1 Aerial

Mounting temperature sensor, only in case of T100 HTM

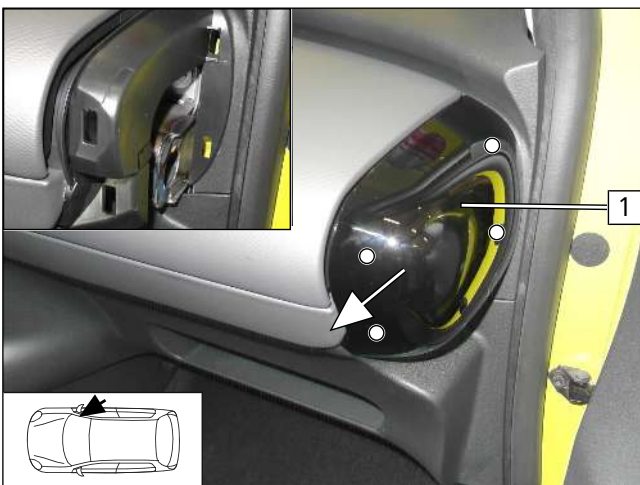

Fig. 106

- Detach right instrument panel trim **1** by pulling it in the opposite direction of travel.

○ Fastening clip [4x]

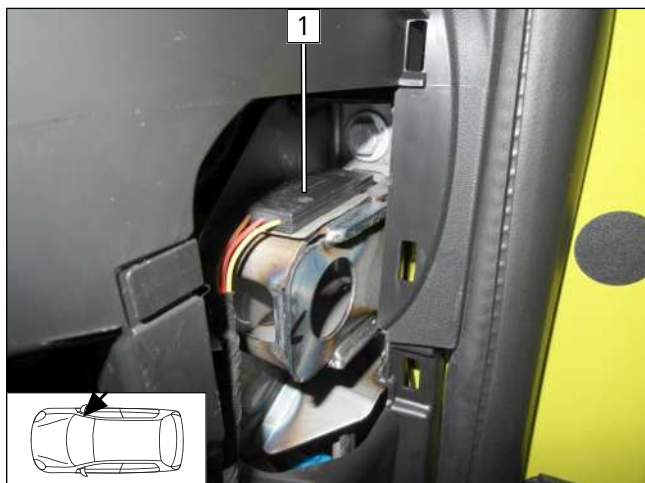

Fig. 107

- Fasten temperature sensor **1** using double-sided adhesive tape.

15.2 ThermoCall option

Mounting receiver

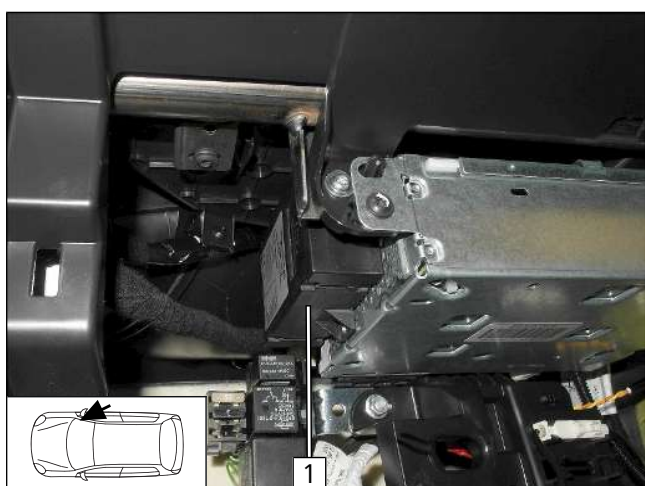

Fig. 108



Observe the ThermoCall installation documentation.

- Fasten receiver **1** using double-sided adhesive tape.

Mounting aerial (optional)

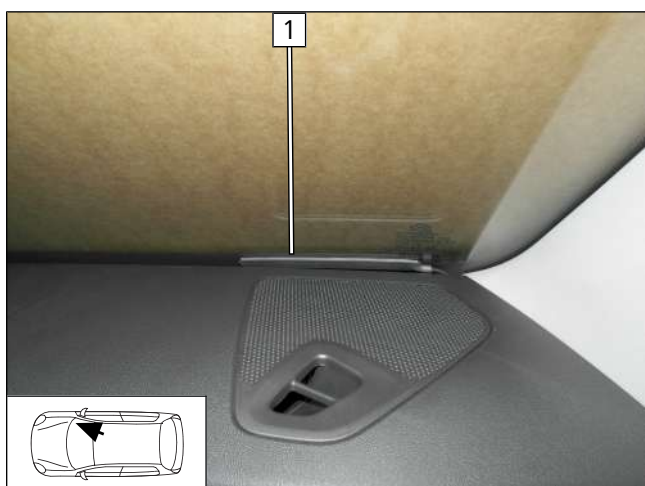

Fig. 109

1 Aerial



16 Final Work



Further information can be found in the vehicle manufacturer's technical documentation.

- ▶ Mount removed parts in reverse order.



- ▶ Check all hoses, clamps and all electrical connections for firm seating.
- ▶ Insulate and tie back loose lines
- ▶ Spray heater and electrical components with anti-corrosion wax (Tectyl 100K).
- ▶ Connect the battery.



Only use manufacturer-approved coolant.

- ▶ Fill and bleed the coolant circuit according to the vehicle manufacturer's specifications.



Further information can be found in the general installation and operating instructions of the Webasto components.

- ▶ Program MultiControl CAR, teach Telestart transmitter
- ▶ Make settings on A/C control panel according to the 'Operating Instructions'.
- ▶ Initial operation and functional test
- ▶ Affix 'Switch off parking heater before refueling' caution label in area of filler neck

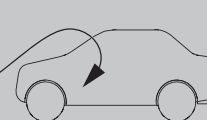
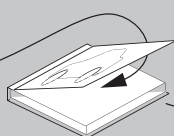
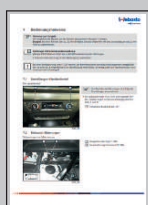
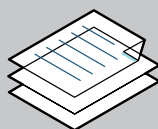

These are the original instructions. The German language is binding.
You can request your language if it is missing. The telephone number of each country can be found in the Webasto service centre leaflet or the website of the respective Webasto representative of your country.

Ident No. 1326789A_EN • 11/18 • Errors and omissions excepted • © Webasto Thermo & Comfort SE • 2018

Company address:
Friedrichshafener Str. 9
82205 Gilching
Germany





17 Bracket A template

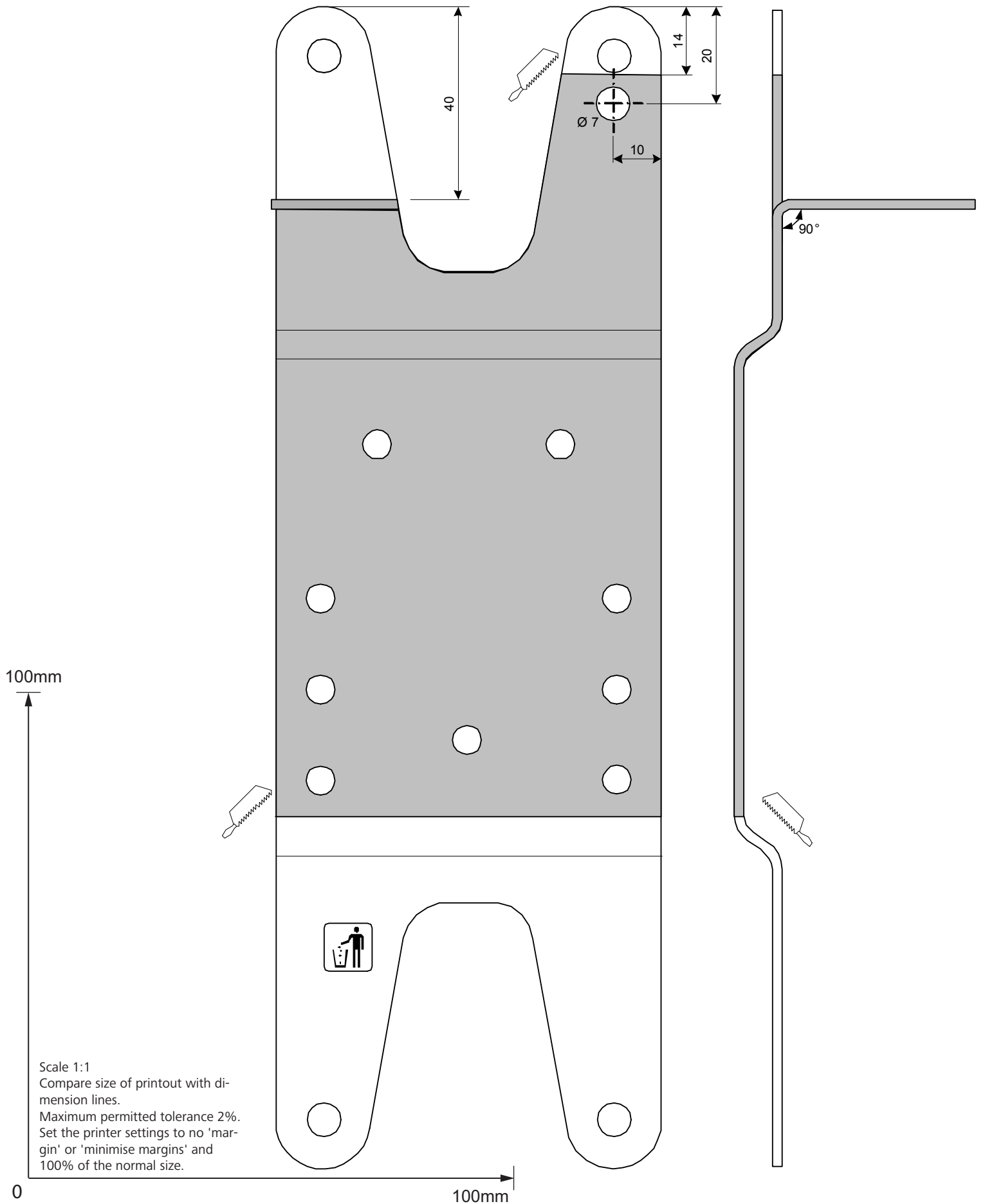

Scale 1:1
Compare size of printout with dimension lines.
Maximum permitted tolerance 2%.
Set the printer settings to no 'margin' or 'minimise margins' and 100% of the normal size.



18 Bracket B template

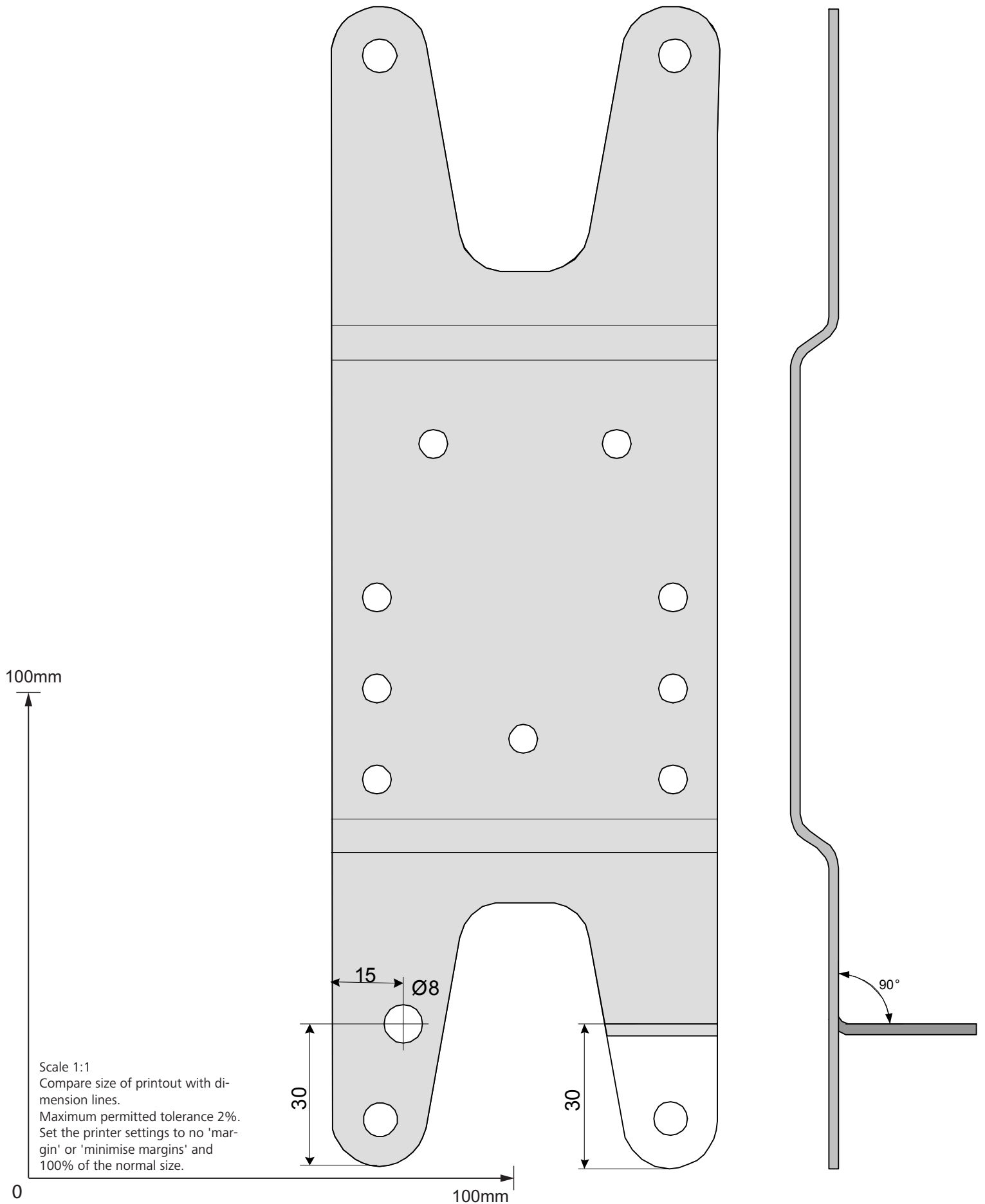

Scale 1:1
Compare size of printout with dimension lines.
Maximum permitted tolerance 2%.
Set the printer settings to no 'margin' or 'minimise margins' and 100% of the normal size.



19 FuelFix template



100mm

0

100mm

Scale 1:1
Compare size of printout with dimension lines.
Maximum permitted tolerance 2%.
Set the printer settings to no 'margin' or 'minimise margins' and 100% of the normal size.

20 Operating instructions



Vehicles with passenger compartment monitoring:

Further information can be found in the vehicle operating instructions.

- ▶ Deactivate passenger compartment monitoring for the heating operation



Information regarding the heating time:

We recommend matching the heating time to the driving time (heating time = driving time)

Example: for a driving time of approx. 20 min. (in one direction), we recommend not exceeding a switch-on time of 20 min.



Note for parking heater function

Your vehicle is equipped with a passenger compartment preheating unit. There is **no** engine pre-heating.

20.1 A/C control panel settings

Automatic A/C control panel



Fig. 110



Before parking the vehicle, make the following settings:

- ▶ The fan speed must not be preset.

- 1 Air outlet directed 'upwards'
- 2 Set temperature to 'Hi'

20.2 Installation location of fuses

Fuses in engine compartment

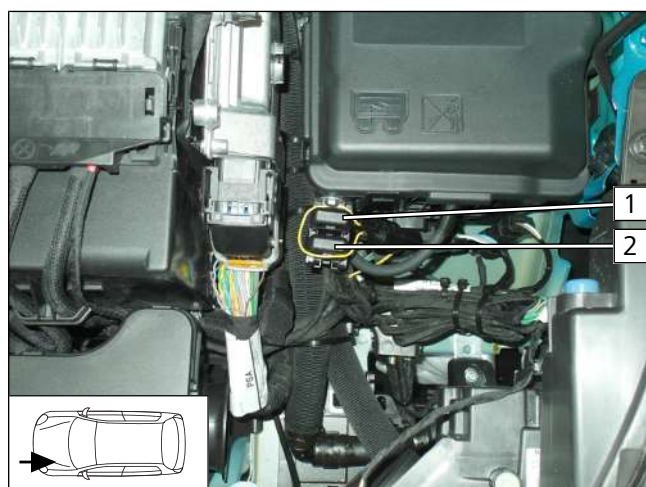
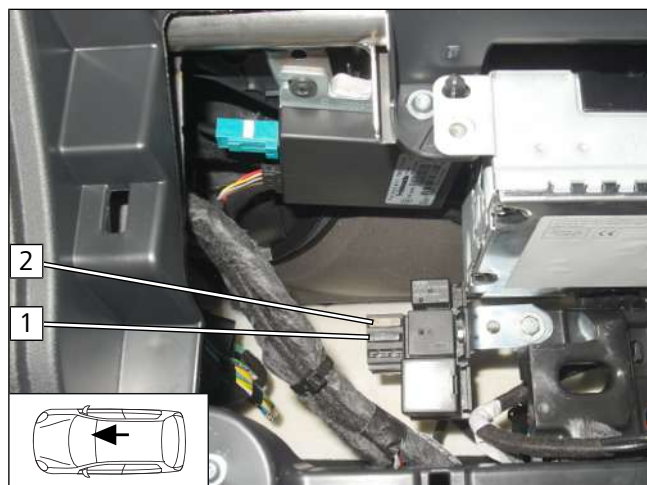

Fig. 111

- 1 F2 - 30A passenger compartment main fuse
- 2 F1 - 20A heater main fuse

Fuses in passenger compartment



- 1 F3 - control element fuse
- 2 F4 - 25A fan controller fuse

Fig. 112