



Water Heater

Thermo Top Evo Parking Heater



With FuelFix

Installation Documentation Citroen C3 / DS3

Validity

Manufacturer	Model	Type	EG BE No. / ABE
Citroen	C3 / DS3	S	e2 * 2007 / 116 * 0003 * ...

Motorisation	Fuel	Transmission type	Output in kW	Displacement in cm ³	Engine code
1.6 blue HDI	Diesel	SG	73	1560	BH02
1.6 blue HDI	Diesel	SG	88	1560	BH01

SG = manual transmission

From model year 2016
Left-hand drive vehicle

Verified equipment variants: Automatic air-conditioning
Xenon headlights
Front fog lights
LED daytime running lights
Start - Stop

Not verified: Manual air-conditioning
Headlight washer system

Total installation time: approx. 10.5 hours

Table of Contents

Validity	1	Preparing Installation Location	16
Necessary Components	2	Preparing Heater	17
Installation Overview	2	Installing Heater	19
Information on Total Installation Time	2	Fuel	20
Information on Operating and Installation Instructions	3	Installing FuelFix	22
Information on Validity	4	Coolant Circuit	25
Technical Information	4	Exhaust Gas	29
Explanatory Notes on Document	4	Final Work	31
Preliminary Work	5	FuelFix Template	32
Heater Installation Location	5	Operating Instructions for Automatic A/C	33
Preparing Electrical System	6		
Electrical System	9		
Fan Controller	10		
MultiControl CAR Option	14		
Remote Option (Telestart)	14		
ThermoCall Option	15		

Necessary Components

- Basic delivery scope of Thermo Top Evo based on price list
- Installation kit with FuelFix for Citroen C3 / DS3 2016 Diesel: **1324599A**
- Heater control in accordance with price list and upon consultation with end customer
- In case of Telestart, indicator lamp in accordance with price list and in consultation with end customer

Installation instructions:

- Arrange for the vehicle to be delivered with the tank only about ¼ full.
- The installation location of the push button in case of Telestart or Thermo Call should be confirmed with the end customer.
- Depending on the space required and the vehicle manufacturer's instructions, we recommend the use of a vehicle battery with a higher electrical capacity.

Installation Overview

Legend:

1. Heater
2. Engine compartment fuse holder
3. Passenger compartment relay and fuse holder
4. Circulating pump
5. Relay K2
6. PWM GW
7. MultiControl CAR
8. Metering pump
9. FuelFix

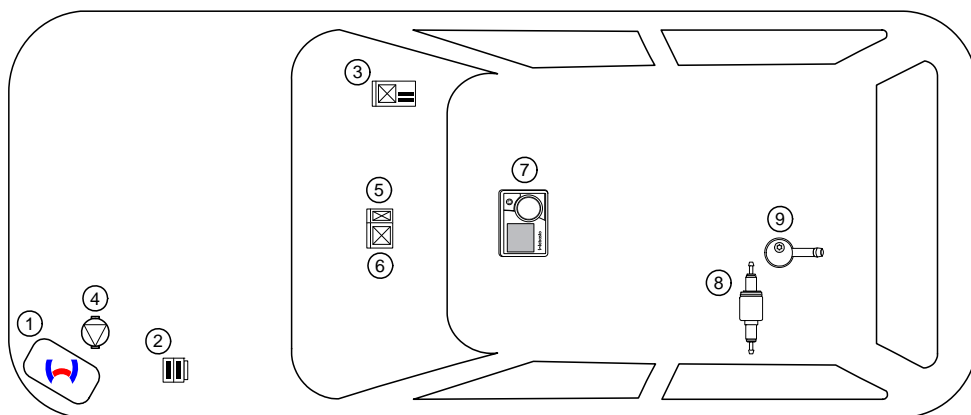

Information on Total Installation Time

The total installation time includes the time needed for mounting and demounting the vehicle-specific components, the heater specific installation time and all other times required for the system integration and initial start-up of the heater. The total installation time may vary for vehicle equipment other than provided.

Information on Operating and Installation Instructions

1 Important information (not complete)

1.1 Installation and repair



The improper installation or repair of Webasto heating and cooling systems can cause fire or the leakage of deadly carbon monoxide, leading to serious injury or death.



To install and repair Webasto heating and cooling systems you need to have completed a special company training course and have the appropriate technical documentation, special tools and special equipment.



Installation and repair may ONLY be carried out by persons trained and certified in a Webasto training course. NEVER try to install or repair Webasto heating or cooling systems if you have not completed a Webasto training course, you do not have the necessary technical skills and you do not have the technical documentation, tools and equipment available to ensure that you can complete the installation and repair work properly.

Only use genuine Webasto parts. See the Webasto air and water heaters accessories catalogue for this purpose.

1.2 Operation

To ensure safe operation, we recommend having the heater checked every two years by an authorised Webasto dealer, especially when used over a long period and/or under extreme environmental conditions.

Do not operate the heater in closed rooms due to the danger of poisoning and suffocation.

Always switch off the heater before refuelling.

The heater may only be used with the prescribed fuel diesel (DIN EN 590) or petrol (DIN EN 228).

The heater may not be cleaned with a high-pressure cleaner.

1.3 Please note

ALWAYS follow all Webasto installation and operating instructions and observe all warnings.

To become familiar with and understand all functions and properties of the heater, the operating instructions must be read carefully and observed at all times.

For proper, safe installation and repair work, the installation instructions with all warnings and safety information must be carefully read and observed at all times. Please always contact a workshop authorised by Webasto for all installation and repair work.

Important

Webasto shall assume no liability for defects, damage and injuries resulting from a failure to observe the installation, repair and operating instructions of the information contained in them.

This liability exclusion particularly applies to improper installations and repairs, installations and repairs by untrained persons or in the case of a failure to use genuine spare parts.

The liability due to culpable disregard to life, limb or health and due to damage or injuries caused by a wilful or reckless breach of duty remain unaffected, as does the obligatory product liability.

Installation should be carried out according to the general, standard rules of technology. Unless specified otherwise, fasten hoses, lines and wiring harnesses to original vehicle lines and wiring harnesses using cable ties. Insulate loose wire ends and tie back. Connectors on electronic components have to audibly click into place during installation.

Sharp edges should be fitted with rub protection. Spray unfinished body areas, e.g. drilled holes, with anti-corrosion wax (Tectyl 100K).

Observe the instructions and guidelines of the respective vehicle manufacturer for demounting and mounting vehicle specific components!

The initial startup is to be executed with the Webasto Thermo Test Diagnosis.

When installing a programmable control module (e.g. a PWM Gateway), the corresponding settings must be checked or adjusted.

2 Statutory regulations governing installation

Guidelines	Thermo Top Evo
Heating Directive ECE R122	E1 00 0258
EMC Directive ECE R10	E1 04 5627

Note

The regulations of these guidelines are binding in the scope of the Directive 70/156/EEC and/or 2007/46/EC (for new vehicle models from 29/04/2009) and should also be observed in countries in which there are no special regulations.

Important

Failure to follow the installation instructions will result in the invalidation of the type approval for the heater and therefore invalidation of the general **homologation of the vehicle**.

Note

The heater is licensed in accordance with paragraph 19, section 3, No. 2b of the StVZO (German Road Traffic Licensing Authority).

2.1 Excerpt from ECE regulation 122 (heating system) paragraph 5 for the installation of the heater

Beginning of excerpt.

ANNEX VII

REQUIREMENTS FOR COMBUSTION HEATERS AND THEIR INSTALLATION

1. GENERAL REQUIREMENTS

1.7.1. A clearly visible tell-tale in the operator's field of view shall inform when the combustion heater is switched on or off.

2. VEHICLE INSTALLATION REQUIREMENTS

2.1. Scope

2.1.1. Subject to paragraph 2.1.2, combustion heaters shall be installed according to the requirements of this Annex.

2.1.2. Vehicles of category O having liquid fuel heaters are deemed to comply with the requirements of this Annex.

2.2. Positioning of heater

2.2.1. Body sections and any other components in the vicinity of the heater must be protected from excessive heat and the possibility of fuel or oil contamination.

2.2.2. The combustion heater shall not constitute a risk of fire, even in the case of overheating. This requirement shall be deemed to be fulfilled if the installation ensures an adequate distance to all parts and suitable ventilation, by the use of fire resistant materials or by the use of heat shields.

2.2.3. In the case of M2 and M3 vehicles, the heater must not be positioned in the passenger compartment. However, an installation in an effectively sealed envelope which also complies with the conditions in paragraph 2.2.2 may be used.

2.2.4. The label referred to in paragraph 1.4 or a duplicate, must be positioned so that it can be easily read when the heater is installed in the vehicle.

2.2.5. Every reasonable precaution should be taken in positioning the heater to minimise the risk of injury and damage to personal property.

2.3. Fuel supply

2.3.1. The fuel filler must not be situated in the passenger compartment and must be provided with an effective cap to prevent fuel spillage.

2.3.2. In the case of liquid fuel heaters, where a supply separate to that of the vehicle is provided, the type of fuel and its filler point must be clearly labelled.

2.3.3. A notice, indicating that the heater must be shut down before refuelling, must be affixed to the fuelling point. In addition a suitable instruction must be included in the manufacturer's operating manual.

2.4. Exhaust system

2.4.1. The exhaust outlet must be located so as to prevent emissions from entering the vehicle through ventilators, heated air inlets or opening windows.

2.5. Combustion air inlet

2.5.1. The air for the combustion chamber of the heater must not be drawn from the passenger compartment of the vehicle.

2.5.2. The air inlet must be so positioned or guarded that blocking by rubbish or luggage is unlikely.

2.6. Heating air inlet

2.6.1. The heating air supply may be fresh or recirculated air and must be drawn from a clean area not likely to be contaminated by exhaust fumes emitted either by the propulsion engine, the combustion heater or any other vehicle source.

2.6.2. The inlet duct must be protected by mesh or other suitable means.

2.7. Heating air outlet

2.7.1. Any ducting used to route the hot air through the vehicle must be so positioned or protected that no injury or damage could be caused if it were to be touched.

2.7.2. The air outlet must be so positioned or guarded that blocking by rubbish or luggage is unlikely.

End of excerpt.

In multilingual versions the German language is binding.

Information on Validity

This installation documentation applies to Citroen C3 / DS3 Diesel vehicles - for validity, see page 1 - from model year 2016 and later, assuming technical modifications to the vehicle do not affect installation, any liability claims excluded. Depending on the vehicle version and equipment, modifications may be necessary during installation with respect to this 'installation documentation'.

Vehicle and engine types, equipment variants and other specifications not listed in this installation documentation have not been tested. However, installation according to this installation documentation may be possible.

Technical Information

Special Tools

- Hose clamp pliers for auto-tightening hose clamps
- Hose clamp pliers for Clic hose clamps of type W
- Automatic wire stripper 0.2 - 6mm²
- Crimping pliers for cable lug / tab connector 0.5 - 6mm²
- Torque wrench for 2.0 - 10 Nm
- Hose clamping pliers
- Metric thread-setter kit
- Deep-hole marker
- Webasto Thermo Test Diagnosis with current software

Dimensions

- All dimensions are in mm.

Tightening torque values

- Tightening torque values of 5x13 heater bolts and 5x11 heater stud bolts = 8Nm.
- Tightening torque value of 5x15 water connection piece retaining plate bolt = 7Nm.
- Tighten other bolt connections in accordance with manufacturer's instructions or in accordance with state-of-the-art technology.

Explanatory Notes on Document

You will find an identification mark on the outside top right corner of the page in question to provide you with a quick overview of the individual working steps.

Special features are highlighted using the following symbols:

Mechanical System



Electrical System



Coolant Circuit



Combustion Air



Fuel



Exhaust Gas



Software



Specific risk of damage to components.



Specific risk due to electrical voltage.



Specific risk of injury or fatal accidents.



Specific risk of fire or explosion.



Reference to the manufacturer's vehicle-specific documents or to the general installation instructions of Webasto components.



Reference to a special technical feature.



The arrow in the vehicle icon indicates the position on the vehicle and the viewing angle.



Tightening torque according to the manufacturer's vehicle-specific documents.



Preliminary Work

Vehicle



- Open the fuel tank cap.
- Ventilate the fuel tank.
- Close the fuel tank cap again.
- Depressurise the cooling system.
- Disconnect and completely remove the battery together with the carrier.
- Detach the control unit and put it aside.
- Remove the charge-air tube.
- Detach the wheel well trim on the right and left.
- Remove the bumper trim.
- Remove the right-hand underbody trim.
- Remove the front underride protection.
- Remove the left-hand headlight.
- Remove the instrument panel trim in the footwell on the driver's side.
- Remove the instrument panel trim on the left (only in case of Telestart T100 HTM).
- Remove the wheel/A/C control panel in accordance with the manufacturer's instructions.

The following work should only be performed during the corresponding installation sequence:

- Remove the rear bench seat.
- Open the right-hand tank-fitting service lid.

Heater

- Remove years that do not apply from the type and duplicate label.
- Attach the duplicate label (type label) visibly in the appropriate place in the engine compartment.

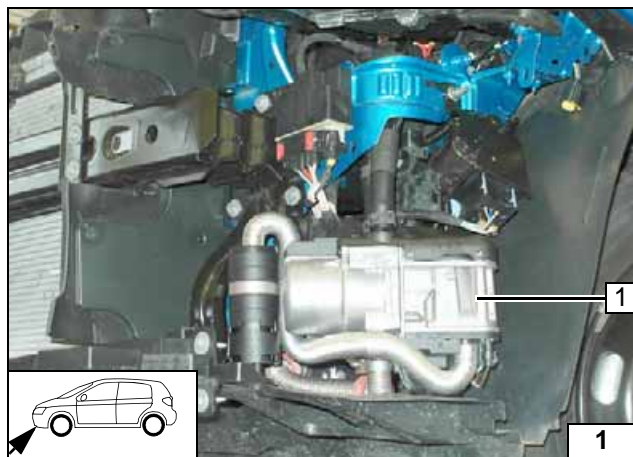

Heater Installation Location

- 1 Heater

Installation location

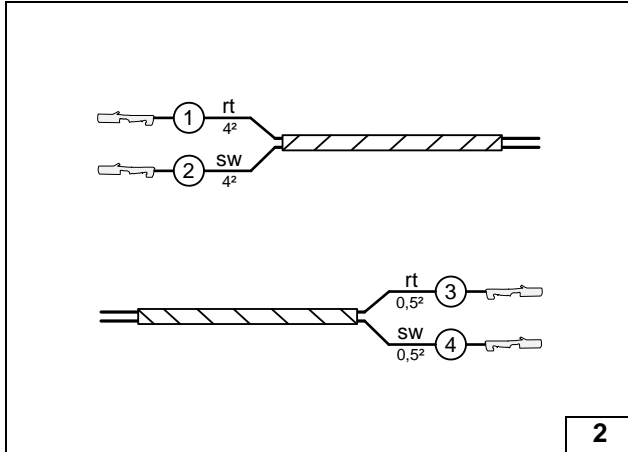
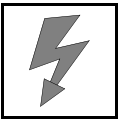

Preparing Electrical System

Wire sections retain their numbering in the entire document.

Produce all following electrical connections as shown in the wiring diagram.

- ① Red (rt) wire of fan wiring harness
- ② Black (sw) wire of fan wiring harness
- ③ Red (rt) wire from wiring harness of PWM control
- ④ Black (sw) wire from wiring harness of PWM control

Assigning wires

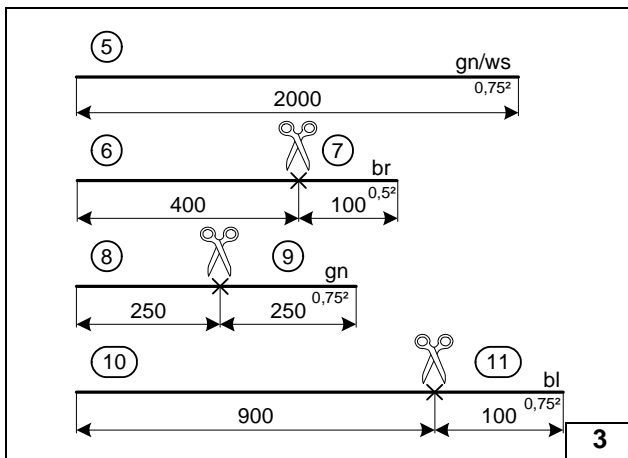

Cut off 1700mm of protective sleeving. Pull green/white (gn/ws) wire ⑤ into 1700mm protective sleeving. Pull wire section ⑩ into 800 mm protective sleeving.

Cutting to length / assigning wires

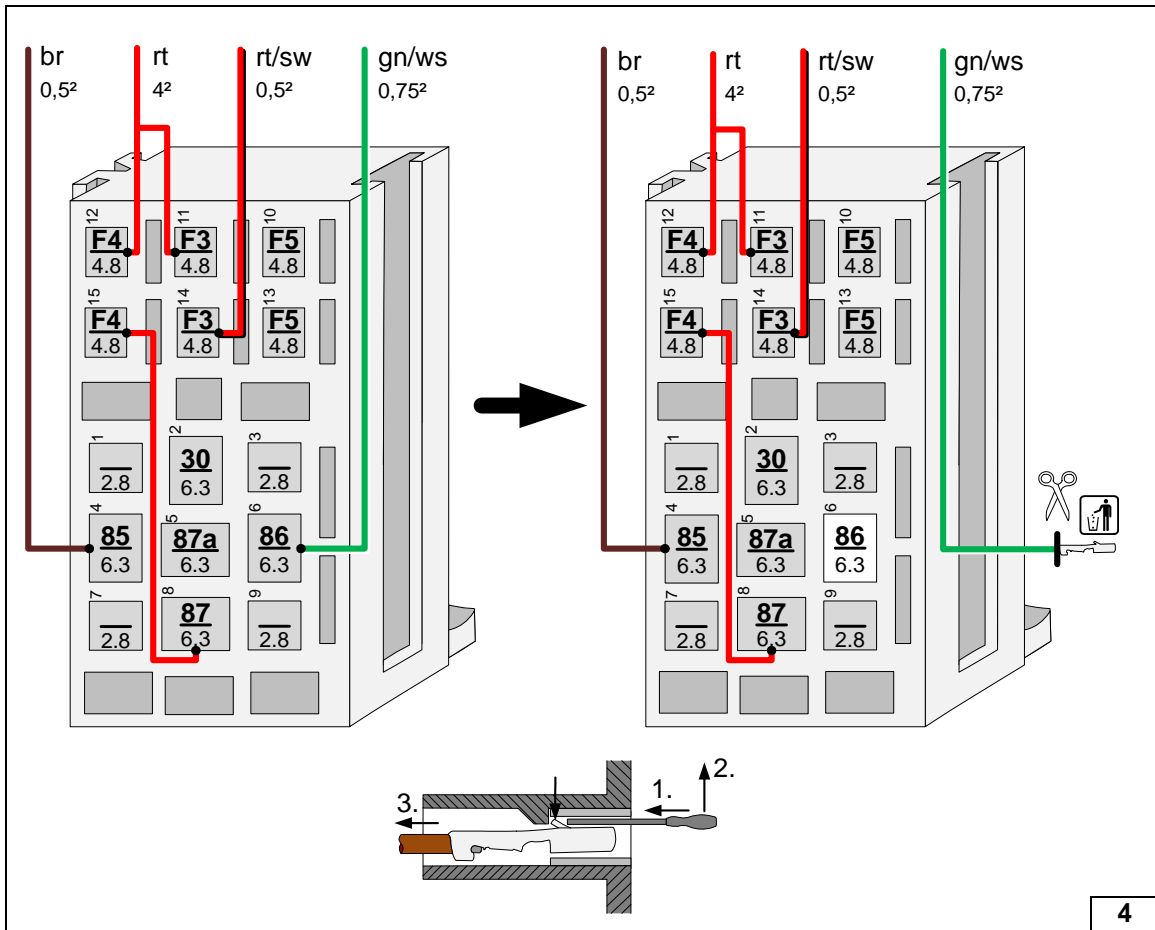

Preparing passenger compartment relay and fuse holder

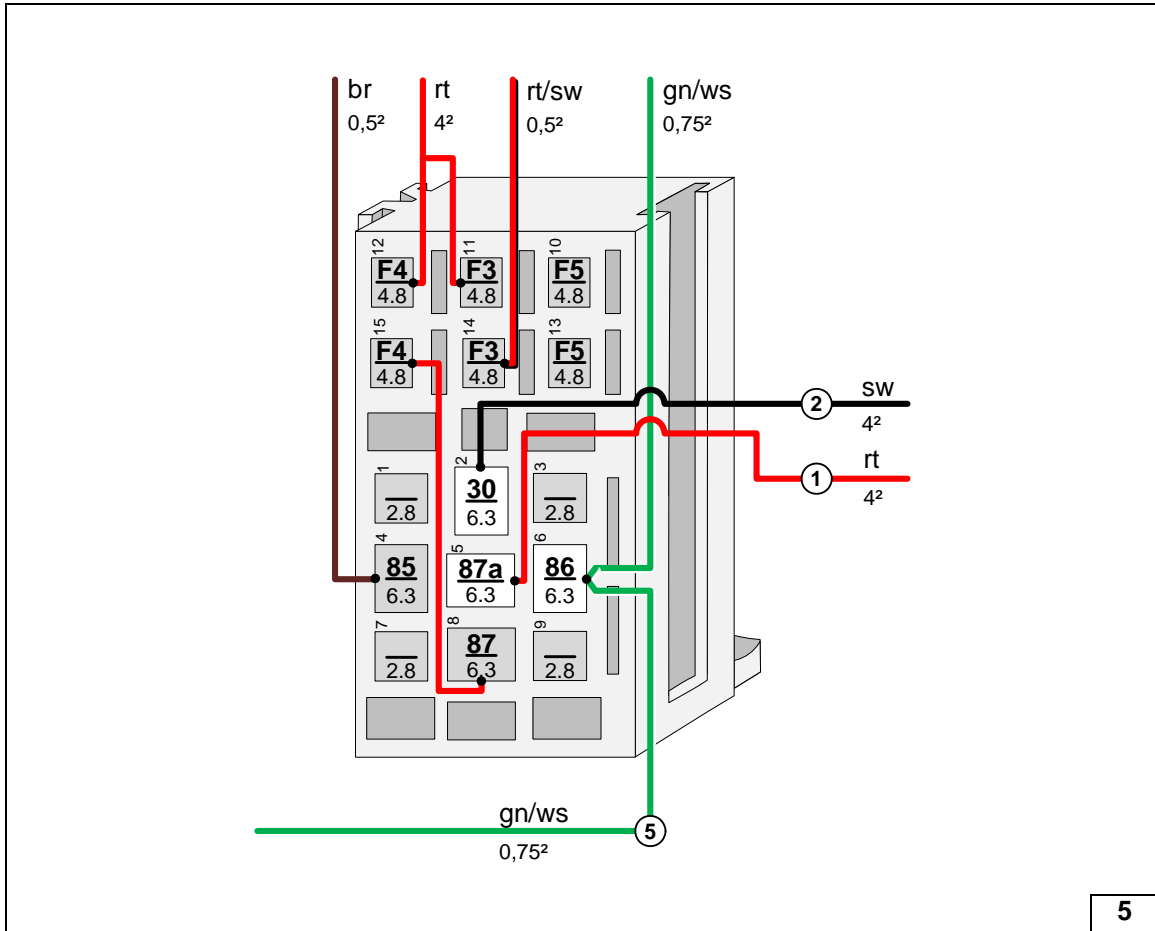
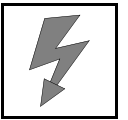

Connecting wires to passenger compartment relay and fuse holder

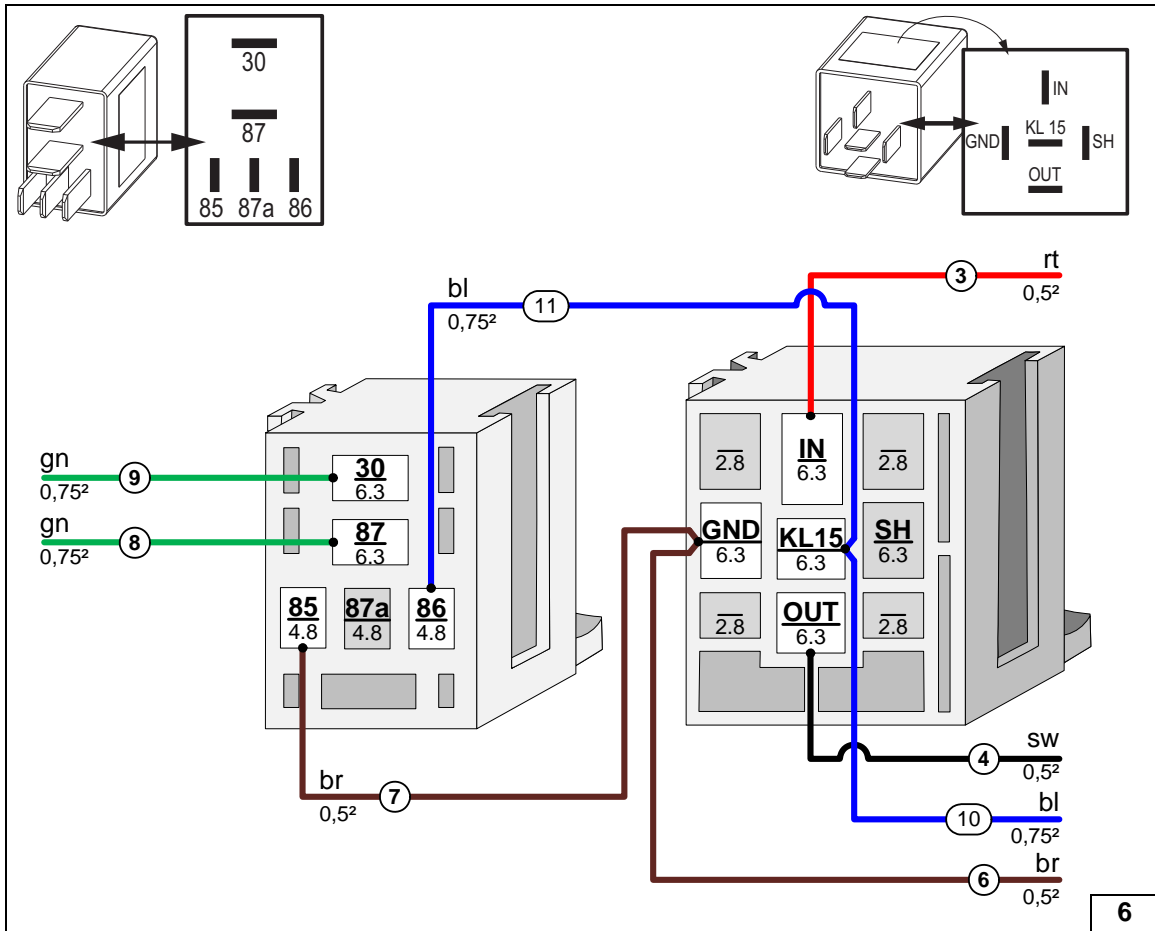

Connecting wires to PWM GW socket and relay K2

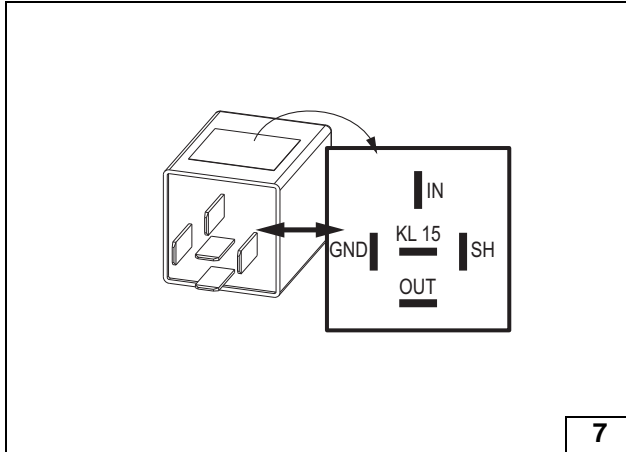
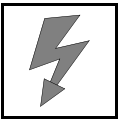

Check the PWM Gateway settings when starting up the heater and adjust if necessary.

Settings:

Duty cycle: 27%
 Frequency: 400Hz
 Voltage: not relevant
 Function: Low side



View of PWM GW

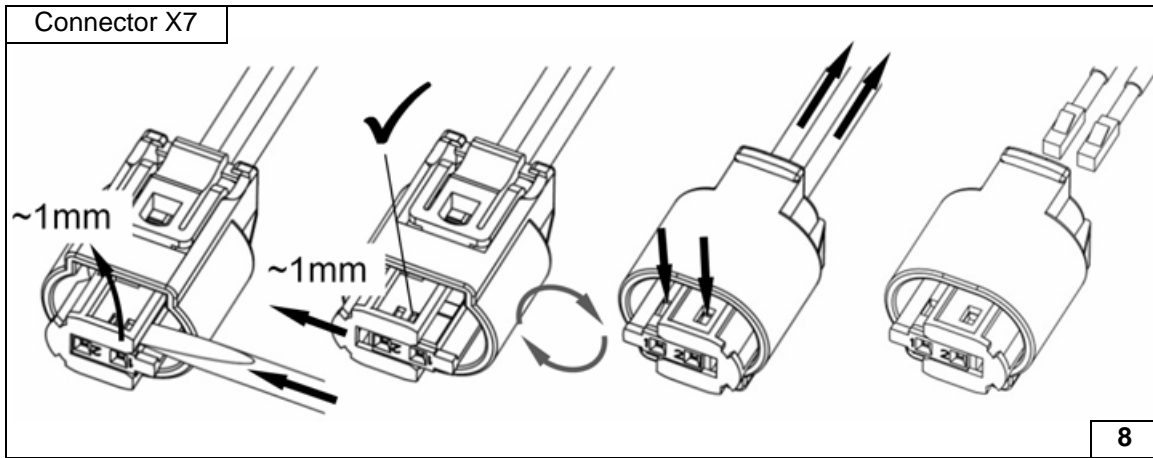

Dismantling metering pump connector



Electrical System



Wiring harness routing

- 1 Coolant reservoir protective rubber plug
- 2 Wiring harnesses of heater, heater control
- 3 Route heater, heater control wiring harnesses to the right side of the vehicle

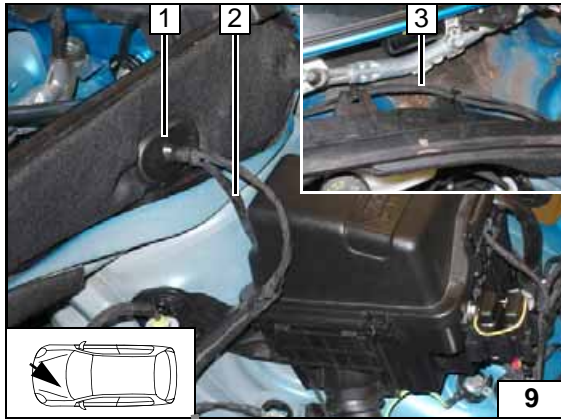

Wiring harness pass through

- 1 Protective rubber plug
- 2 Wiring harnesses of heater, heater control

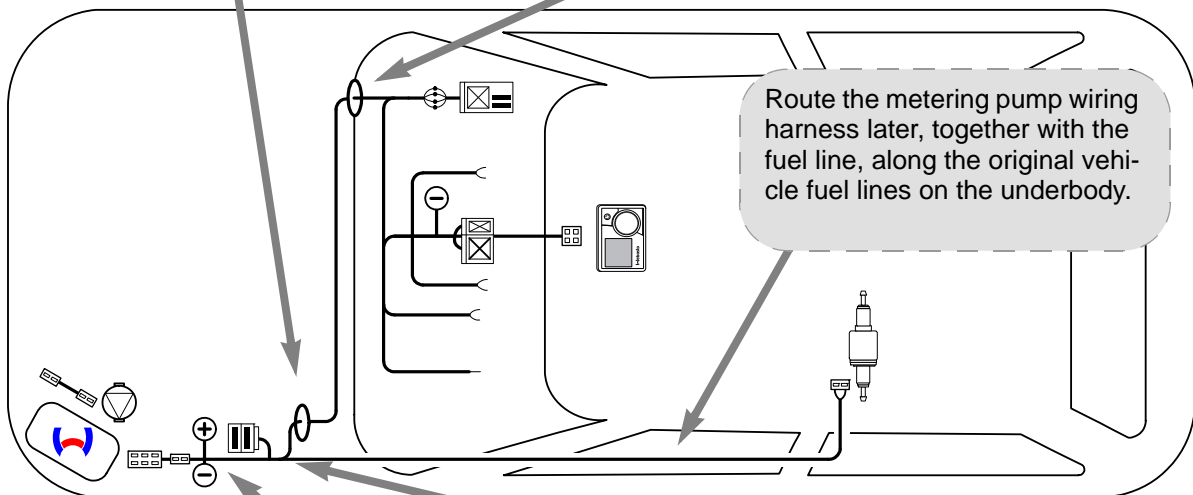
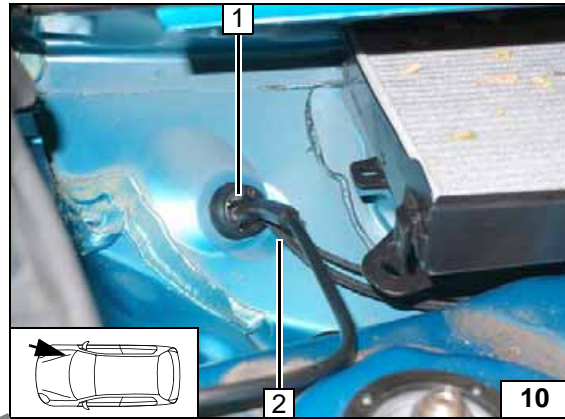

Wiring harness routing diagram

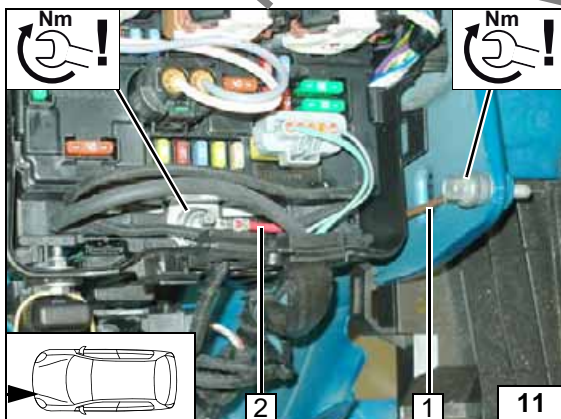

Positive and earth wire

- 1 Earth wire on original vehicle earth support point
- 2 Positive wire on original vehicle positive support point

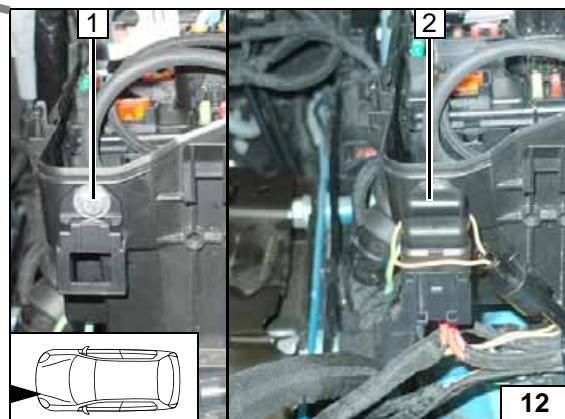

Engine compartment fuse holder

- 1 6mm dia. hole; M5x16 bolt, large diameter washer [2x], retaining plate of fuse holder, nut
- 2 Fuses F1-2



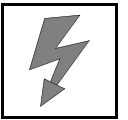

Fan Controller

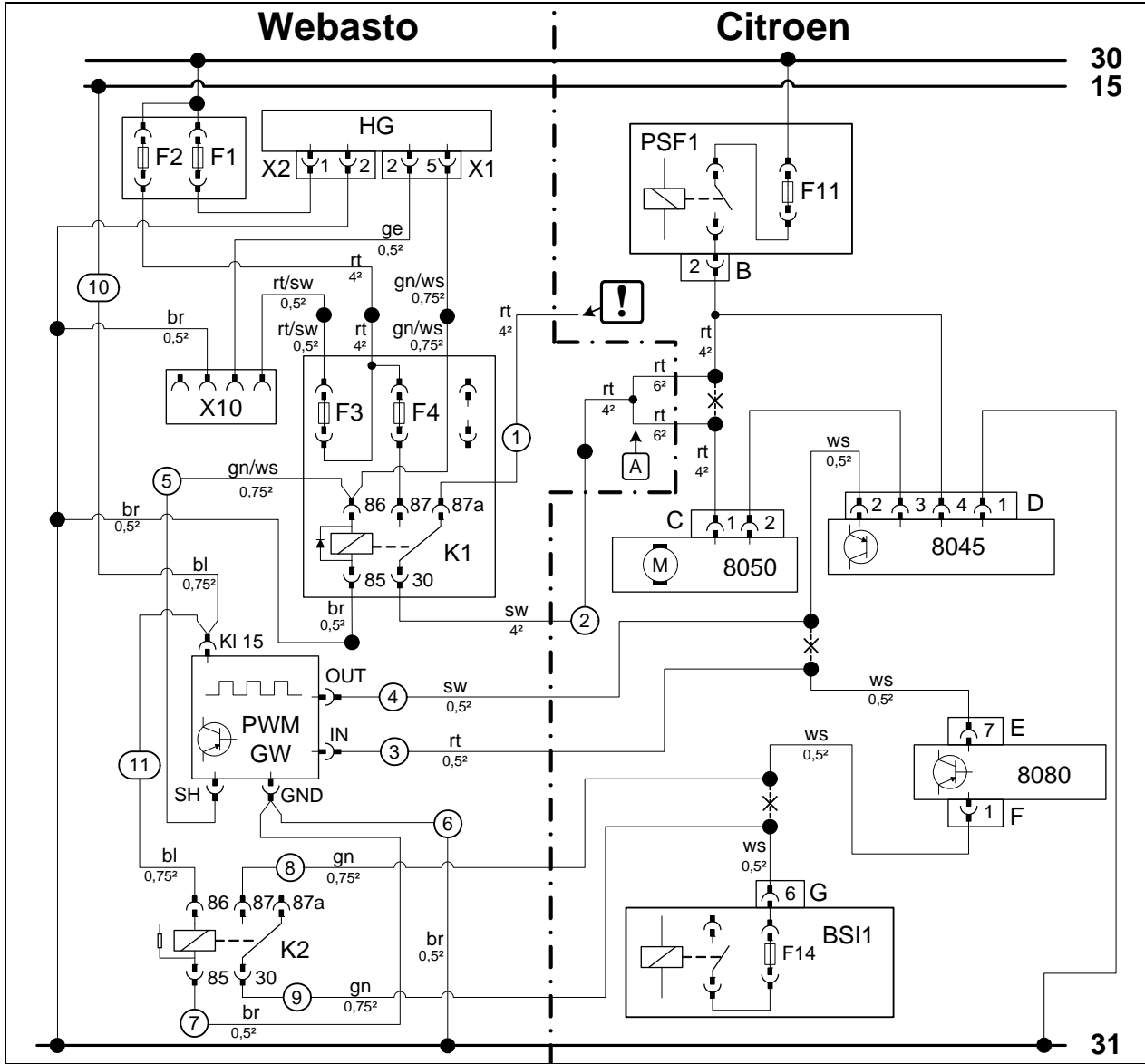

Wiring diagram

Webasto components		Vehicle components		Colours and symbols	
HG	TT-Evo heater	PSF1	Engine compartment fuse box	rt	red
X1	6-pin heater connector	F11	Fuse	ws	white
X2	2-pin heater connector	B	2V connector NR	sw	black
F1	20A fuse	8045	Fan controller	br	brown
F2	30A fuse	D	4V connector NR	bl	blue
F3	1A fuse	8050	Fan motor	gn	green
F4	25A fuse	8080	A/C control unit	ge	yellow
X10	4-pin connector of heater control	C	2V connector NR		
K1	Fan relay	8080	A/C control unit		
A	Power adapter	E	26V connector JN		
PWM GW	Pulse width modulator	F	6V connector NR		
K2	Additional relay	BSI1	Central switching unit		
PWM GW settings:		F14	Fuse		
Duty cycle: 27%		G	10V connector NR		
Frequency: 400Hz				!	Insulate wire end and tie back
Voltage: not relevant				X	Cutting point
Function: Low side					Wiring colours may vary.

Legend

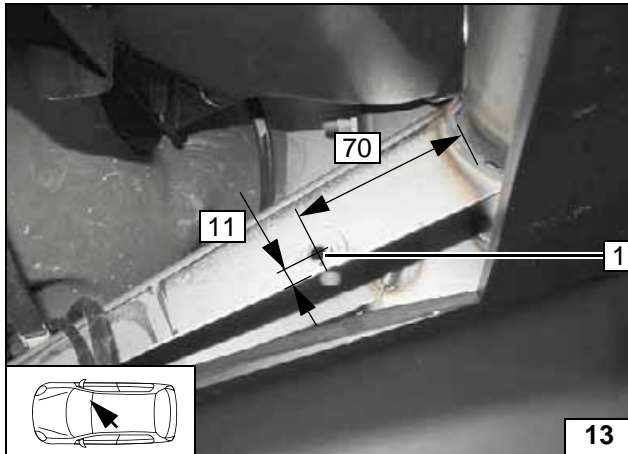
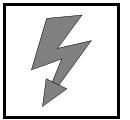

1 5mm dia. hole

Preparing passenger compartment relay and fuse holder installation

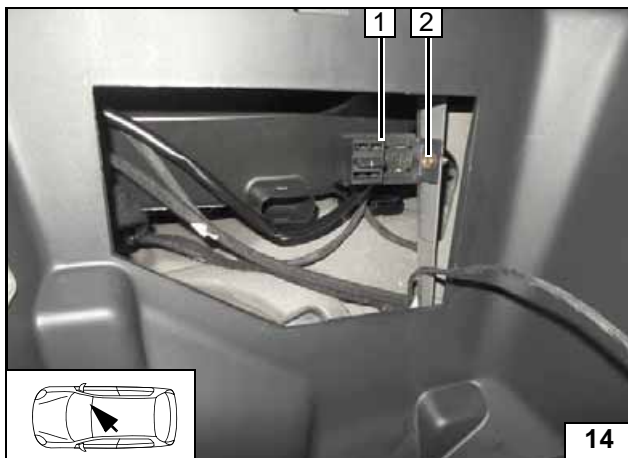

1 Passenger compartment relay and fuse holder
2 6x13 self-tapping screw

Installing passenger compartment relay and fuse holder

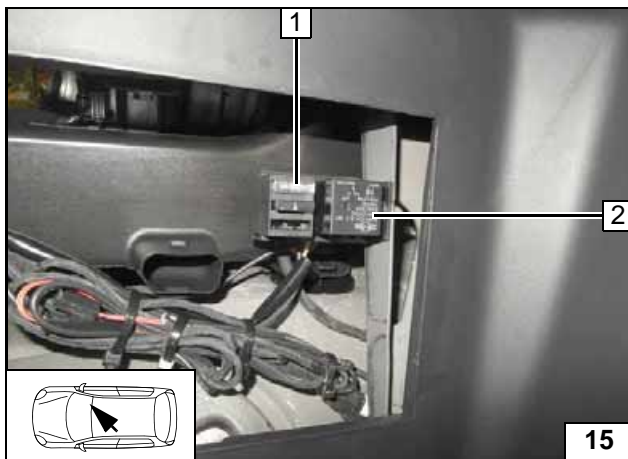

1 Fuse F4
2 Relay K1

Installing relay K1 and fuse F4

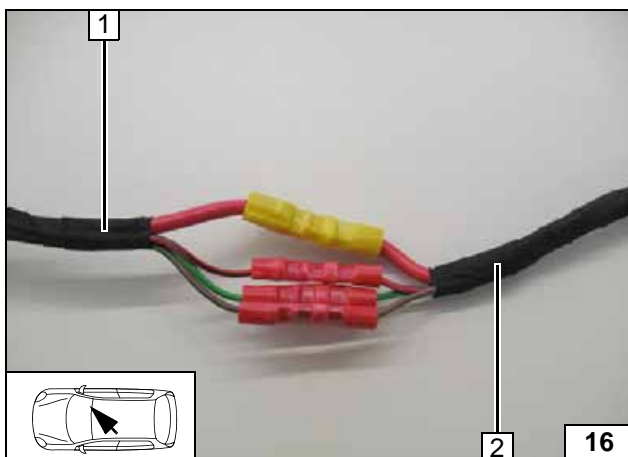

1 Passenger compartment relay and fuse holder wiring harness
2 Heater wiring harness

Connecting same colour wires of wiring harnesses

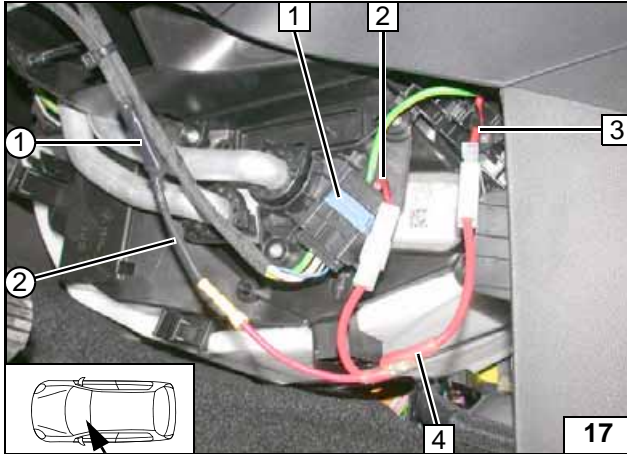
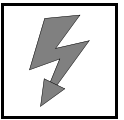

Connection on 6-pin connector IC26 1. Insulate red (rt) wire ① of K1/87a and tie back.

- 2 Red (rt) wire of connector IC26, pin 3
- 3 Red (rt) wire of fan motor
- 4 Power adapter
- ② Black (sw) wire of K1/30



Connect-
ing fan mo-
tor

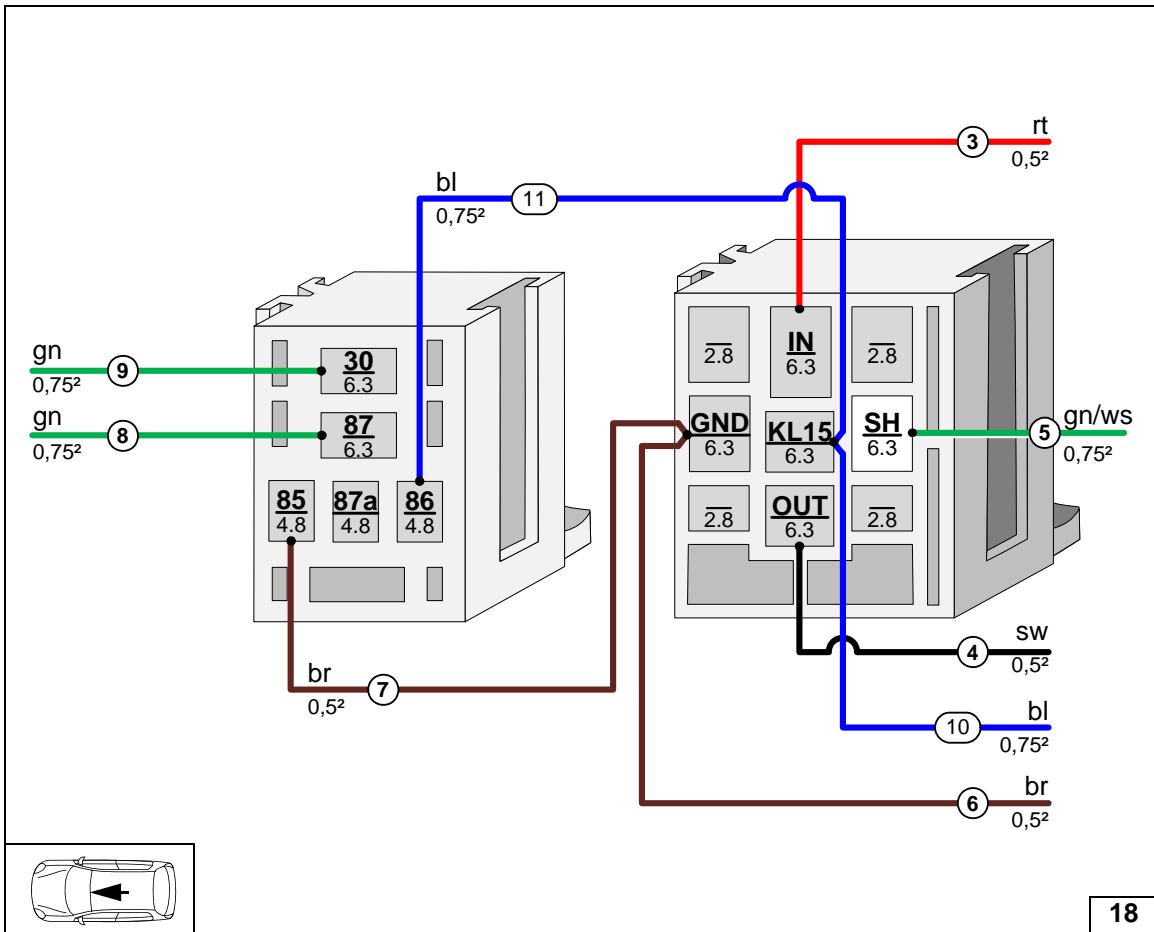

Connecting
wire to PWM
GW socket
in passenger
compartment

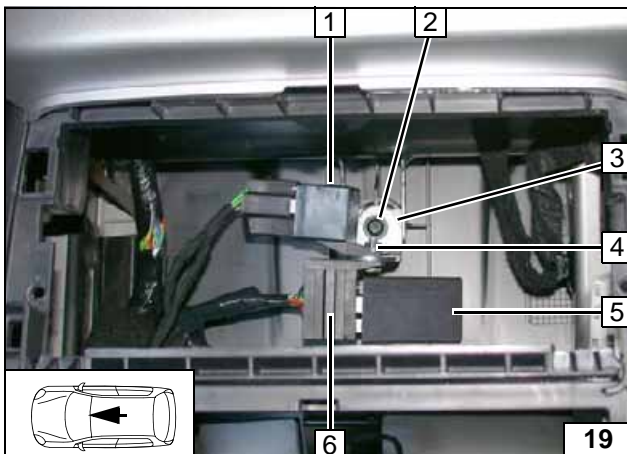

- 1 Relay K2
- 2 Original vehicle bolt
- 3 Angle bracket
- 4 M5x16 bolt, large diameter washer, flanged nut
- 5 PWM GW installed
- 6 PWM GW socket

Installing
relay K2
and PWM
GW

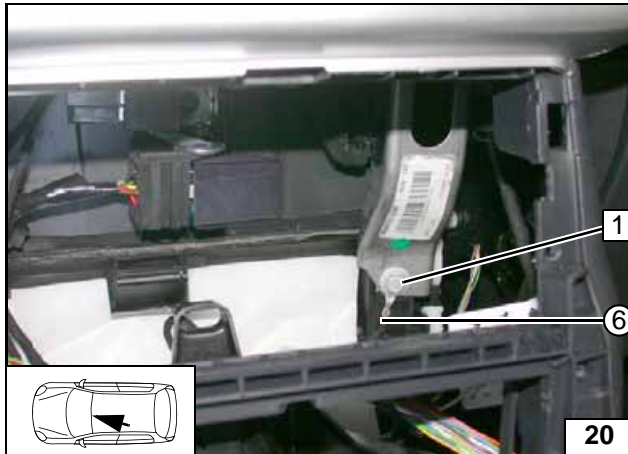

- 1 Original vehicle bolt
- ⑥ Brown (br) wire of PWM GW/85

Relay K2
and PWM
GW earth
connection

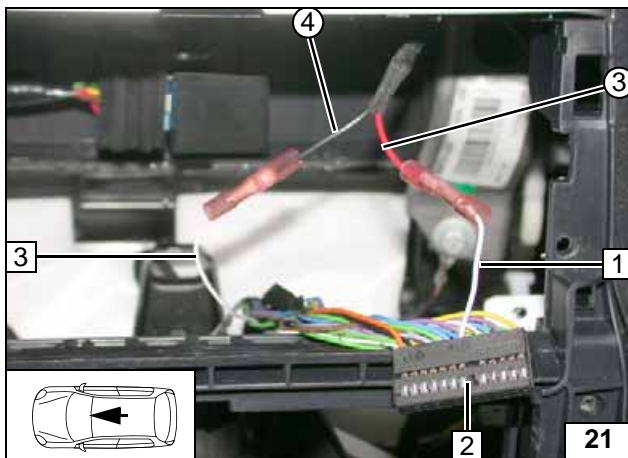

Connection on 26-pin connector 2 from A/C control panel.



- 1 White (ws) wire 26-pin connector pin 7
- 3 White (ws) wire of fan controller
- ③ Red (rt) wire from wiring harness of PWM control
- ④ Black (sw) wire from wiring harness of PWM control

Connect-
ing PWM
GW

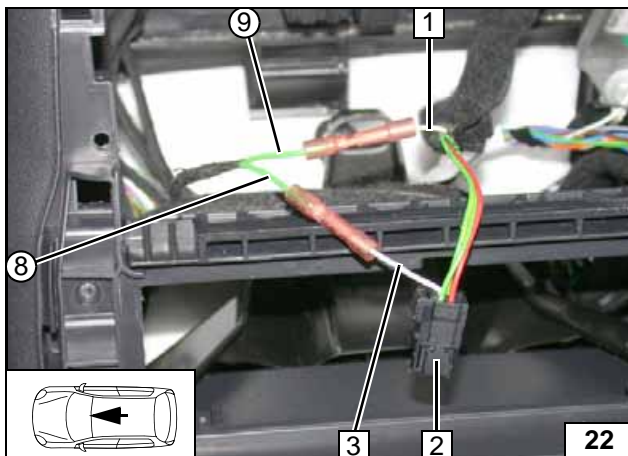

Connection on 6-pin connector 2 from A/C control panel.



- 1 White (ws) wire of BSI
- 3 White (ws) wire of 6-pin connector Pin1
- ⑧ Green (gn) wire of K2/87
- ⑨ Green (gn) wire of K2/30

Connect-
ing relay K2

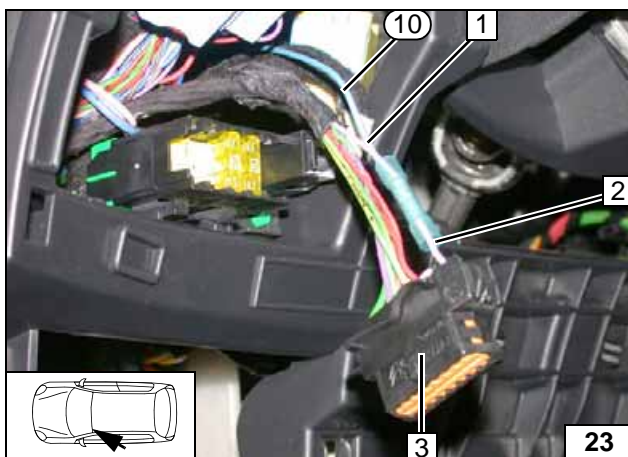

Connection on 16-pin OBD connector 3.



- 1 White (ws) wire of Terminal 15
- 2 White (ws) wire of 16-pin OBD connector Pin1
- ⑩ Blue (bl) wire of PWM GW/15

Connect-
ing terminal
15

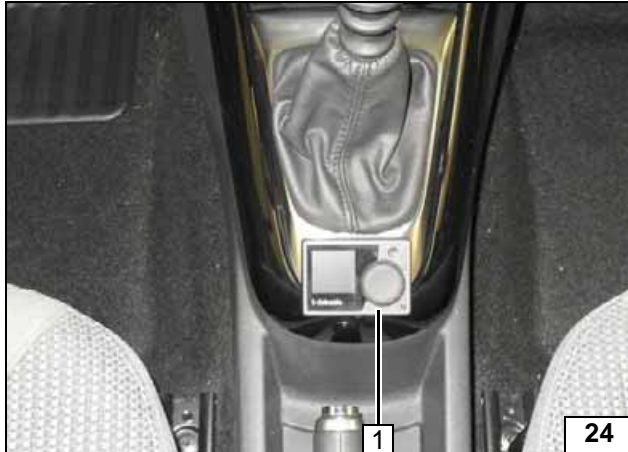
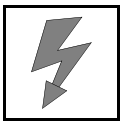

MultiControl CAR Option

- 1 MultiControl CAR



Installing
MultiControl
CAR

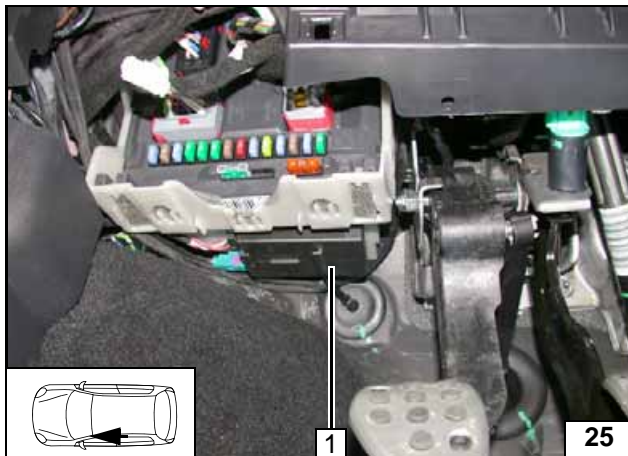

Remote Option (Telestart)

Fasten receiver 1 with double-sided adhesive tape.



Installing
receiver

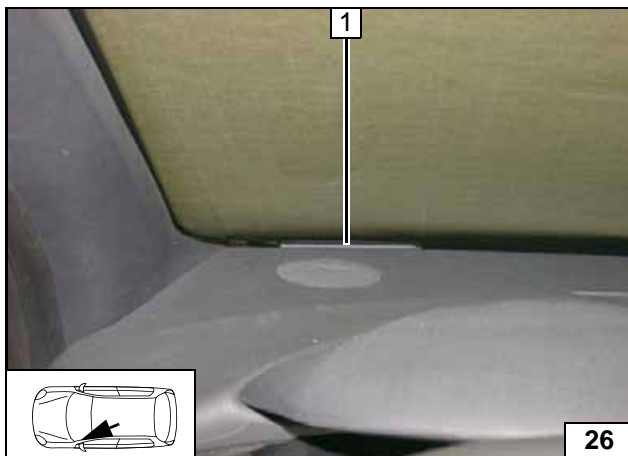

- 1 Aerial

Installing
aerial

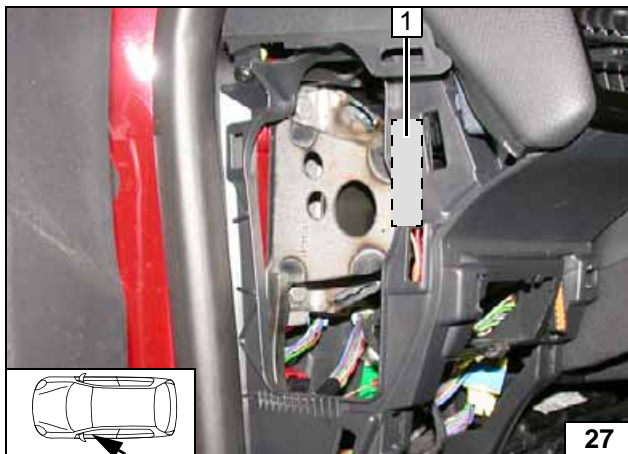

Temperature sensor T100 HTM

Fasten temperature sensor 1 behind the instrument panel trim on the left with double-sided adhesive tape.



Installing
temperature
sensor

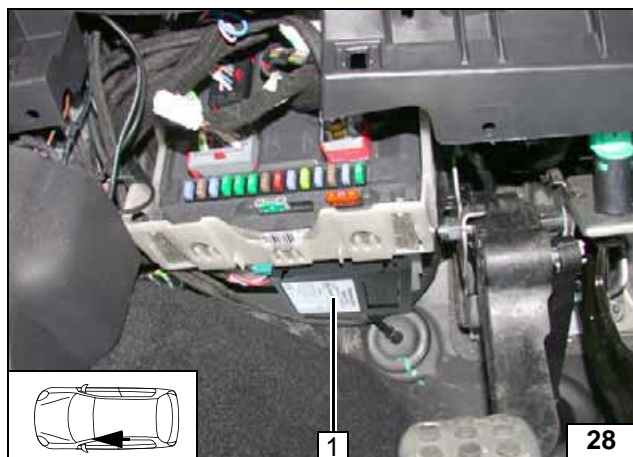
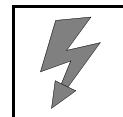

ThermoCall Option

Fasten receiver 1 with double-sided adhesive tape.



Installing receiver

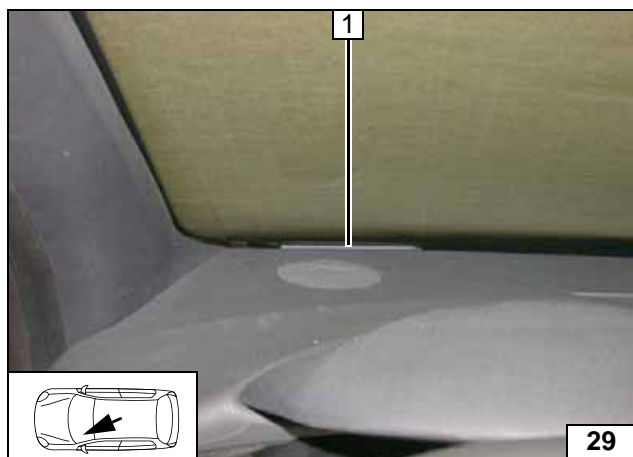

1 Aerial (optional)

Installing aerial

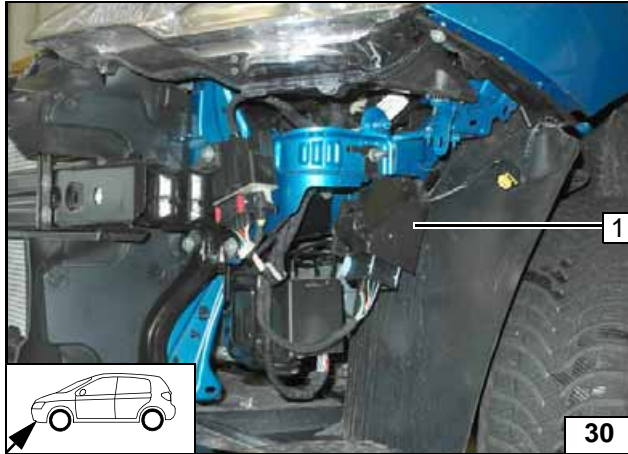
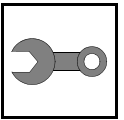

Preparing Installation Location

Dismantle control unit with bracket 1.



Dismantling control unit

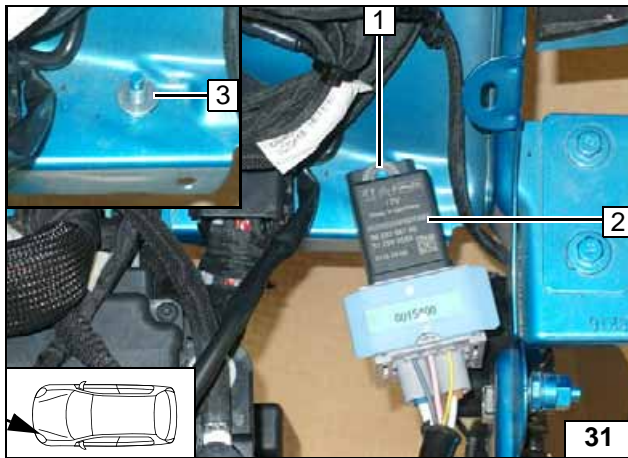

Remove relay 2 at position 1 and install flanged nut 3 with flange upwards. Install relay as shown.

- 1 Original vehicle nut



Positioning relay

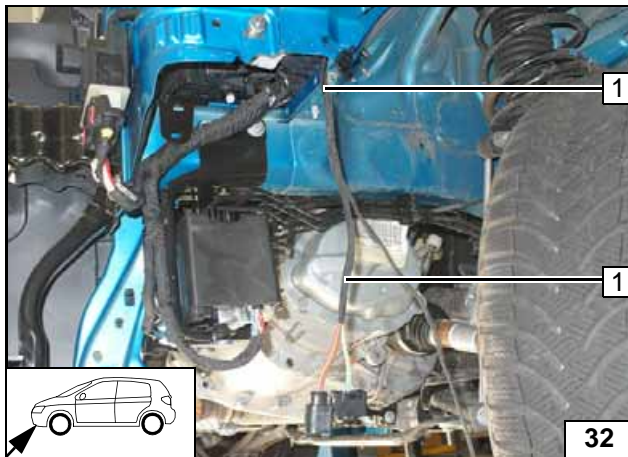

Route wiring harness of heater 1 to installation location.



Routing wiring harness

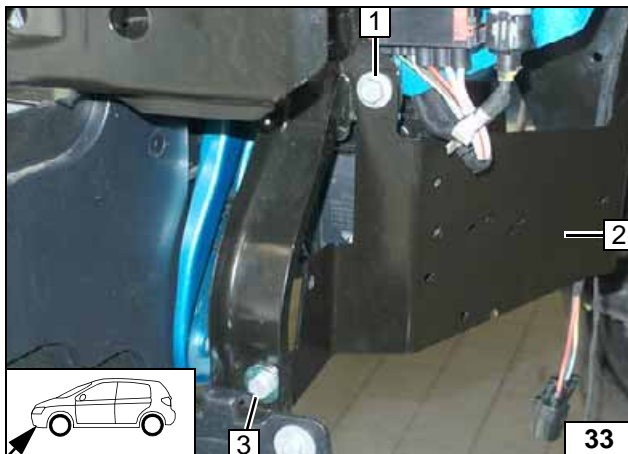

- 1 Original vehicle bolt
- 2 Install bracket loosely
- 3 M8x20 bolt, flanged nut, existing hole

Installing bracket loosely

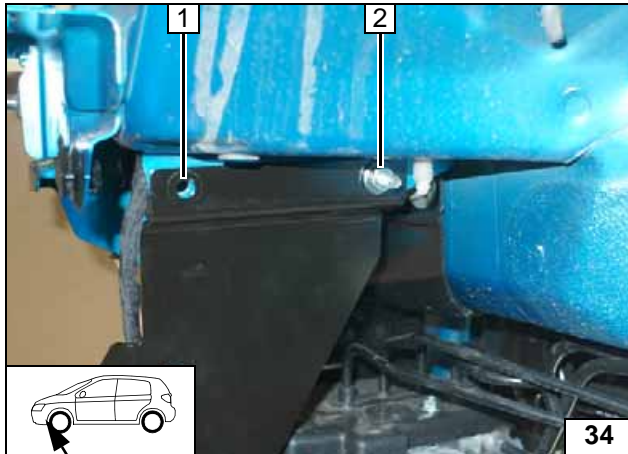
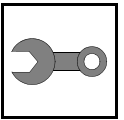

Remove bracket after copying hole pattern at position 1.

- 1 7 mm dia. hole
- 2 M6x20 bolt, flanged nut, existing hole



Copying hole pattern

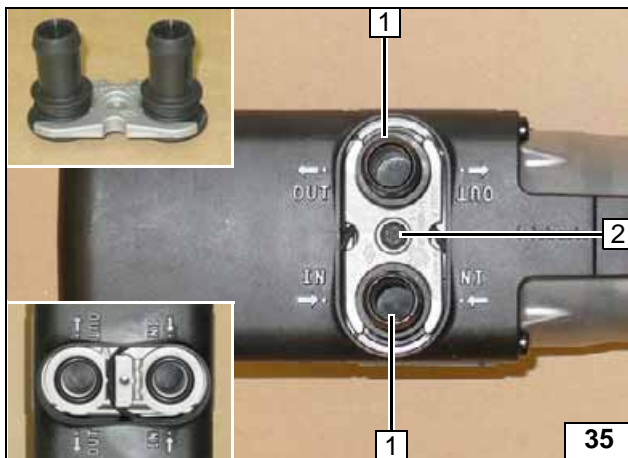

Preparing Heater

- 1 Water connection piece, sealing ring [2x each]
- 2 5x15 self-tapping bolt, retaining plate of water connection piece



Installing water connection piece

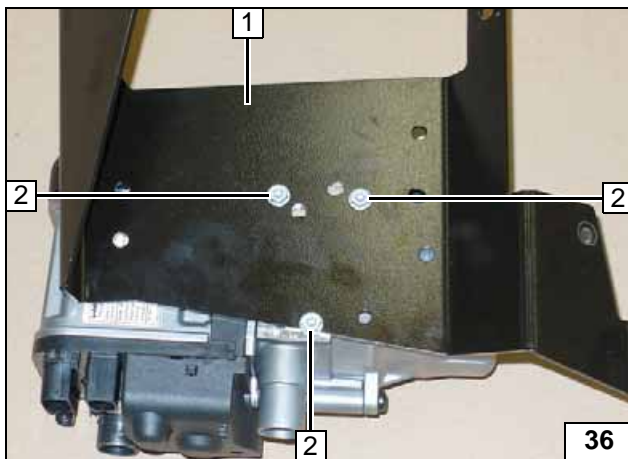

- 1 Bracket
- 2 5x13 self-tapping bolt [3x]

Premounting heater

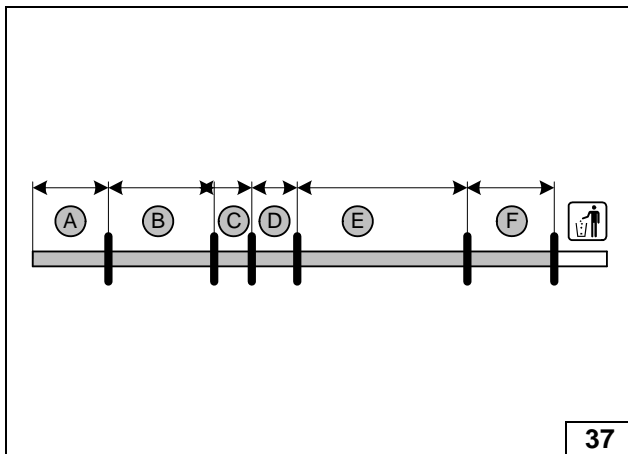

- A = 220
- B = 570
- C = 60
- D = 80
- E = 750
- F = 210

Cutting hoses to length

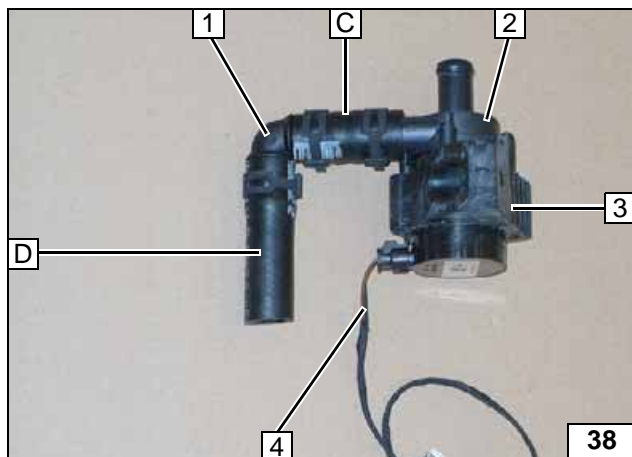
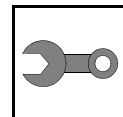

All spring clips = 25mm dia.!

- 1 90°, 18x18 connecting pipe
- 2 Circulating pump
- 3 Circulating pump mount
- 4 Circulating pump wiring harness



Premounting circulating pump

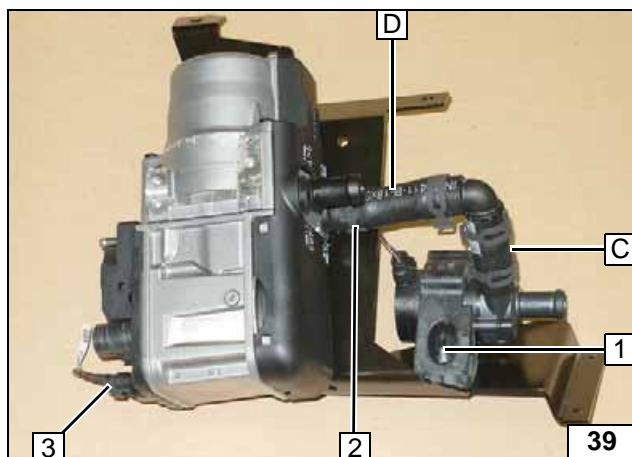

- 1 M6x25 bolt, flanged nut
- 2 25mm dia. spring clips
- 3 Connector of circulating pump wiring harness

Installing circulating pump

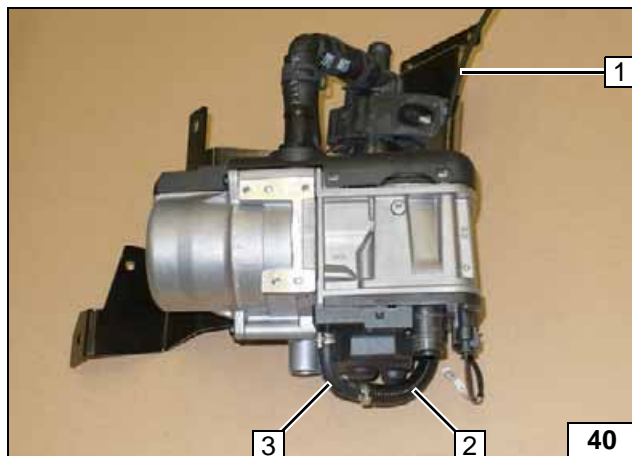

- 1 Fuel line
- 2 250mm long corrugated tube
- 3 90° moulded hose, 10mm dia. clamps [2x]

Installing fuel line



- 1 5x13 self-tapping bolt, p-clamp
- 2 Silencer
- 3 51mm dia. clamps
- 4 Combustion air pipe
- 5 M5x16 bolt, flanged nut

Installing combustion air pipe

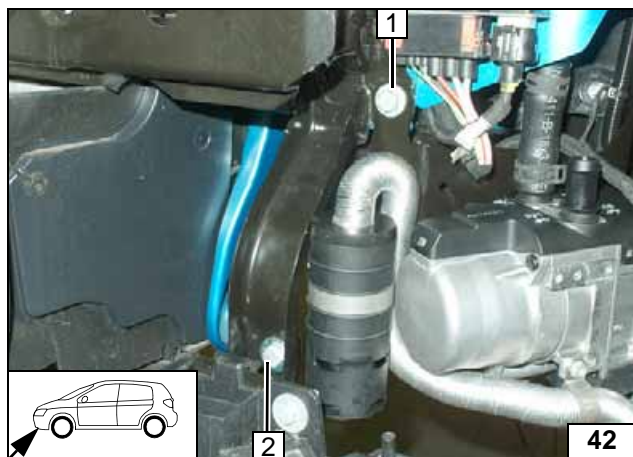
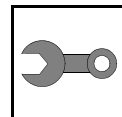

Installing Heater

- 1 Original vehicle bolt
- 2 M8x20 bolt, large diameter washer, flanged nut, existing hole

Installing heater

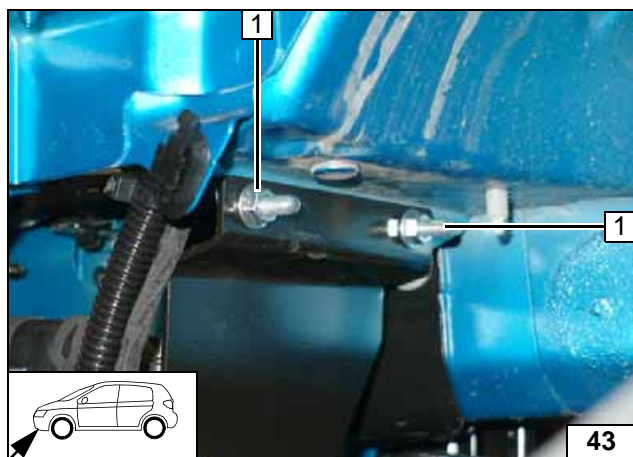

- 1 M6x20 bolt, flanged nut [2x each]

Installing heater

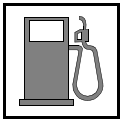

Fuel



Open the vehicle's fuel tank cap, ventilate the tank and then re-close the tank lock.

Catch any fuel running off in an appropriate container.



Route fuel line and metering pump wiring harness so that they are protected against stone impact. Unless specified otherwise, always fasten using cable ties.

Provide rub protection for fuel line and wiring harness in areas where there are sharp edges.

The fuel line and wiring harness are routed to the metering pump as shown in the wiring harness routing diagram.

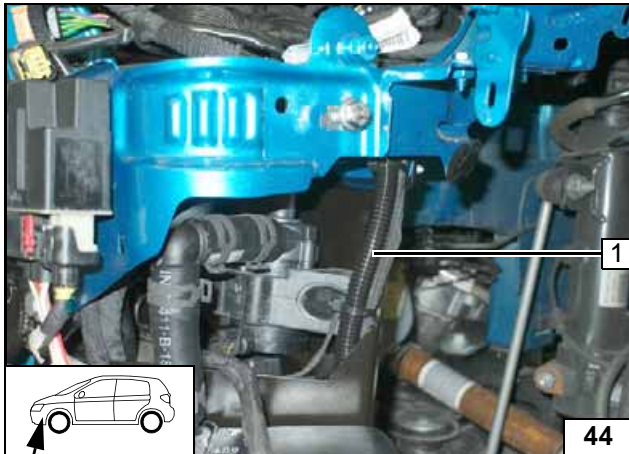

1 Fuel line and wiring harness of metering pump in corrugated tube

Routing of lines in engine compartment



1 Fuel line and wiring harness of metering pump in corrugated tube

Routing lines to underbody

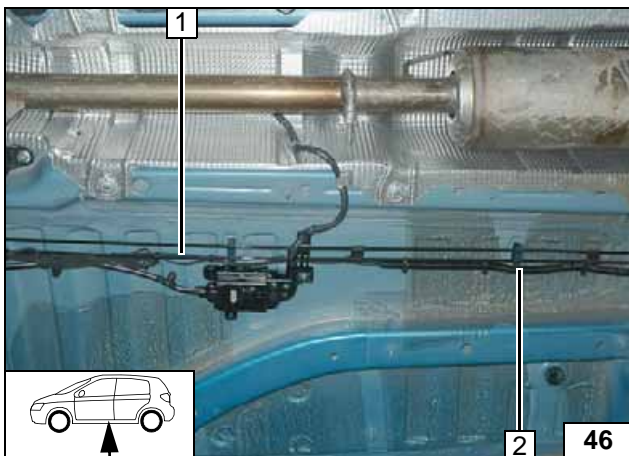

1 Fuel line and metering pump wiring harness
2 Fuel line and wiring harness of metering pump in corrugated tube

Routing lines

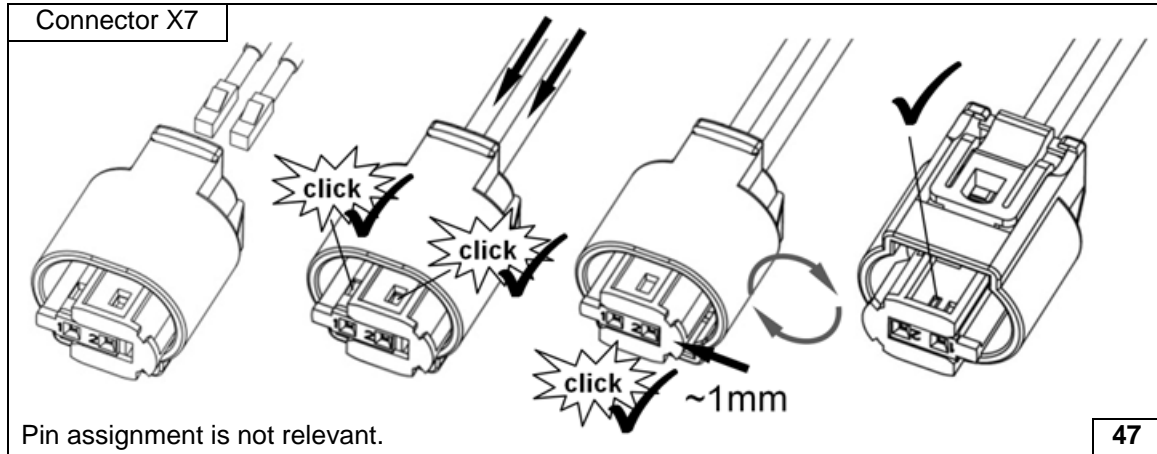
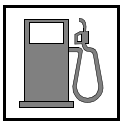

Completing metering pump connector

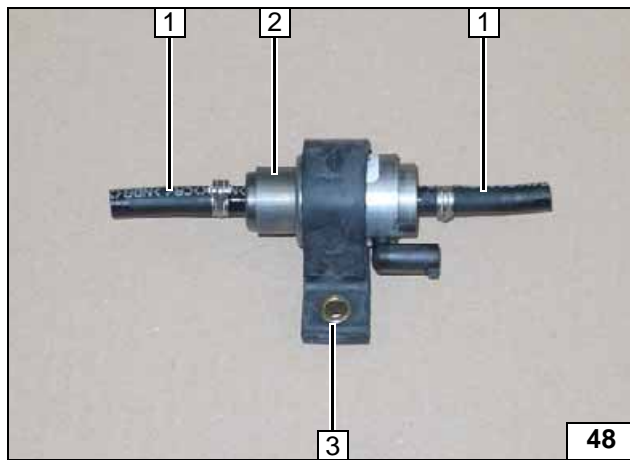

- 1 Hose section, 10mm dia. clamp
- 2 Metering pump
- 3 Metering pump mount

Premounting metering pump

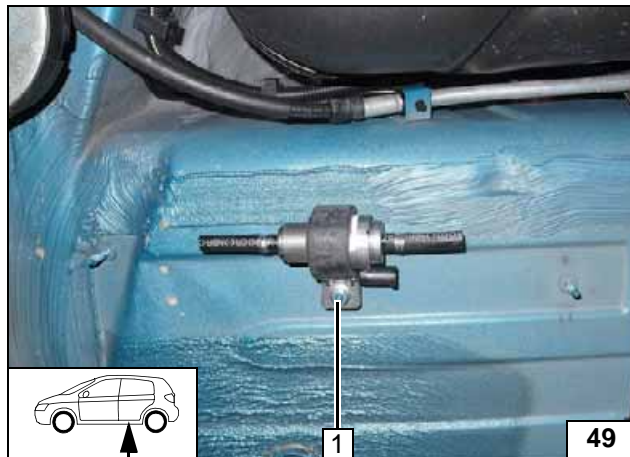

- 1 Original vehicle stud bolt, flanged nut



Installing metering pump

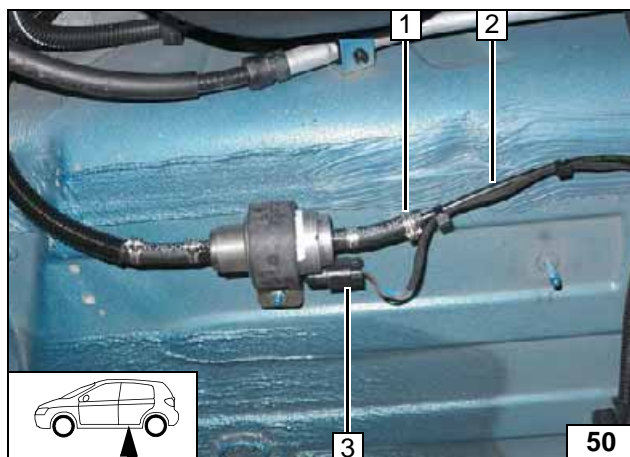

- 1 10 mm dia. clamp [2x]
- 2 Fuel line
- 3 Connector of metering pump wiring harness

Connecting metering pump

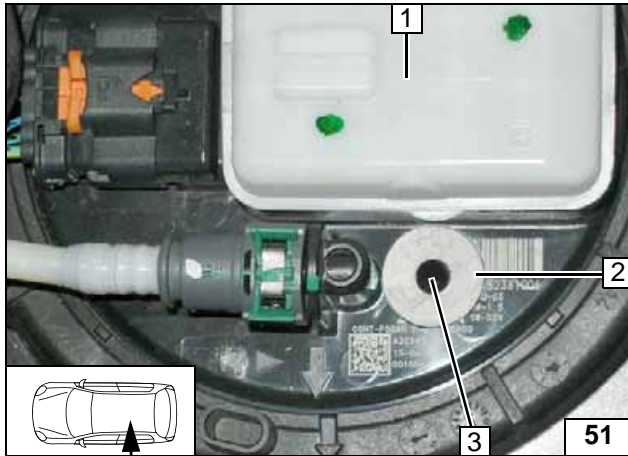
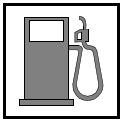

Installing FuelFix

Work steps F1 and F2.

- 1 Fuel tank sending unit
- 2 Position washer with outer dia. $d_a = 21.6\text{mm}$, will be used as a template
- 3 Hole pattern



Copying hole pattern

Work step F3.

- 1 Hole made with provided drill

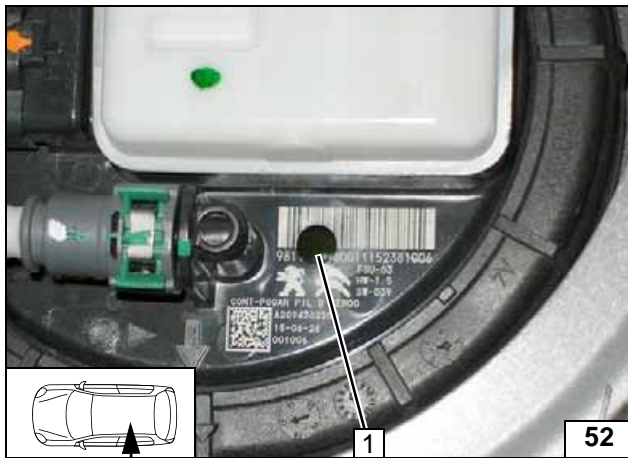

Hole for FuelFix

Work steps F4 and F5.

Bend FuelFix 1 according to template and cut to length. Insert into hole 2.

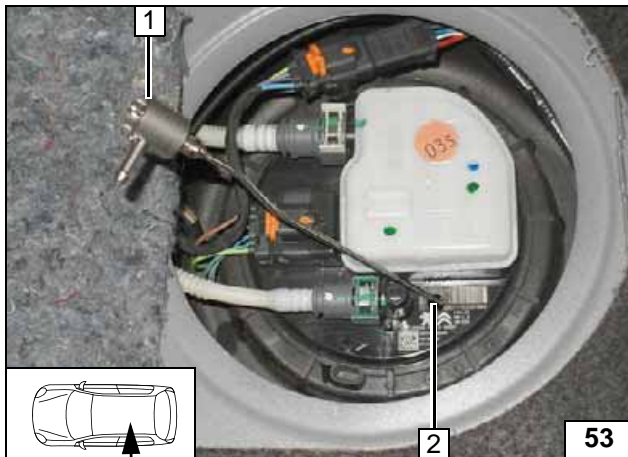

Inserting FuelFix

Work step F5.

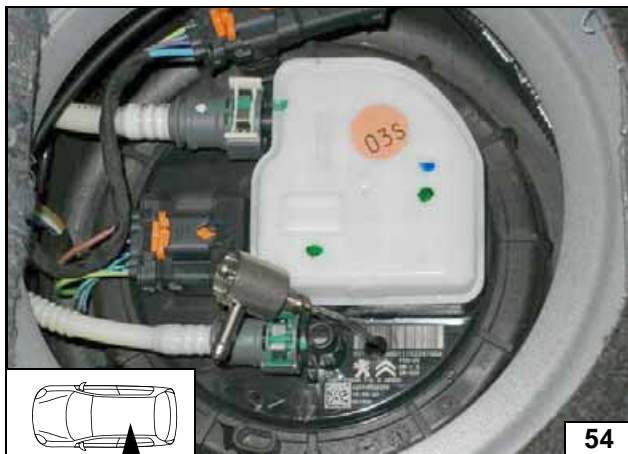

Inserting FuelFix

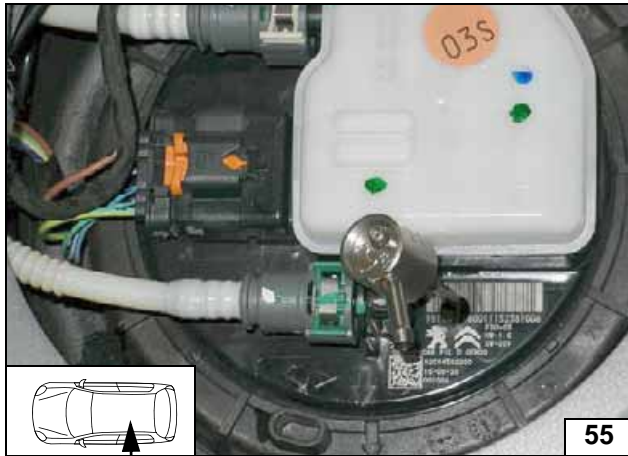
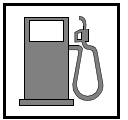

Inserting FuelFix



Inserting FuelFix

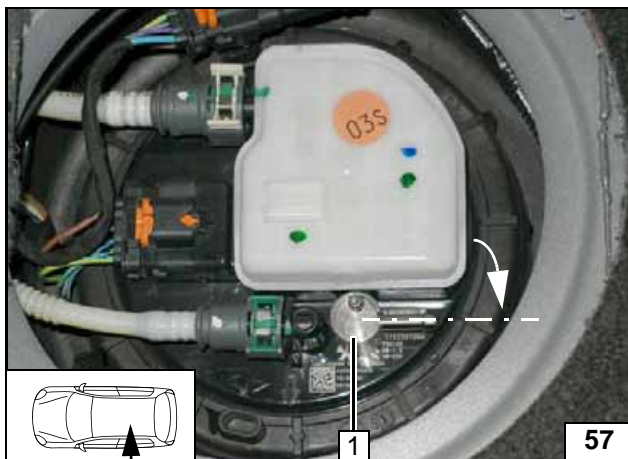

Work steps F5.3 and F5.4.

Align FuelFix 1 as shown.



Aligning FuelFix



Work step F6.

- 1 Fuel line
- 2 90° moulded hose, 10mm dia. clamp [2x]

Connecting fuel line

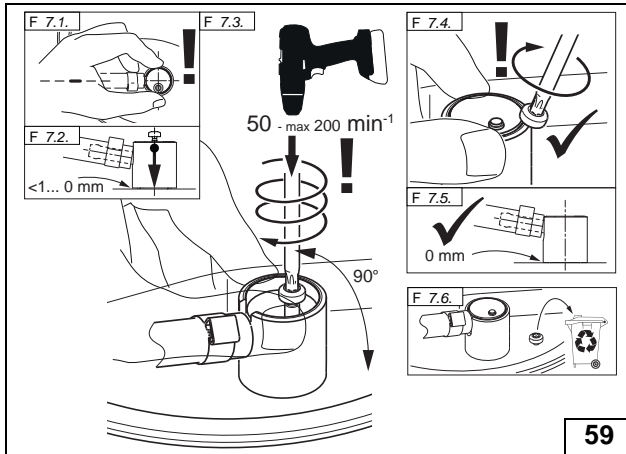
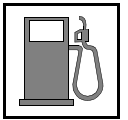

Work step F7.



Installing FuelFix



Work step F8.

Ensuring firm seating of FuelFix

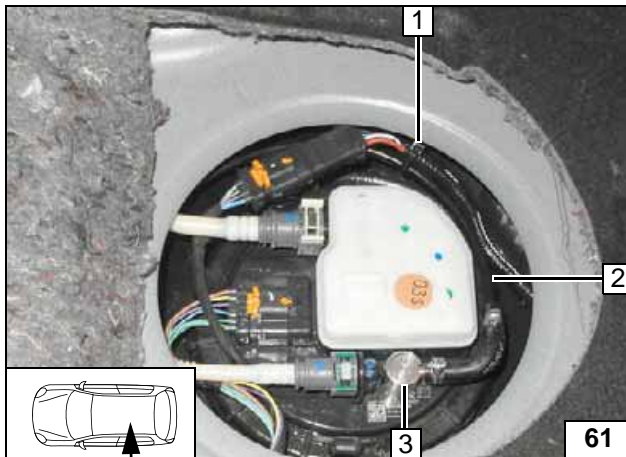

- 1 Cable tie as tension relief
- 2 Fuel line of FuelFix
- 3 FuelFix installed

Securing fuel line

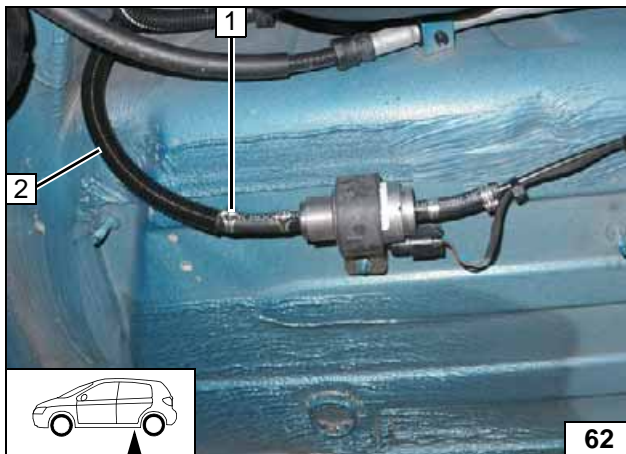

Ensure sufficient distance from neighbouring components, correct if necessary.

- 1 10 mm dia. clamp
- 2 Fuel line of FuelFix in corrugated tube



Connecting metering pump

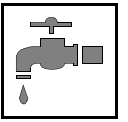

Coolant Circuit



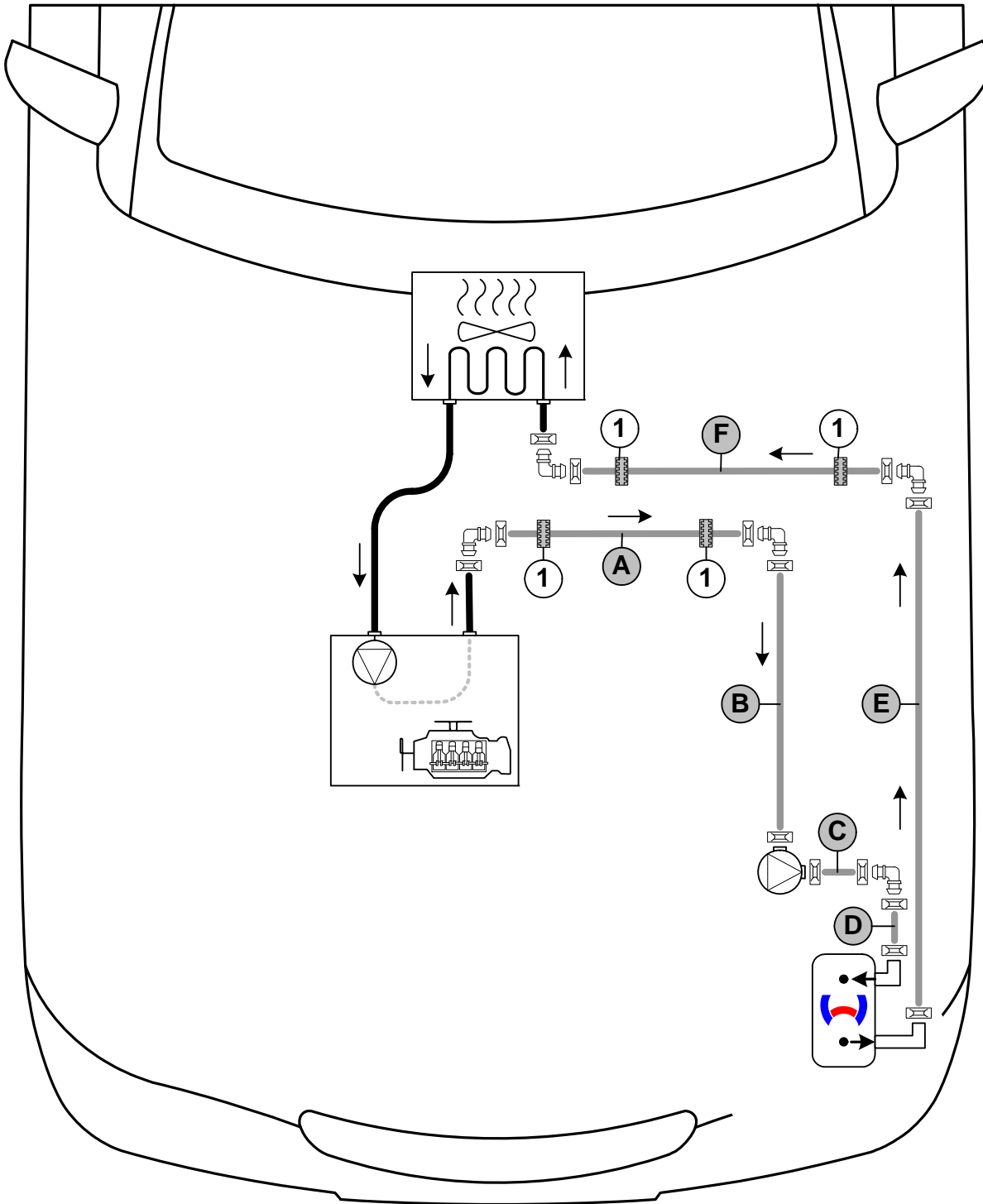

Any coolant running off should be collected in an appropriate container. Route hoses kink-free. Unless specified otherwise, always fasten using cable ties. Position clamps so that other hoses cannot be damaged. The heater must be filled with coolant when installing the hoses.

The connection should be modelled on an 'inline' circuit and based on the following diagram:



Hose routing diagram

All spring clips without a specific designation  = 25 mm dia. 1 = Black (sw) rubber isolator .
All connecting pipes  = 18x18 mm dia.



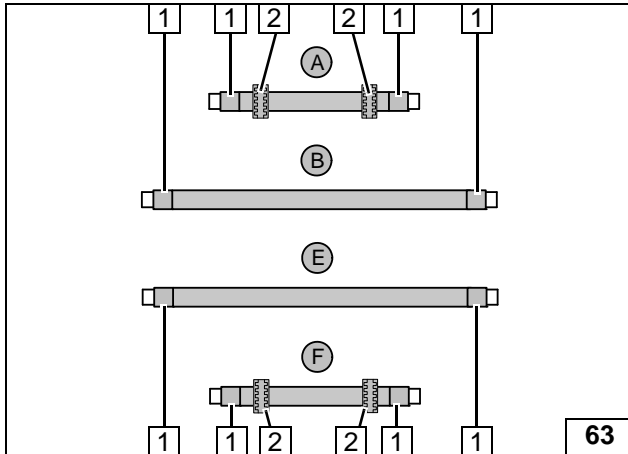

Slide on braided protection hoses and cut to length.



- 1 Cut heat shrink plastic tubing to size, 50mm long [8x]
- 2 Black (sw) rubber isolator [4x]

Installing braided protection hoses

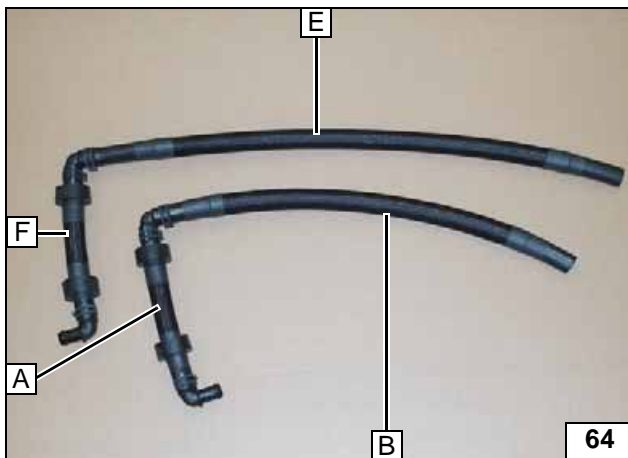

Premounting hoses

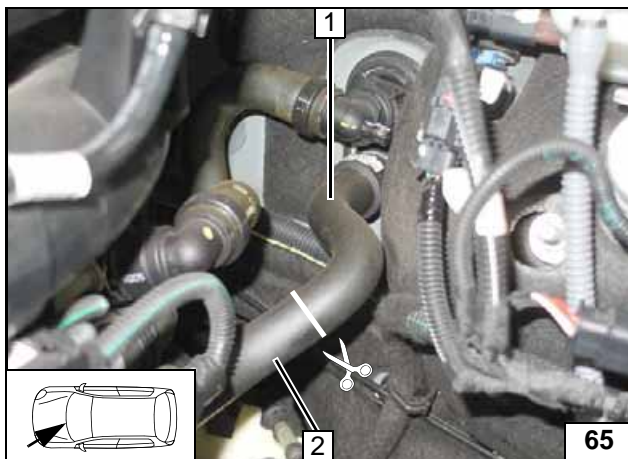

Cut hose of engine outlet/heat exchanger inlet 1 at the marking.



- 1 Heat exchanger inlet hose section
- 2 Engine outlet hose section

Cutting point

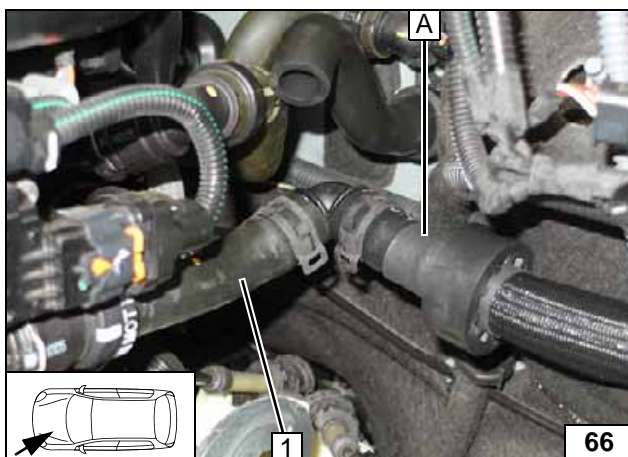

- 1 Engine outlet hose section

Connecting engine outlet

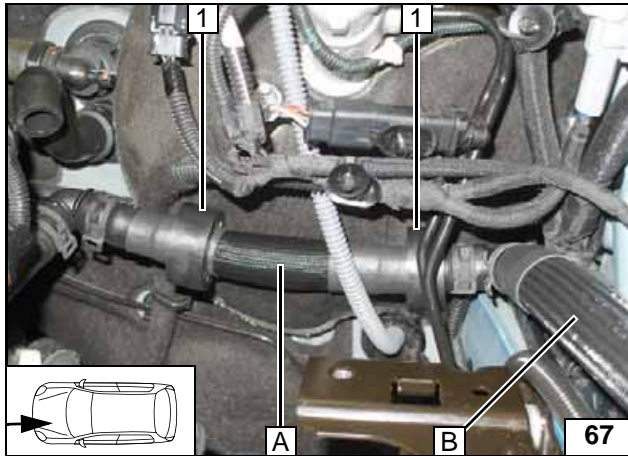

1 Position black (sw) rubber isolator [2x]

Routing in engine compartment

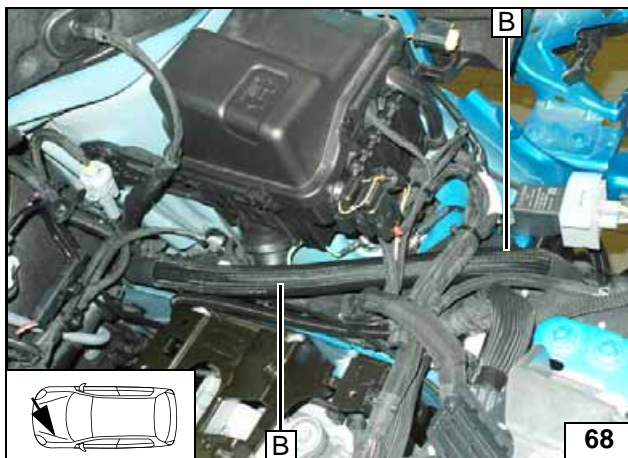

Routing in engine compartment

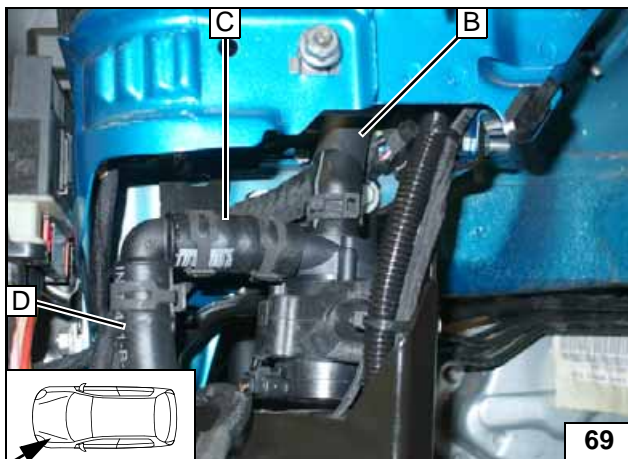

Connecting circulating pump

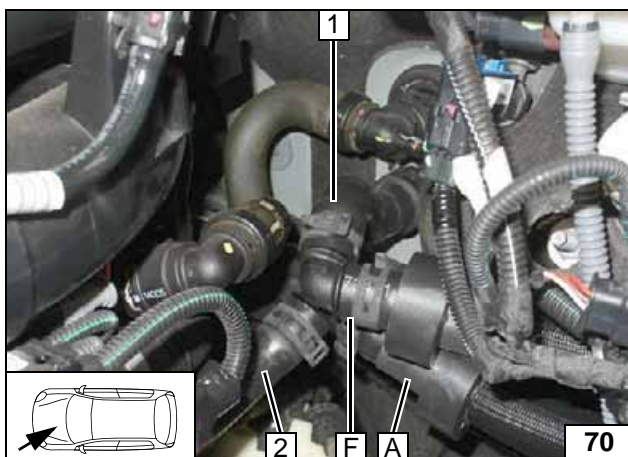

Align hoses. Ensure sufficient distance from neighbouring components, correct if necessary.

- 1 Hose of heat exchanger inlet
- 2 Hose of engine outlet



Connecting heat exchanger inlet

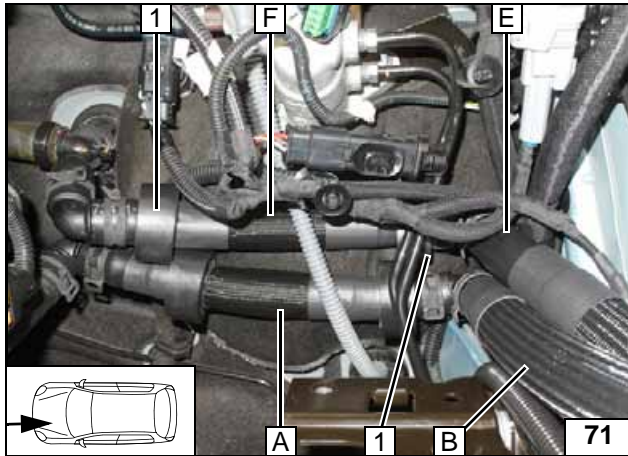
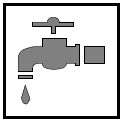

1 Position black (sw) rubber isolator [2x]

Routing in engine compartment

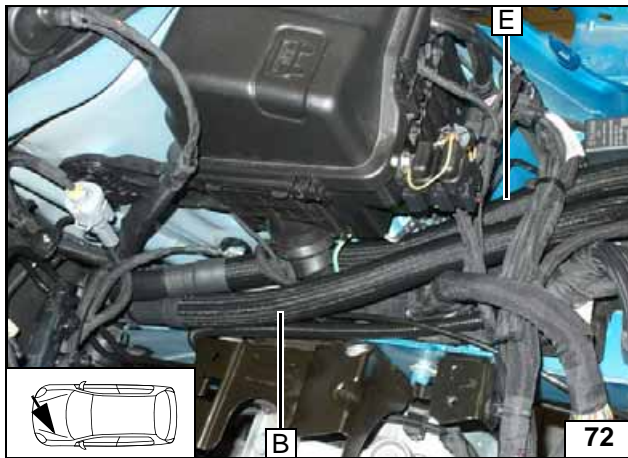

Routing in engine compartment

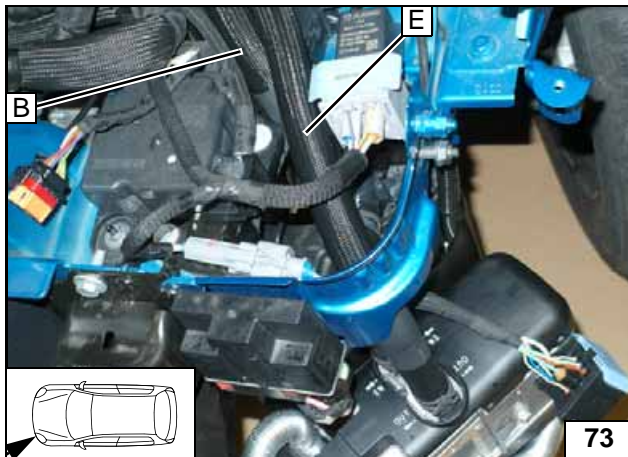

Connect-
ing heater

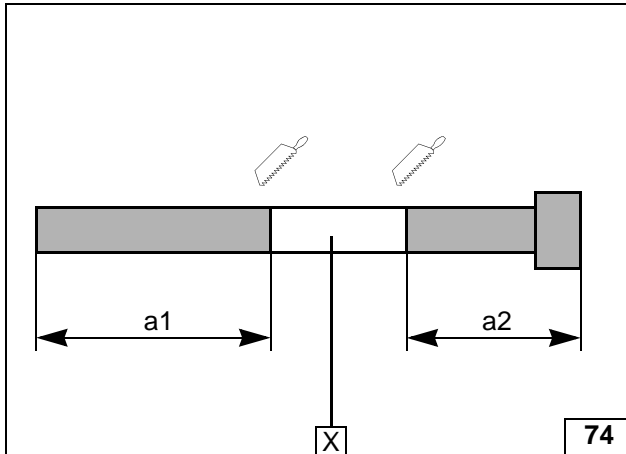
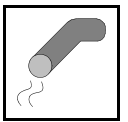

Exhaust Gas

a1 = 300
a2 = 300

X=



Preparing exhaust pipe

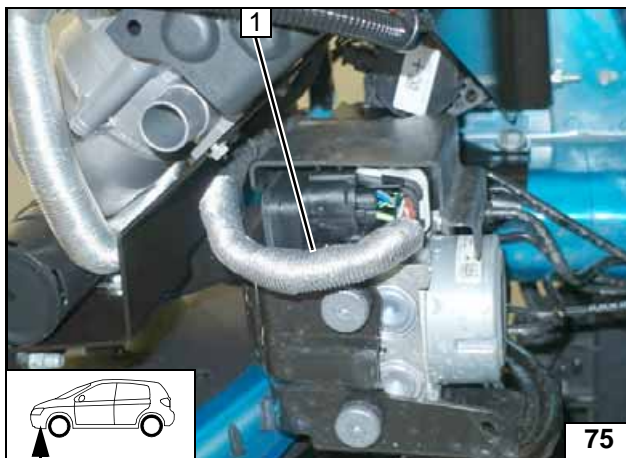

Cut heat protection hose 1 lengthways, install onto original vehicle wiring harness and align.



Mounting heat protection hose

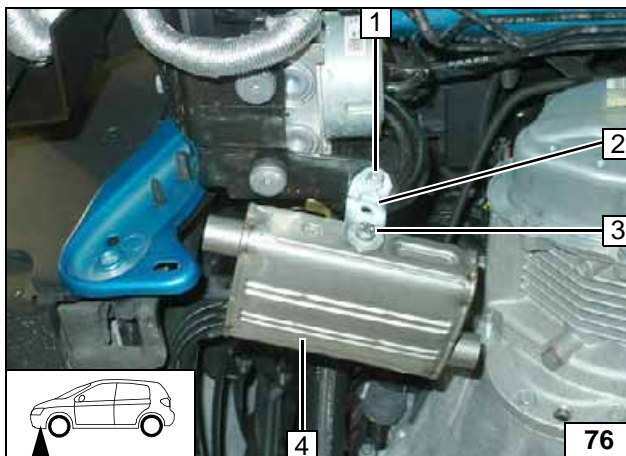

- 1 M6x20 bolt, original vehicle hole, flanged nut
- 2 Angle bracket
- 3 M6x16 bolt, spring lockwasher, large diameter washer
- 4 Exhaust silencer

Installing silencer

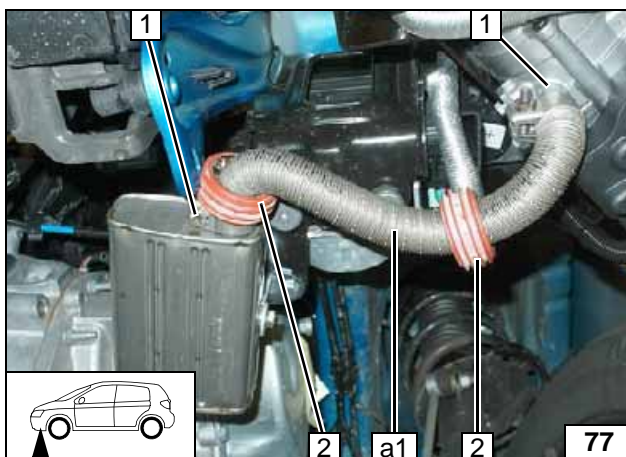

- 1 Hose clamp [2x]
- 2 Spacer bracket [2x]

Installing exhaust pipe a1

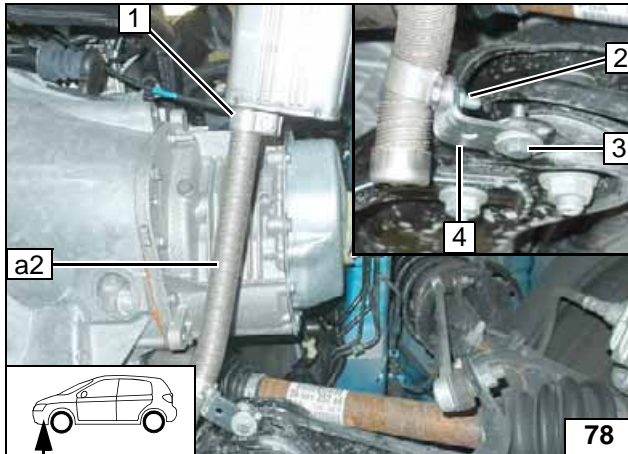
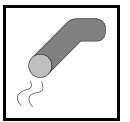

- 1 Hose clamp
- 2 M6x20 bolt, p-clamp, flanged nut
- 3 M6x20 bolt, large diameter washer [2x], flanged nut, existing hole
- 4 Angle bracket

Installing exhaust pipe a2

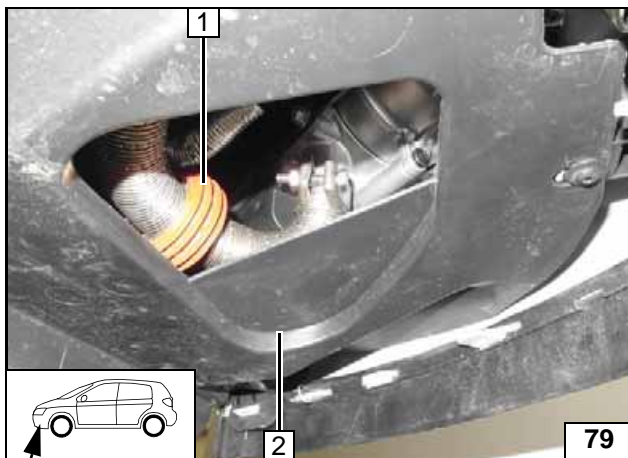

Install wheel well trim 2. Align spacer bracket 1 with wheel well trim 2.



Aligning exhaust pipe a1

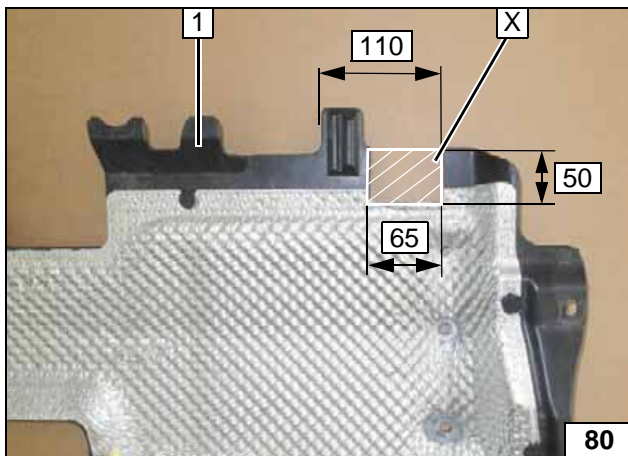

Cut out underide protection 1 at the marking.

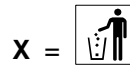

Cutting out underide protection

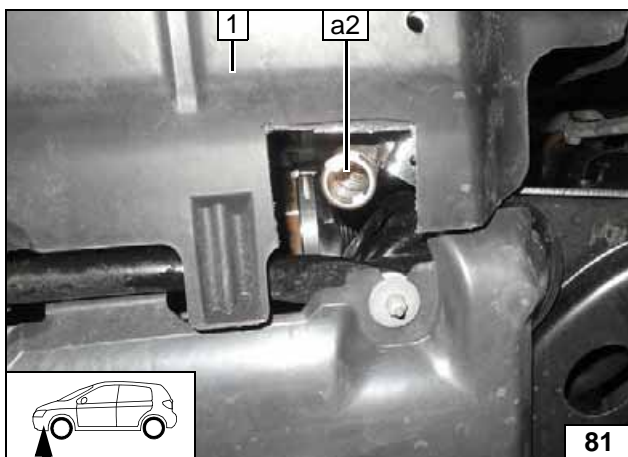

Install underide protection 1. Align exhaust pipe a2 with the centre of the cut-out and flush with underide protection 1. Ensure sufficient distance from neighbouring components, correct if necessary.



Aligning exhaust pipe a2

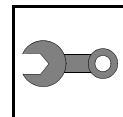

Final Work



Reassemble the components in reverse order. Check all hoses, clamps and all electrical connections for firm seating. Insulate and tie back loose lines. Only use manufacturer-approved coolant. Spray the heater components with anti-corrosion wax (Tectyl 100K).

- **Connect the battery.**
- **Fill and bleed the coolant circuit according to the vehicle manufacturer's instructions.**
- **Program MultiControl CAR, teach Telearstart transmitter.**
- **For initial startup and function check, please see installation instructions.**
- **Make settings on A/C control panel according to the 'Operating Instructions'.**
- **Place the 'Switch off parking heater before refuelling' caution label near the filler neck.**

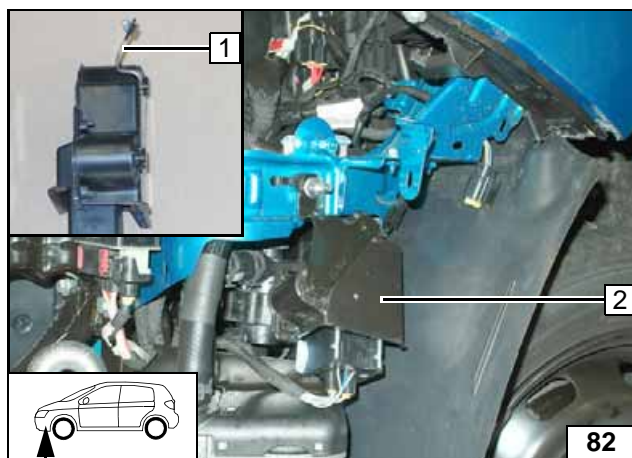

C3

Bend tab 1 as shown.
Install control unit 2.



Installing control unit

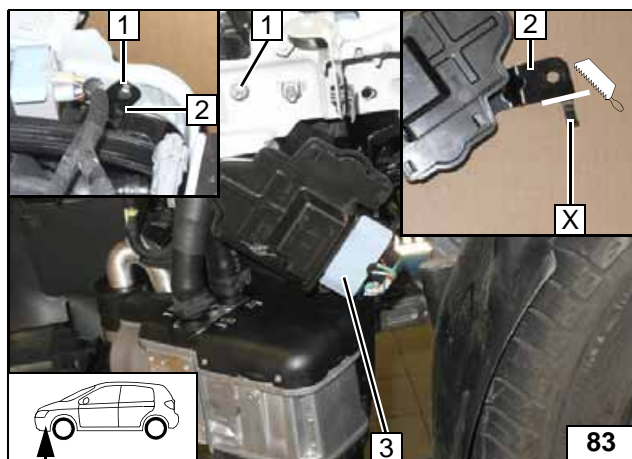

DS3

Cut tab of control unit bracket 2 as shown.
Install control unit 3 with bracket.

1 M6x20 bolt, flanged nut

X =



Installing control unit

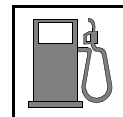

FuelFix Template

Top view

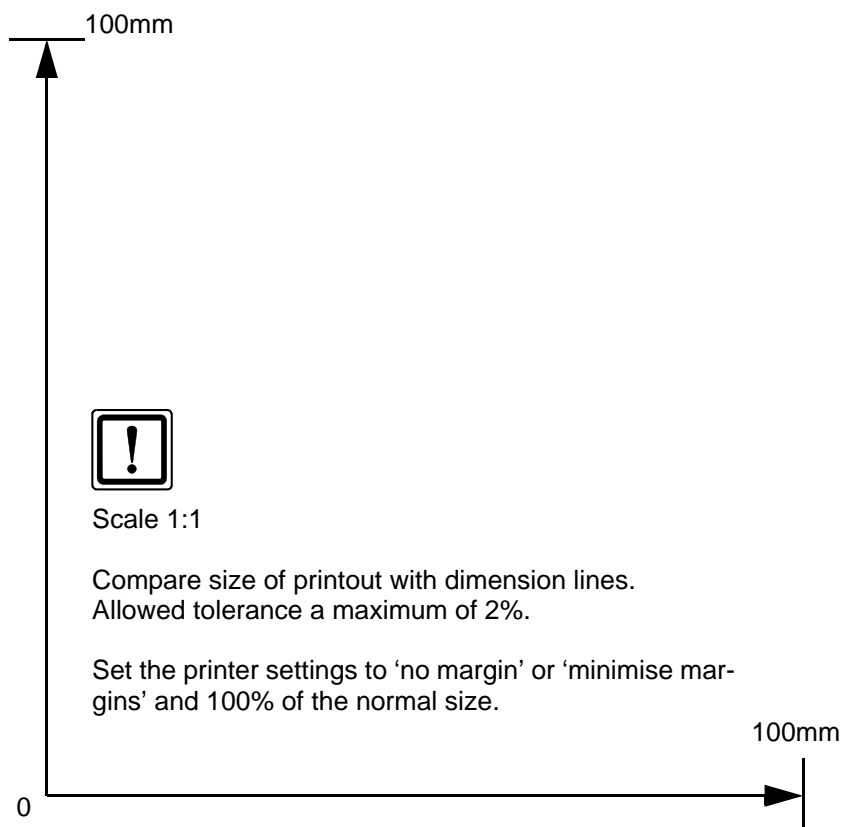
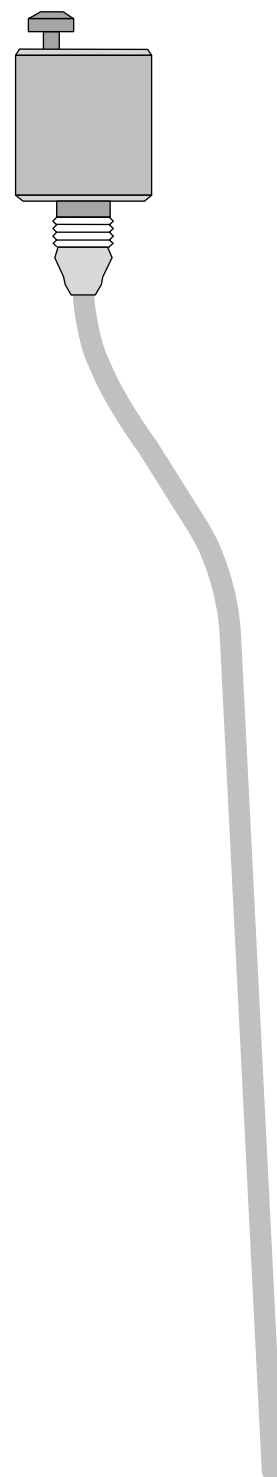
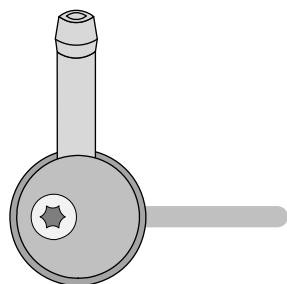

Operating Instructions for Automatic A/C

Please remove page and add to the vehicle operating instructions.

Note:

We recommend matching the heating time to the driving time.

Heating time = driving time

Example:

For a driving time of approx. 20 min. (in one direction), we recommend not exceeding a switch-on time of 20 min.

Passenger compartment monitoring, if installed, must be deactivated in addition to the vehicle settings for the heating operation.

For instructions on deactivation, please refer to the operating instructions of the vehicle.

Before parking the vehicle, make the following settings:

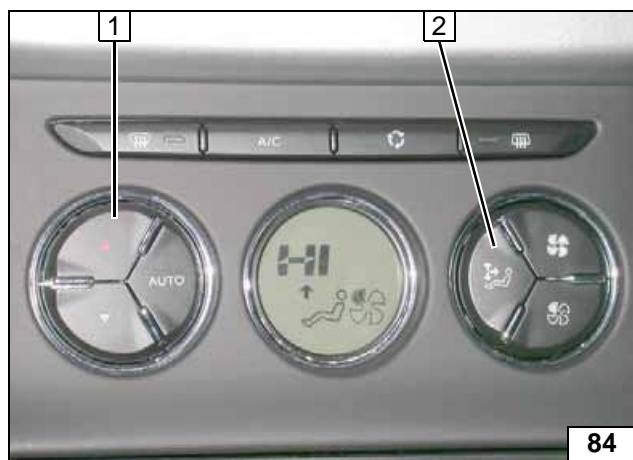

- 1 Set temperature to 'HI'
- 2 Air outlet faces upward



A/C control panel

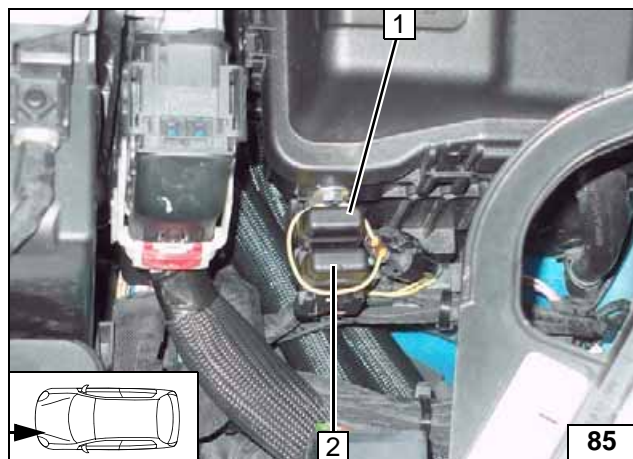

- 1 30A passenger compartment main fuse F2
- 2 20A heater fuse F1

Engine compartment fuses

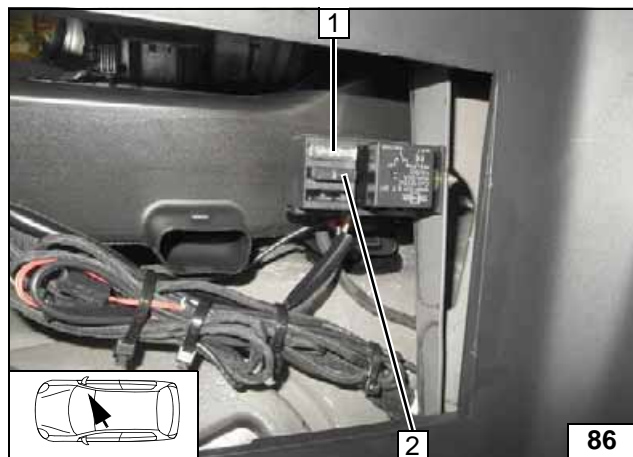

- 1 25A fan fuse F4
- 2 1A heater control fuse F3

Passenger compartment fuses

