

Water Heater

Thermo Top Evo Parking Heater



Installation Documentation Citroen C4 Aircross

Validity

Manufacturer	Model	Type	EG-BE No./ABE
Citroen C4	Aircross	AF	e2 * 2007 / 46 * 0117 * ...

Motorisation	Fuel	Transmission type	Output in kW	Displacement in cm ³	Engine code
1.6i	Petrol	5-gear SG	86	1590	4A92
2.0i	Petrol	5-gear SG	113	1998	4A93

SG = manual transmission

from model year 2012
Left-hand drive vehicle

Verified equipment variants:

- Manual / automatic air-conditioning system
- Fog light
- Xenon / Headlight washer system
- Start-Stop
- 2 WD

Not verified:

- Automatic transmission
- Passenger compartment monitoring
- 4 WD

Total installation time: approx. 8 hours

Citroen C4 Aircross

Table of Contents

Validity	1	Combustion Air	16
Installation Overview	2	Preparing Coolant Circuit	17
Information on Total Installation Time	2	1.6 B Coolant Circuit	18
Information on Operating and Installation Instructions	3	2.0 B Coolant Circuit	23
Information on Validity	4	Exhaust Gas	27
Technical Information	4	Fuel	29
Explanatory Notes on Document	4	Underride Protection	33
Preliminary Work	5	Final Work	34
Heater Installation Location	5	Template for Fuel Standpipe	35
Electrical System	8	Operating Instructions for Manual Air-Conditioning	36
Fan Control	9	Operating Instructions Automatic Air-Conditioning	37
Digital Timer	12		
Remote Option (Telestart)	12		
Preparing Installation Location	13		
Preparing Heater	14		
Installing Heater	15		

Necessary Components

- Basic delivery scope *Thermo Top Evo* in accordance with price list
- Installation kit for Citroen C4 Aircross 2012 Petrol: **1318690A**
- Heater control in accordance with price list and upon consultation with end customer
- In case of Telestart, indicator lamp in accordance with price list and in consultation with end customer

Installation Overview

Legend:

1. Heater
2. Fuse holder of engine compartment
3. Fuse holder of passenger compartment
4. Circulating pump
5. Digital timer
6. Metering pump

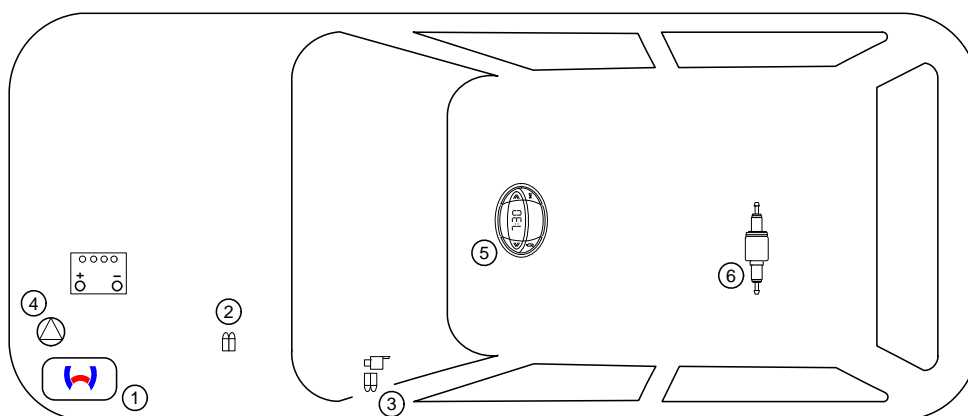

Information on Total Installation Time

The total installation time includes the time needed for mounting and demounting of the vehicle-specific components, the heater specific installation time and all other times required for the system integration and initial start-up of the heater.

The total installation time may vary for vehicle equipment other than provided.

Information on Operating and Installation Instructions

1 Important Information (not complete)

1.1 Installation and Repair



The improper installation or repair of Webasto heating and cooling systems can cause fire or the leakage of deadly carbon monoxide, leading to serious injury or death.



To install and repair Webasto heating and cooling systems you need to have completed a special company training course and have the appropriate technical documentation, special tools and special equipment.



Installation and repair may ONLY be carried out by persons trained and certified in a Webasto training course. NEVER try to install or repair Webasto heating or cooling systems if you have not completed a Webasto training course, you do not have the necessary technical skills and you do not have the technical documentation, tools and equipment available to ensure that you can complete the installation and repair work properly.

Only use genuine Webasto parts. See the Webasto air and water heaters accessories catalogue for this purpose.

1.2 Operation

To ensure safe operation, we recommend having the heater checked every two years by an authorised Webasto dealer, especially when used over a long period and/or under extreme environmental conditions.

Do not operate the heater in closed rooms due to the danger of poisoning and suffocation.

Always switch off the heater before refuelling.

The heater may only be used with the prescribed fuel Diesel (DIN EN 590) or petrol (DIN EN 227).

The heater may not be cleaned with a high-pressure cleaner.

1.3 Please note

ALWAYS follow all Webasto installation and operating instructions and observe all warnings.

To become familiar with and understand all functions and properties of the heater, the operating instructions must be read carefully and observed at all times.

For proper, safe installation and repair work, the installation instructions with all warnings and safety information must be carefully read and observed at all times. Please always contact a workshop authorised by Webasto for all installation and repair work.

IMPORTANT

Webasto shall assume no liability for defects, damage and injuries resulting from a failure to observe the installation, repair and operating instructions of the information contained in them.

This liability exclusion particularly applies to improper installations and repairs, installations and repairs by untrained persons or in the case of a failure to use genuine spare parts.

The liability due to culpable disregard to life, limb or health and due to damage or injuries caused by a wilful or reckless breach of duty remain unaffected, as does the obligatory product liability.

Installation should be carried out according to the general, standard rules of technology. Unless specified otherwise, fasten hoses, lines and wiring harnesses to original vehicle lines and wiring harnesses using cable ties. Insulate loose wire ends and tie back.

Sharp edges should be fitted with rub protection (split-open fuel hose)! Spray unfinished body areas, e.g. drilled holes, with anti-corrosion wax (Tectyl 100K, Order No. 111329).

Observe the instructions and guidelines of the respective vehicle manufacturer for demounting and mounting vehicle specific components!

The initial startup is to be executed with the Webasto Thermo Test Diagnosis.

When installing an IPCU, the corresponding settings must be checked or adjusted before the installation.

2 Statutory regulations governing installation

Guidelines	Thermo Top Evo
Heating Directive ECE R122	E1 00 0258
EMC Directive ECE R10	E1 03 5627

NOTE

The regulations of these guidelines are binding in the scope of the Directive 70/156/EEC and/or 2007/46/EC (for new vehicle models from 29/04/2009) and should also be observed in countries in which there are no special regulations.

IMPORTANT

Failure to follow the installation instructions will result in the invalidation of the type approval for the heater and therefore invalidation of the general **homologation of the vehicle**.

NOTE

For vehicles with an EU permit, no entry in accordance with § 19 Sub-Section 4 of Annex VIII b to the Road Traffic Act is required.

2.1 Excerpt from the directive 2001/56/EC Appendix VII for the installation of the heater

Beginning of excerpt.

ANNEX VII

REQUIREMENTS FOR COMBUSTION HEATERS AND THEIR INSTALLATION

1. GENERAL REQUIREMENTS

1.7.1. A clearly visible tell-tale in the operator's field of view shall inform when the combustion heater is switched on or off.

2. VEHICLE INSTALLATION REQUIREMENTS

2.1. Scope

2.1.1. Subject to paragraph 2.1.2. combustion heaters shall be installed according to the requirements of this Annex.

2.1.2. Vehicles of category O having liquid fuel heaters are deemed to comply with the requirements of this Annex.

2.2. Positioning of heater

2.2.1. Body sections and any other components in the vicinity of the heater must be protected from excessive heat and the possibility of fuel or oil contamination.

2.2.2. The combustion heater shall not constitute a risk of fire, even in the case of overheating. This requirement shall be deemed to be fulfilled if the installation ensures an adequate distance to all parts and suitable ventilation, by the use of fire resistant materials or by the use of heat shields.

2.2.3. In the case of M2 and M3 vehicles, the heater must not be positioned in the passenger compartment. However, an installation in an effectively sealed envelope which also complies with the conditions in paragraph 2.2.2 may be used.

2.2.4. The label referred to in paragraph 1.4 or a duplicate, must be positioned so that it can be easily read when the heater is installed in the vehicle.

2.2.5. Every reasonable precaution should be taken in positioning the heater to minimise the risk of injury and damage to personal property.

2.3. Fuel supply

2.3.1. The fuel filler must not be situated in the passenger compartment and must be provided with an effective cap to prevent fuel spillage.

2.3.2. In the case of liquid fuel heaters, where a supply separate to that of the vehicle is provided, the type of fuel and its filler point must be clearly labelled.

2.3.3. A notice, indicating that the heater must be shut down before refuelling, must be affixed to the fuelling point. In addition a suitable instruction must be included in the manufacturer's operating manual.

2.4. Exhaust system

2.4.1. The exhaust outlet must be located so as to prevent emissions from entering the vehicle through ventilators, heated air inlets or opening windows.

2.5. Combustion air inlet

2.5.1. The air for the combustion chamber of the heater must not be drawn from the passenger compartment of the vehicle.

2.5.2. The air inlet must be so positioned or guarded that blocking by rubbish or luggage is unlikely.

2.6. Heating air inlet

2.6.1. The heating air supply may be fresh or recirculated air and must be drawn from a clean area not likely to be contaminated by exhaust fumes emitted either by the propulsion engine, the combustion heater or any other vehicle source.

2.6.2. The inlet duct must be protected by mesh or other suitable means.

2.7. Heating air outlet

2.7.1. Any ducting used to route the hot air through the vehicle must be so positioned or protected that no injury or damage could be caused if it were to be touched.

2.7.2. The air outlet must be so positioned or guarded that blocking by rubbish or luggage is unlikely.

End of excerpt.

In multilingual versions the German language is binding.

Citroen C4 Aircross

Information on Validity

This installation documentation applies to Citroen C4 Aircross Petrol vehicles - for validity, see page 2 - from model year 2012 and later, assuming technical modifications to the vehicle do not affect installation, any liability claims excluded. Depending on the vehicle version and equipment, modifications may be necessary during installation with respect to this installation documentation.

Vehicle and engine types, equipment variants and other specifications not listed in this installation documentation have not been tested. However, installation according to this installation documentation may be possible.

Technical Information

Special tools

- Hose clamp pliers for auto-tightening hose clamps
- Hose clamp pliers for Clic hose clamps of type W
- Automatic wire stripper 0.2 - 6mm²
- Crimping pliers for cable lug / tab connector 0.5 - 6mm²
- Torque wrench for 2.0 - 10 Nm
- Hose clamping pliers
- Metric thread-setter kit
- Webasto Thermo Test Diagnosis with current software

Dimensions

- All dimensions in mm

Tightening torque values

- Tightening torque values of 5x13 heater bolts = 8Nm
- Tightening torque values of 5x15 retaining plate of water connection piece bolts = 7Nm
- Tighten other bolt connections in accordance with manufacturer's instructions or in accordance with state-of-the-art-technology.

Explanatory Notes on Document

You will find an identification mark on the outside top right corner of the page in question to provide you with a quick overview of the individual working steps.

Special features are highlighted using the following symbols:

Mechanical system

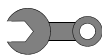

Electrical system



Coolant circuit



Combustion air



Fuel



Exhaust gas



Software



Specific risk of injury or fatal accidents



Specific risk of damage to components



Specific risk of fire or explosion.



Reference to general installation instructions of the Webasto components or to the manufacturer's vehicle-specific documents.



Reference to a special technical feature



The arrow in the vehicle icon indicates the position on the vehicle and the viewing angle

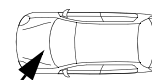
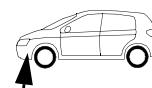

Citroen C4 Aircross

Preliminary Work

Vehicle

- Open the fuel tank cap.
- Ventilate the fuel tank.
- Close the fuel tank cap again.
- Depressurise the cooling system.
- Disconnect and completely remove the battery with carrier.
- Remove the left front wheel.
- Remove the left-hand wheel well trim.
- Remove the front underride protection.
- Remove the underride protection to the left of the fuel line.
- Remove the air filter together with the intake hose.
- Remove the side trim of the A-pillar on the driver's side.
- Remove the footwell trim on the front passenger's side.
- Remove the rear bench seat.
- Open the right-hand tank-fitting service lid.
- Remove the fuel-tank sending unit in accordance with the manufacturer's instructions.

Heater

- Remove years that do not apply from the type and duplicate label.
- Attach the duplicate label (type label) in the appropriate place in the engine compartment.

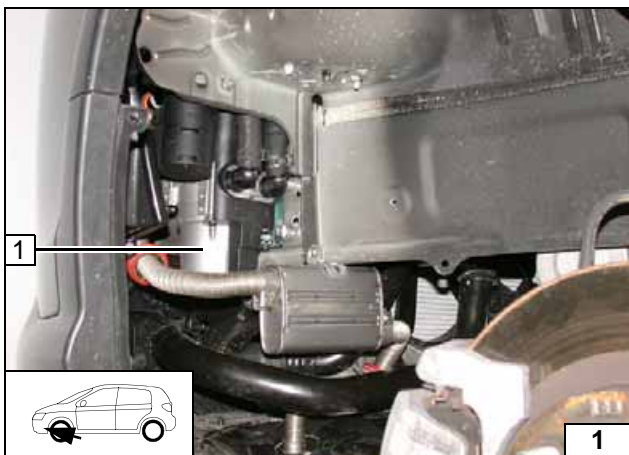

Heater Installation Location

1 Heater

Installation
location

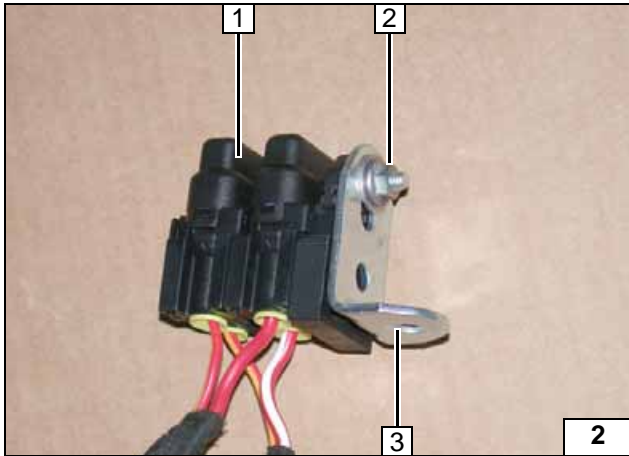

Fuse holder of engine compartment

- 1 F1-2 fuses
- 2 M5x16 bolt, large diameter washer [2x], retaining plate, fuse holder, nut
- 3 Angle bracket



Premounting fuse holder of engine compartment

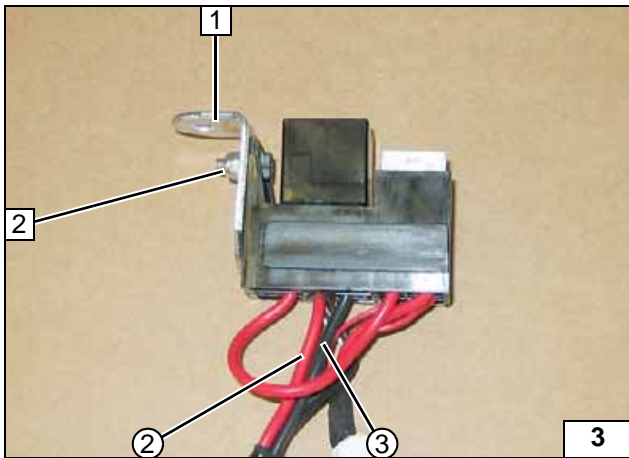

Fuse holder of passenger compartment

- 1 Angle bracket
- 2 M5x12 bolt, large diameter washer [2x], nut
- ② Red (rt) wire of K1/87a
- ③ Black (sw) wire of K1/30

Premounting fuse holder of passenger compartment

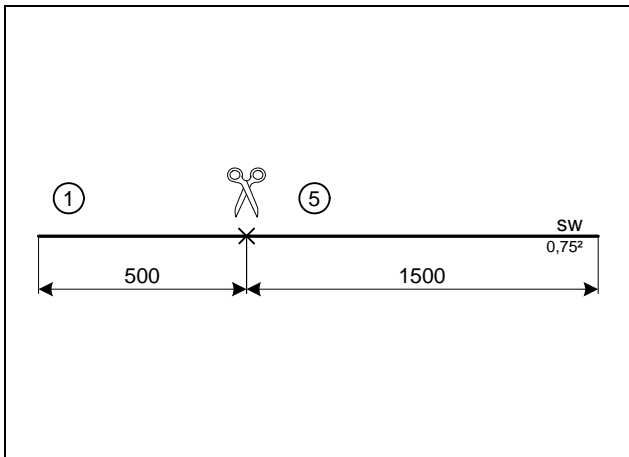

Cutting wires to length

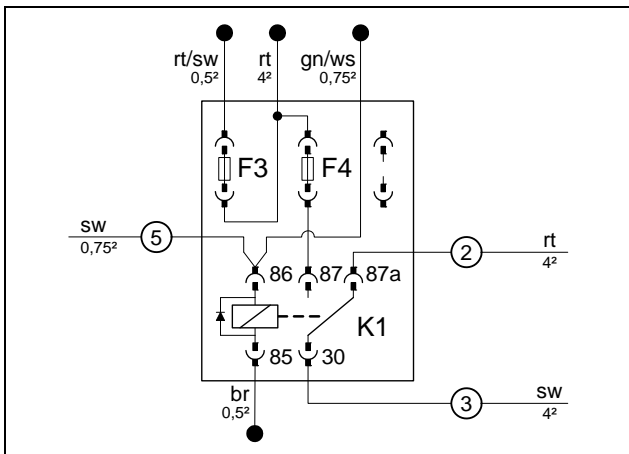

Also connect additional black (sw) 0,75² wire ⑤ to K1/86 and pull into protective sleeving. Insert 25A fuse F4 and K1 relay.



Preparing fuse holder of passenger compartment

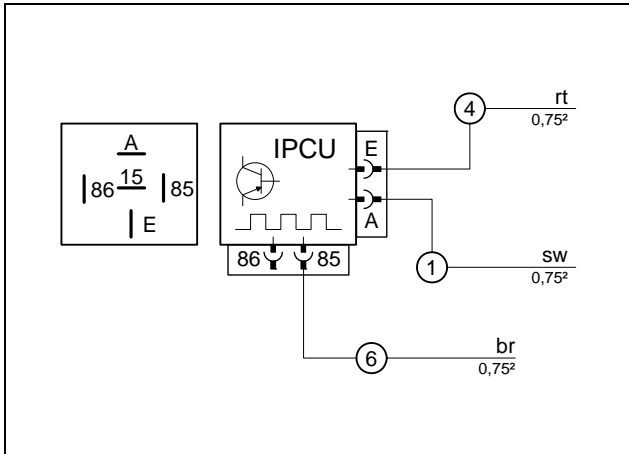
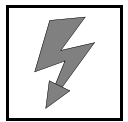

The preprogrammed data of the IPCU is based on averages that can deviate in some cases. This circumstance is design-related due to the fan module of the vehicle. In case of too high / too low fan power, the IPCU can be reprogrammed using the Webasto diagnosis. Change voltage in steps of 0.1V. Measure current consumption on the blue wire of the fan motor. Stick to a value of < 6A.

- Duty-Cycle:** 100%
- Frequency:** 1kHz
- Voltage:** 4.2V
- Function:** High-side



Premounting IPCU, view on contact side

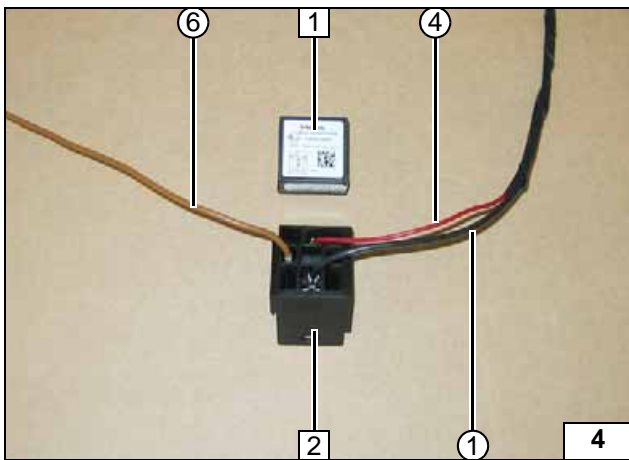

IPCU 1 will be attached after installation.

- 2** IPCU socket
- 1** Black (sw) wire of IPCU/A socket
- 4** Red (rt) wire of IPCU/E socket
- 6** Brown (br) wire of IPCU/85 socket



Premounting IPCU

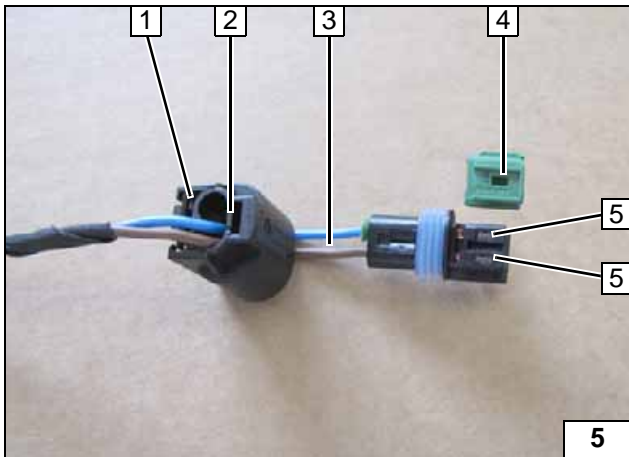

Complete connector of metering pump after routing. Pin assignment is not relevant.

- 1** Connector housing
- 2** Lock
- 3** Blue/brown (bl/br) wires
- 4** Coding
- 5** Timer lock



Dismantling connector



Electrical System

Earth wire

- 1 Brown (br) earth wire, 6mm dia. cable lug
- 2 Original vehicle earth point

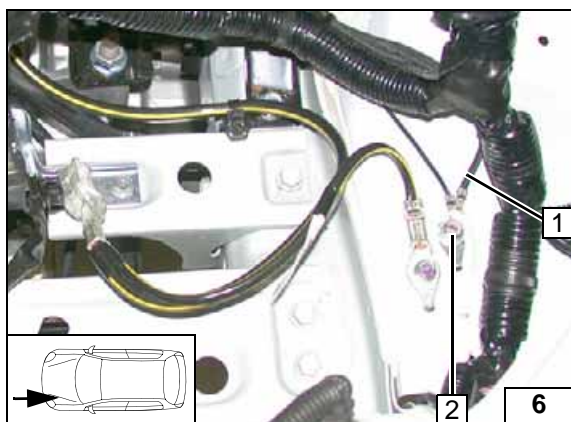

Positive wire

- 1 Red (rt) positive wire, 6mm dia. cable lug
- 2 Positive distributor of battery

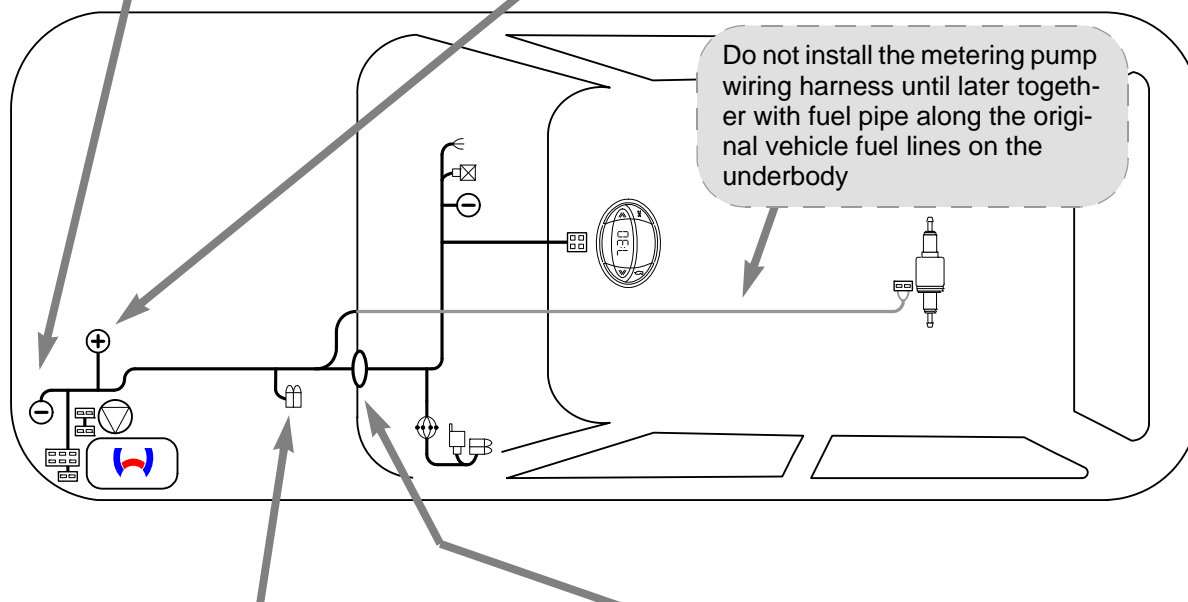
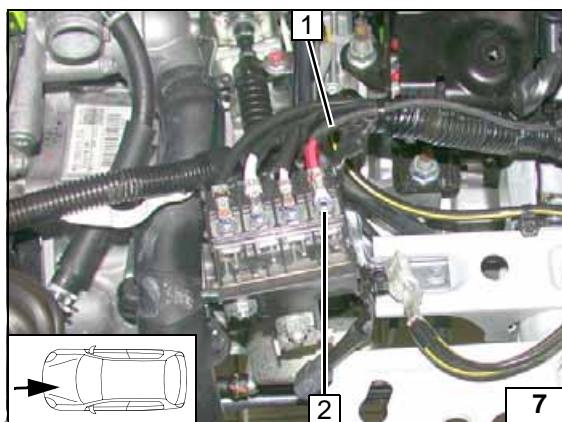

Wiring harness routing diagram

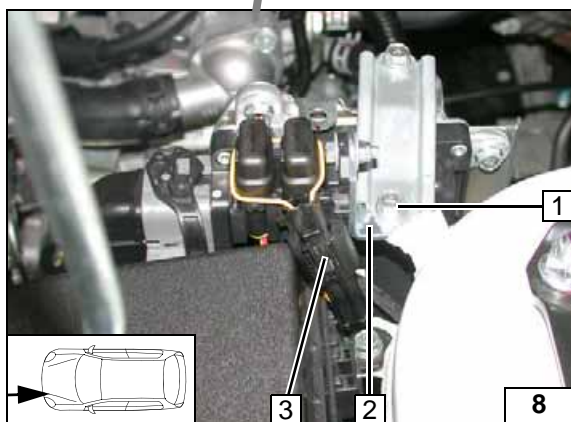

Fuse holder of engine compartment

- 1 Original vehicle bolt
- 2 Angle bracket
- 3 Diagnosis connection of heater

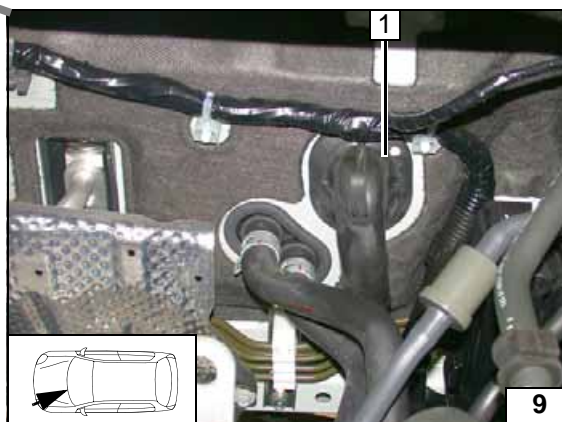

Wiring harness pass through

Route wiring harnesses of engine compartment fuse holder and heater control to the passenger compartment through original vehicle protective rubber plug 1.



Fan Control

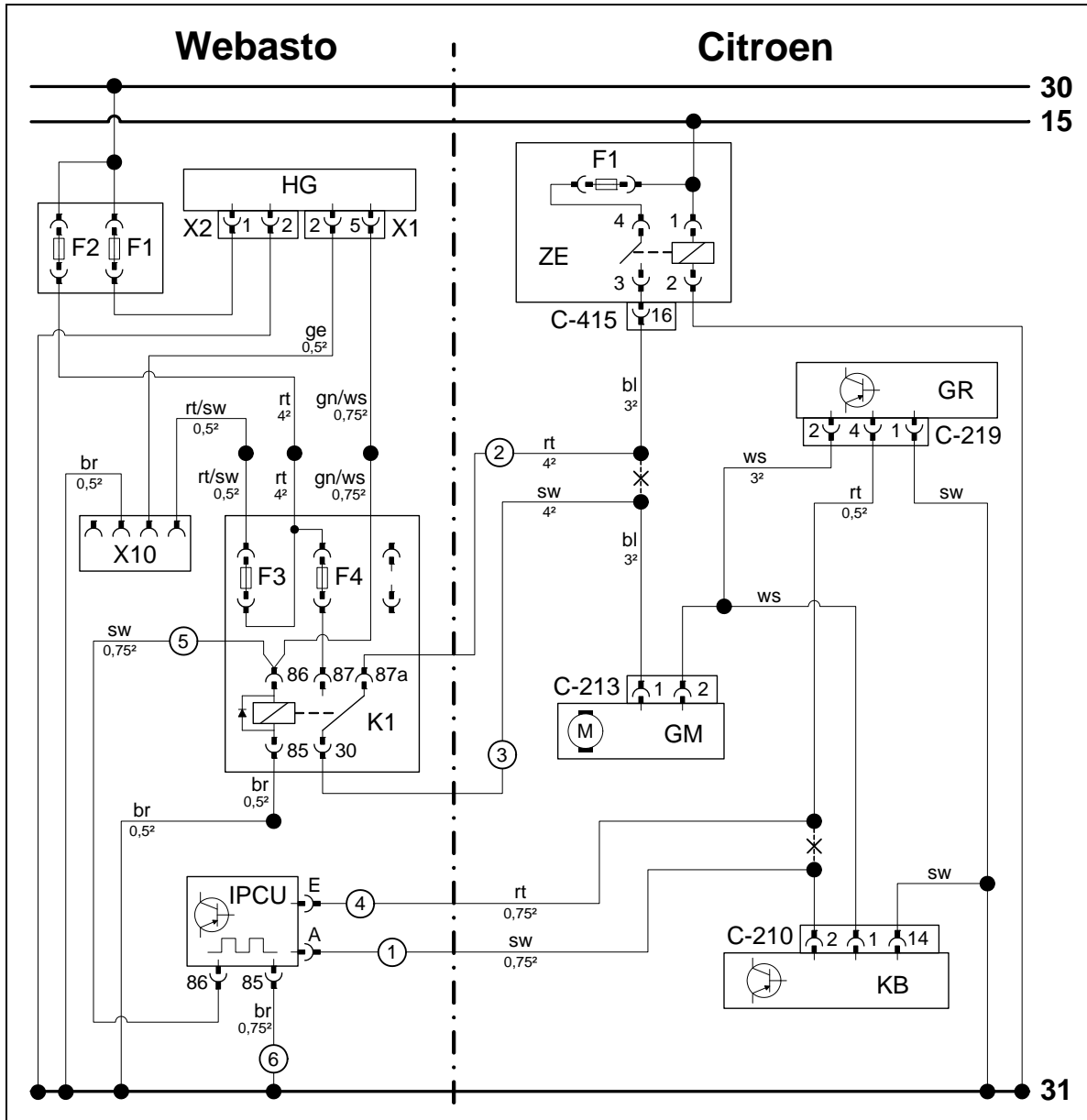

Wiring diagram

Webasto components		Vehicle components		Colours and symbols	
HG	TT-Evo heater	GM	Fan motor	rt	red
X1	6-pin heater connector	C-213	2-pin connector GM	ws	white
X2	2-pin heater connector	GR	Fan controller	sw	black
X10	4-pin connector Heater control	C-219	4-pin connector GR	br	brown
K1	Fan relay	KB	A/C control panel	gn	green
F1	20A fuse	C-210	20-pin connector KB	ge	yellow
F2	30A fuse	C-415	19-pin connector of central electrical box (ZE)	bl	blue
F3	1A fuse	F1	10A fuse		
F4	25 A fuse				
IPCU	Pulse width modulator				
IPCU adjustment values:					
Duty cycle: 100%					
Frequency: 1kHz					
Voltage: 4.2V				X	Cutting point
Function: High-side				Wiring colours may vary.	

Legend

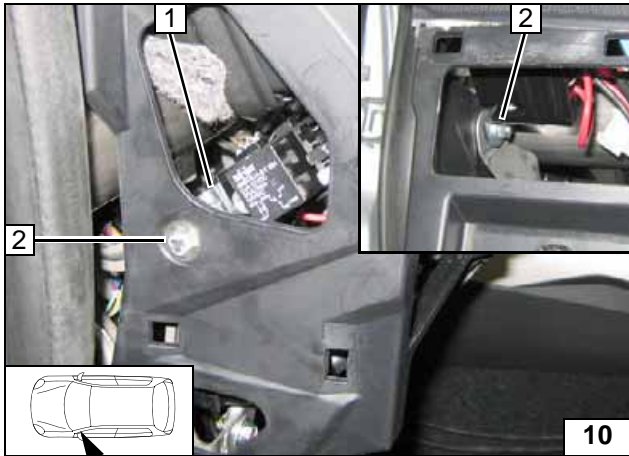

Replace original vehicle bolt at position 2 with M6x20 bolt, large diameter washer and flanged nut. Original vehicle bolt will be re-used for Telestart.

- 1 Angle bracket



Installing and connecting fuse holder of passenger compartment

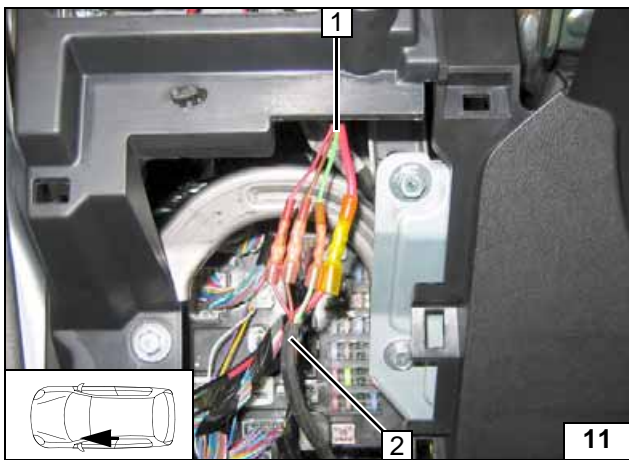

Connect wiring harness of passenger compartment fuse holder 1 to wiring harness of heater 2 according to wiring diagram, in such a way that the wires of the same colour are connected to each other.



Connecting wiring harnesses

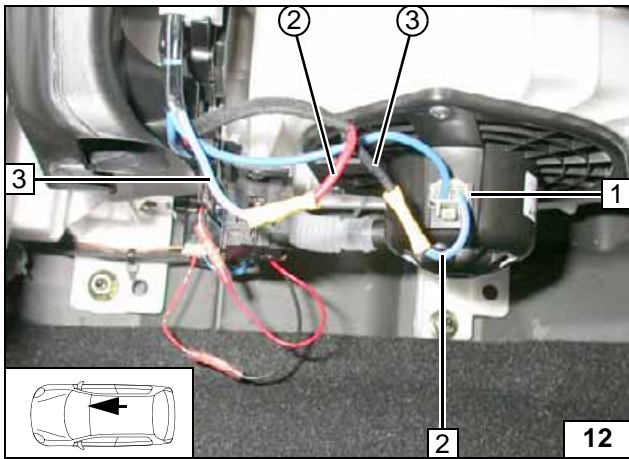

Connection to 2-pin connector C-213 1 from the fan motor. Produce connections as shown in wiring diagram.

- 2 Blue (bl) wire of C-213 connector, Pin 1
- 3 Blue (bl) wire of fan relay, central electrical box
- ② Red (rt) wire of K1/87a
- ③ Black (sw) wire of K1/30



Connecting fan motor

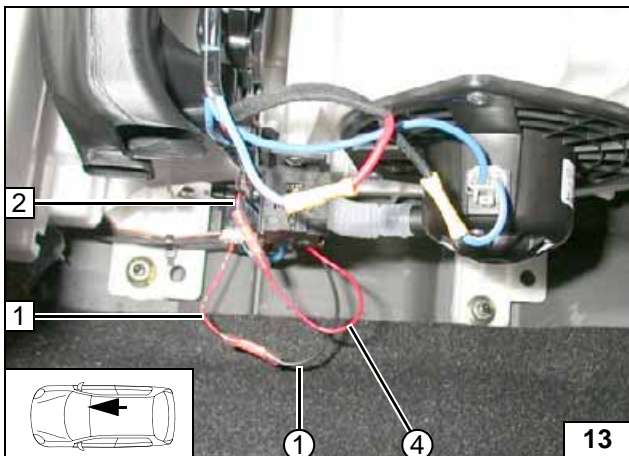

Additional black (sw) wire of K1/86 ⑤ to IPCU/86.

- 1 Red (rt) A/C control unit
- 2 Red (rt) wire of fan controller
- ① Black (sw) wire of IPCU/A
- ④ Red (rt) wire of IPCU/E



Connecting IPCU

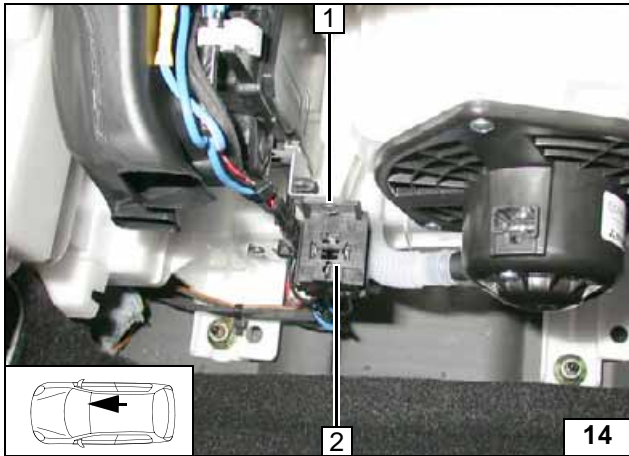

- 1 Original vehicle bolt
- 2 IPCU socket

Installing IPCU

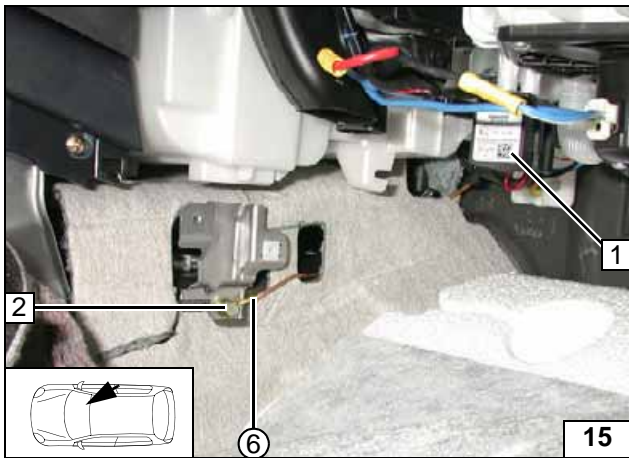

Produce connections as shown in wiring diagram.

- 1 IPCU mounted
- 2 Original vehicle earth point
- ⑥ Brown (br) wire of IPCU/85 socket



**Connect-
ing earth
wire**



Digital Timer

- 1 Digital timer



Installing digital timer

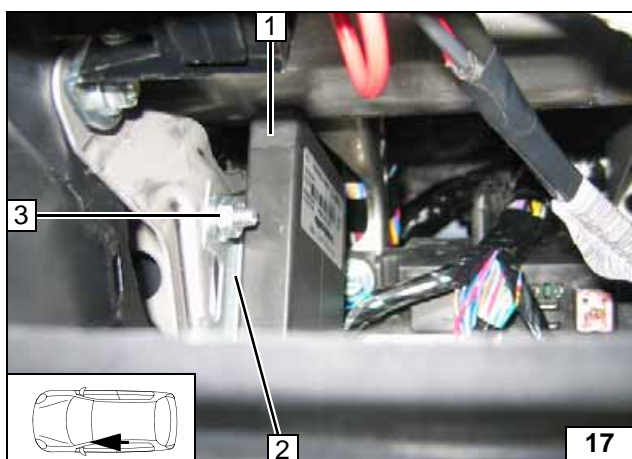

Remote Option (Telestart)

- 1 Receiver
- 2 Bracket
- 3 Original vehicle bolt, flanged nut



Installing receiver

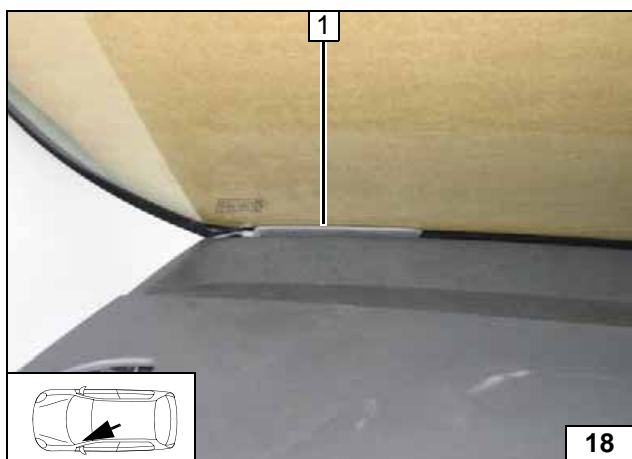

- 1 Antenna

Installing antenna

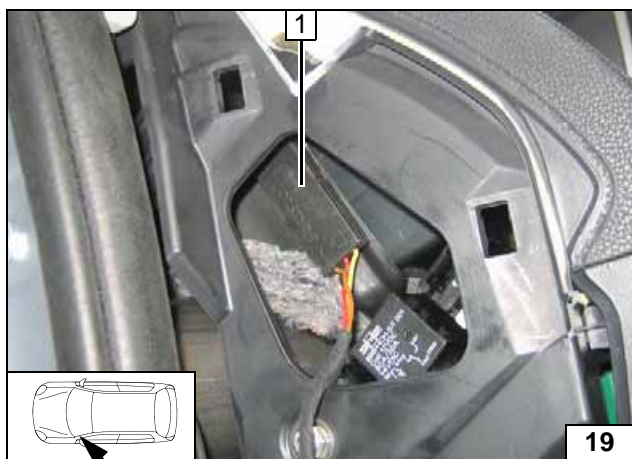

Temperature sensor T100 HTM

Fasten temperature sensor 1 with adhesive tape.



Installing temperature sensor

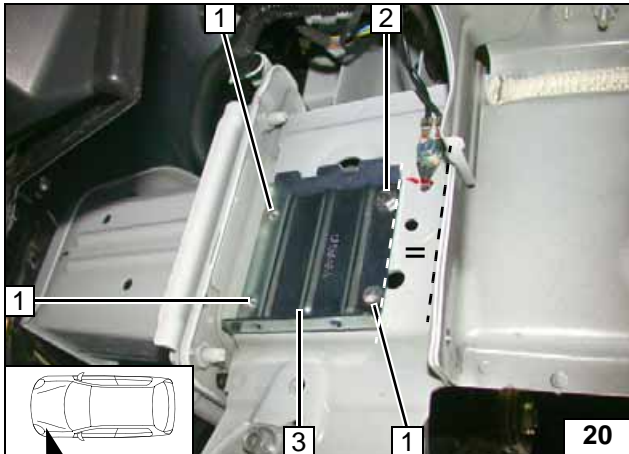

Preparing Installation Location

Align bracket section A 3 so that it is parallel to the edge.

- 1 Copy hole pattern [3x]
- 2 M6x30 bolt, original vehicle threaded hole



Copying hole pattern

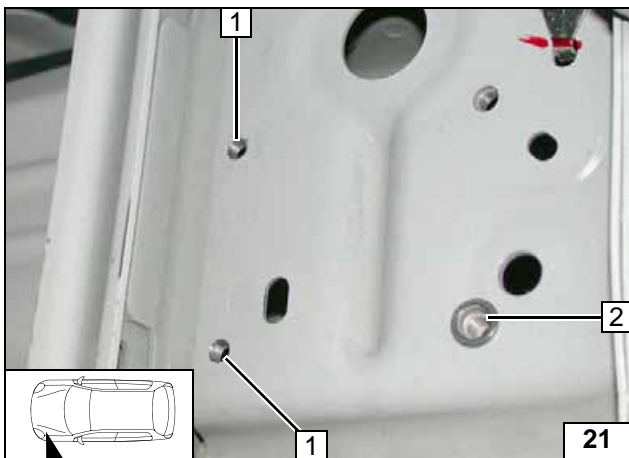

Remove bracket A.

- 1 4.8mm dia. hole; Cut M6 thread [2x each]
- 2 9.1 mm dia. hole; rivet nut



Installing rivet nut

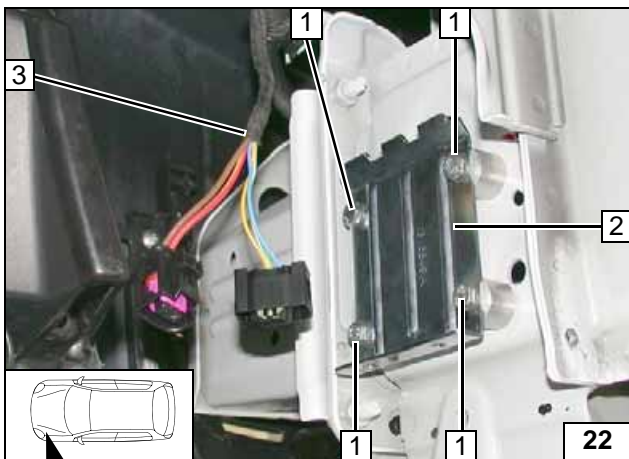

- 1 M6x30 bolt, spring lockwasher, 15mm shim [4x each]
- 2 Bracket
- 3 Wiring harness of heater

Installing bracket section A

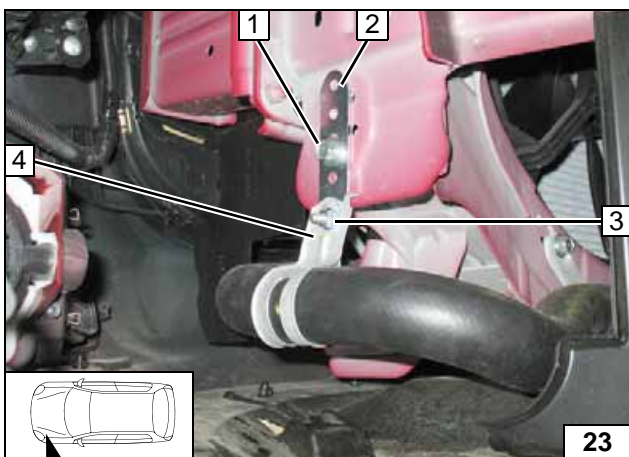

1.6 B

Unscrew bracket of radiator hose 4 at position 1.

- 1 Original vehicle bolt
- 2 Perforated bracket
- 3 M6x20 bolt, flanged nut



Displacing radiator hose

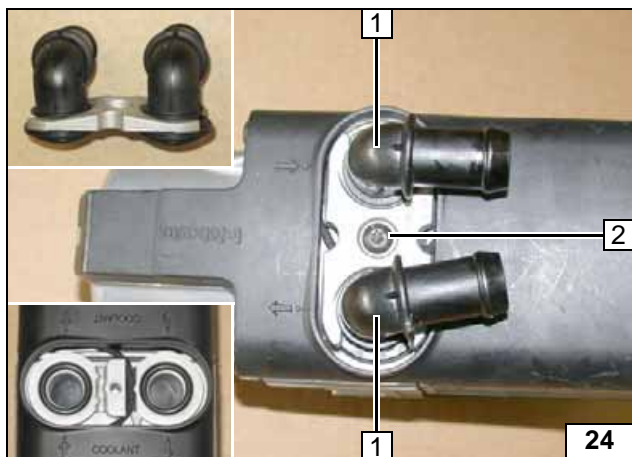

Preparing Heater

- 1 Water connection piece, sealing ring [2x each]
- 2 5x15 self-tapping bolt, retaining plate of water connection pieces



Installing water connection pieces

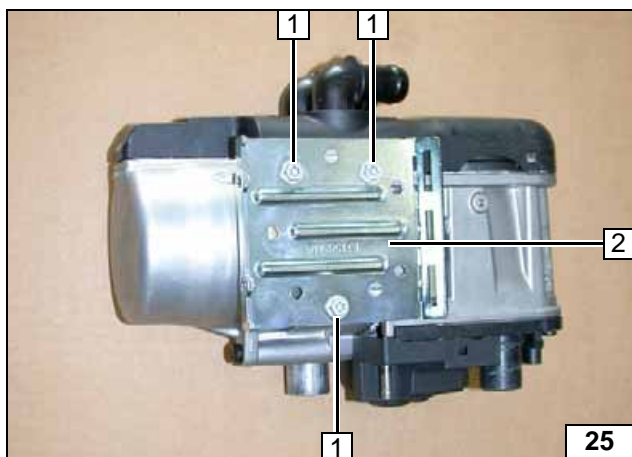

- 1 5x13 self-tapping bolt [3x]
- 2 Bracket



Installing bracket section B

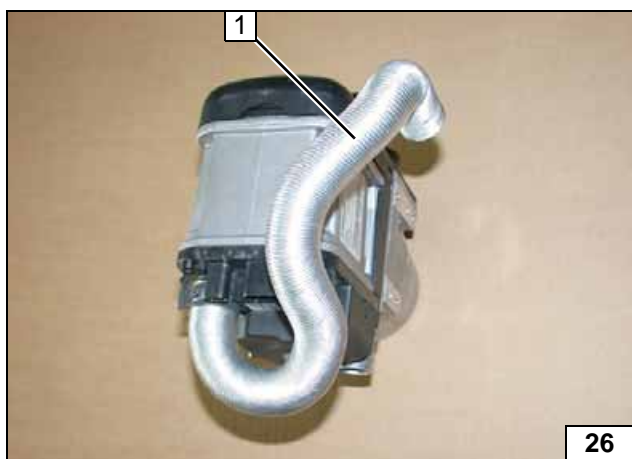

- 1 Combustion air pipe



Premounting combustion air pipe

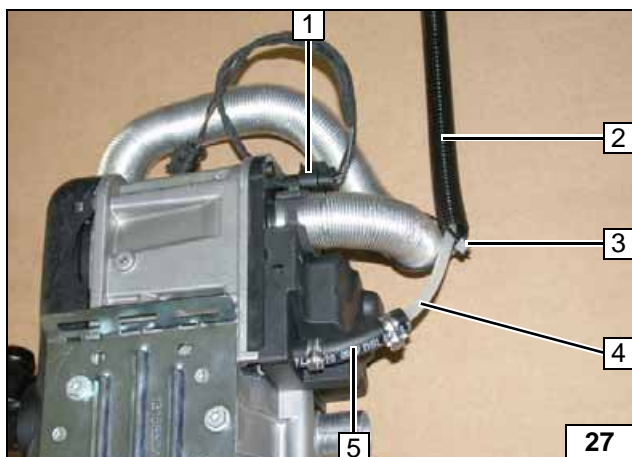

Pull fuel line 4 into 10mm dia. corrugated tube 2.

- 1 Attach wiring harness of circulating pump
- 3 Cable tie
- 5 Hose section, 10 mm dia. clamp [2x]



Premounting fuel line

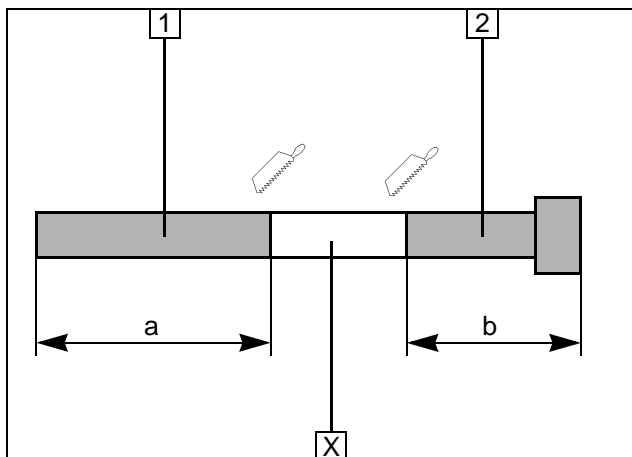

Discard section X

- 1 Exhaust pipe
a = 350
- 2 Exhaust end section
b = 320



Preparing exhaust pipe

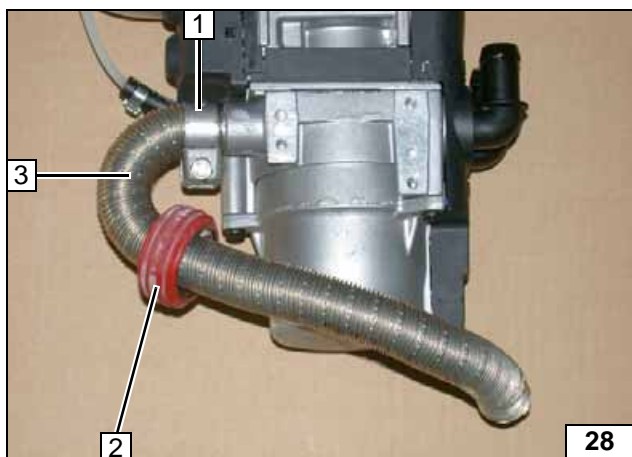

- 1 Hose clamp
- 2 Spacer bracket
- 3 Exhaust pipe

Preassembling exhaust pipe

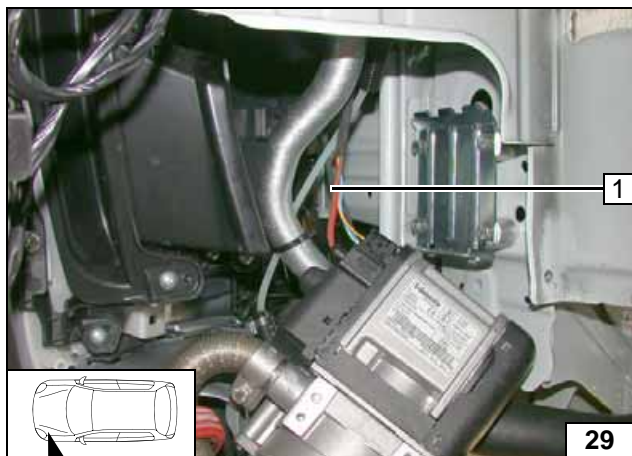

Installing Heater

- 1 Wiring harness of heater [2x]

Mounting wiring harness of heater

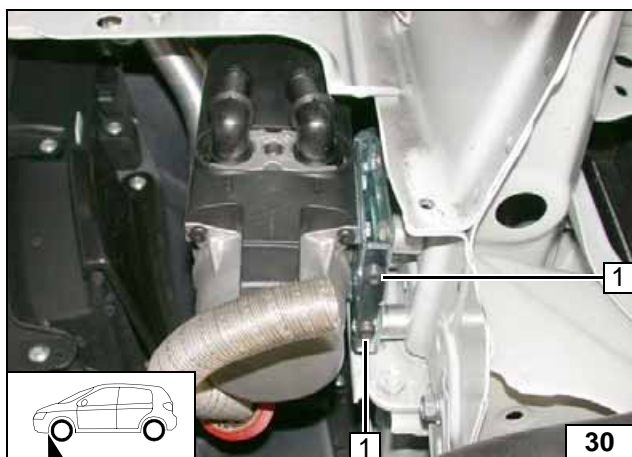

Insert heater with bracket section B into bracket section A.

- 1 M5x12 Torx screw [2x]



Installing heater

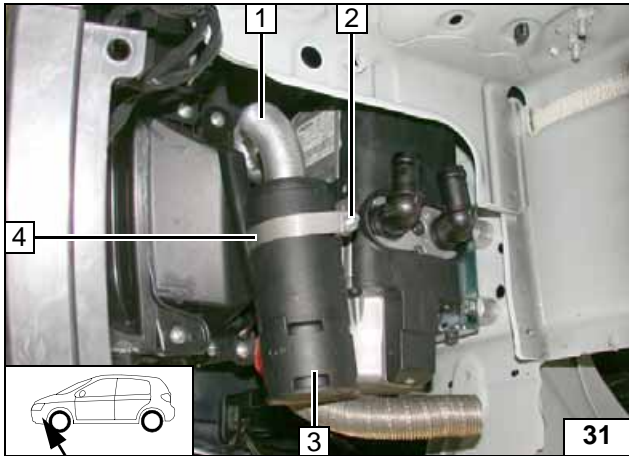
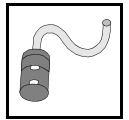

Combustion Air

- 1 Combustion air pipe
- 2 M5x16 bolt
- 3 Silencer
- 4 51mm dia. clamp



**Installing
silencer**

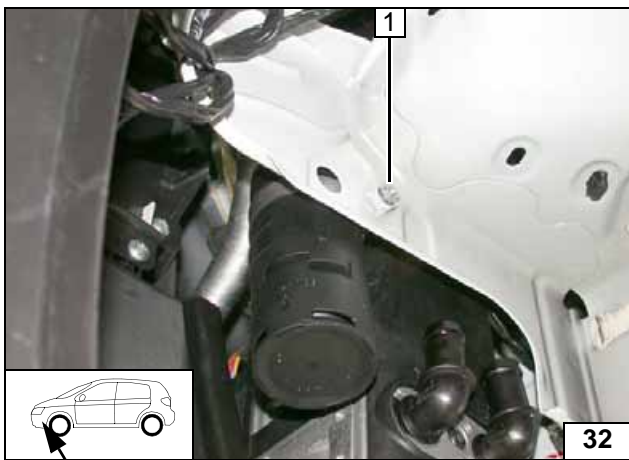

Lead M5x16 bolt through original vehicle hole.

- 1 M5 flanged nut



**Installing
silencer**

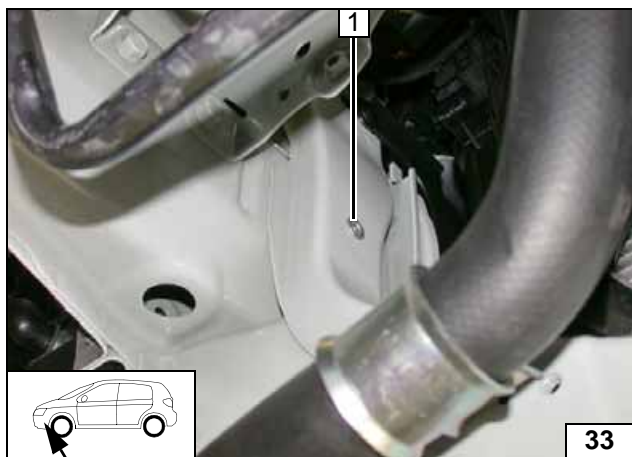

Preparing Coolant Circuit

Images concerning the installation of the circulating pump show 2.0 petrol variant.

- 1 Drill out hole to 9.1mm dia.; rivet nut

Installing rivet nut

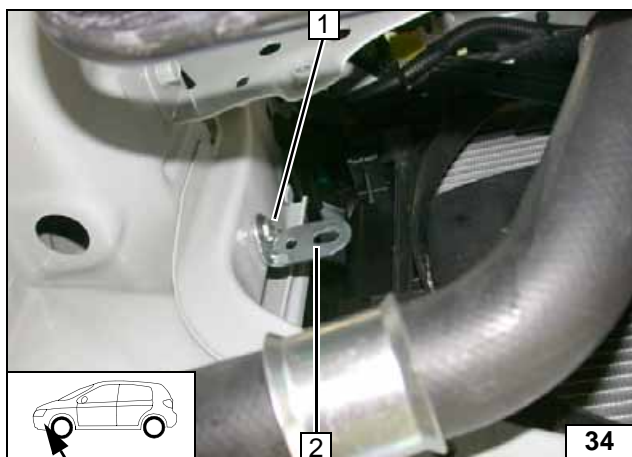

- 1 M6x20 bolt, spring lockwasher
- 2 Angle bracket

Installing angle bracket

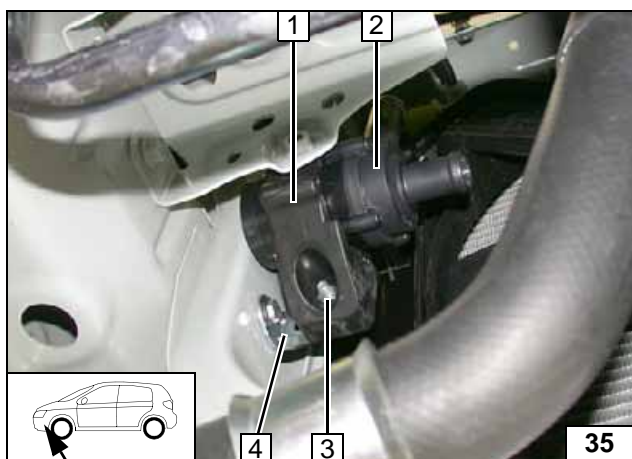

- 1 Circulating pump mounting
- 2 Circulating pump
- 3 M6x25 bolt, flanged nut
- 4 Angle bracket

Mounting circulating pump

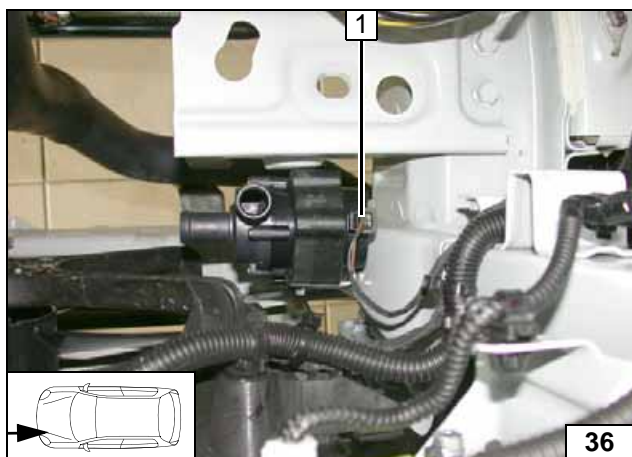

- 1 Wiring harness of circulating pump

Mounting wiring harness





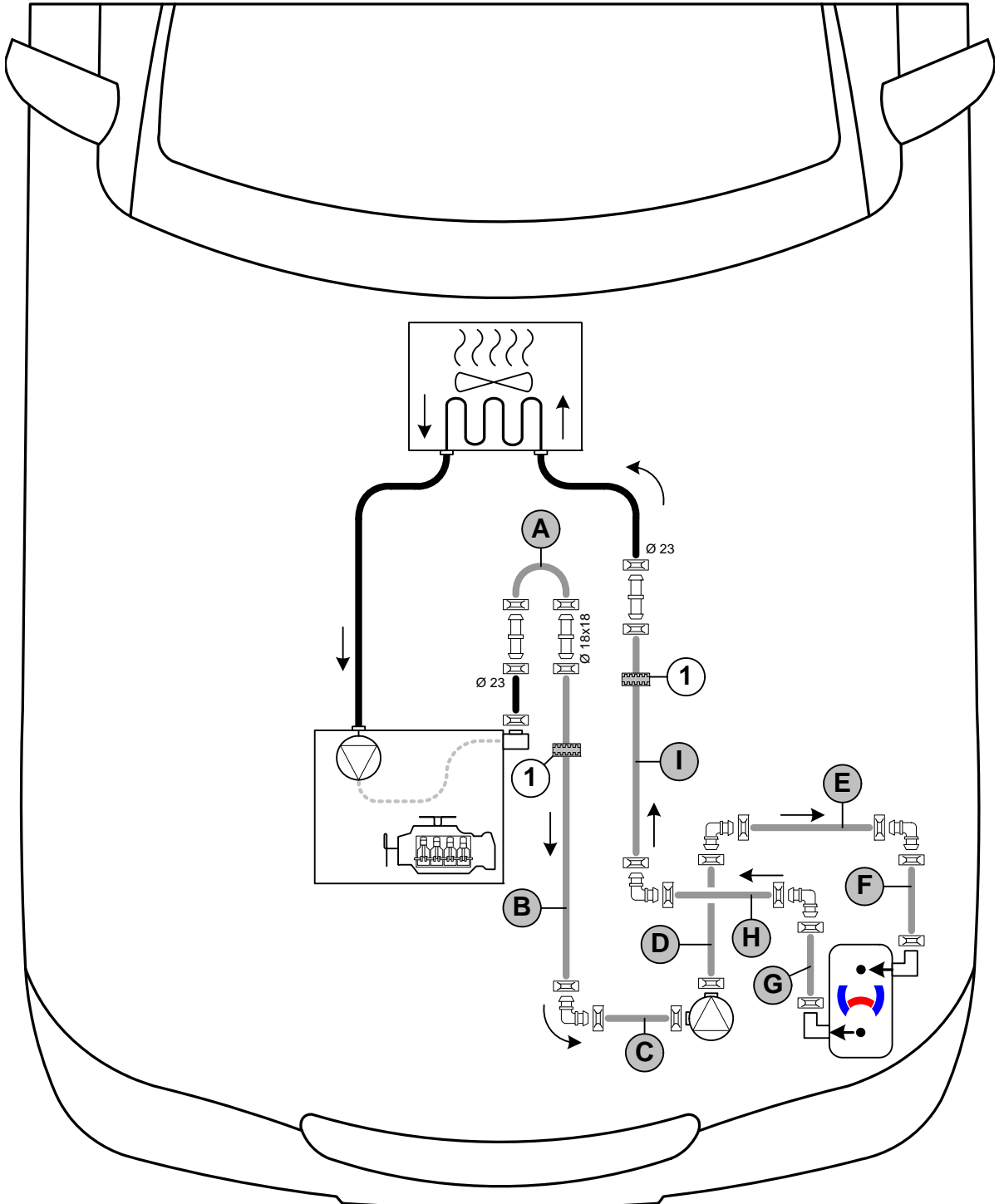

1.6 B Coolant Circuit

WARNING!

Any coolant running off should be collected in an appropriate container. Route hoses so that they are kink-free. Unless specified otherwise, always fasten using cable ties. Position clamps so that other hoses cannot be damaged. When installing the hoses, the heater must be filled with coolant. The connection should be "inline" based on the following diagram:



Hose routing diagram

All spring clips without a specific designation  = 25 mm dia. **1** = Black (sw) rubber isolator .
 All connecting pipes without a specific designation  = 16x18mm dia.
 All connecting pipes  = 18x18 mm dia.



Citroen C4 Aircross

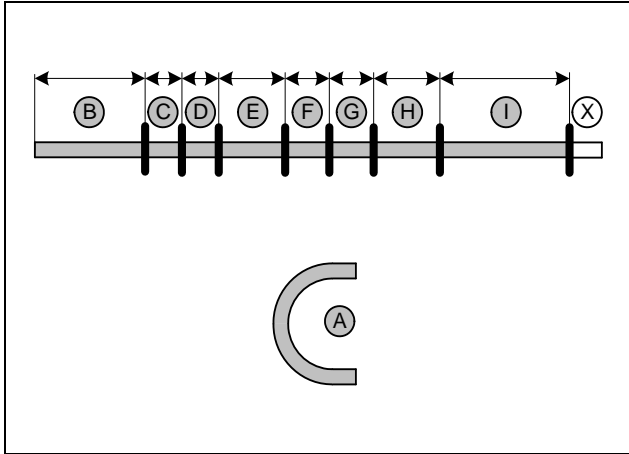

Discard section **X**.
Hose **A** = 180°, 18mm dia. moulded hose

- B** = 510
- C** = 60
- D** = 60
- E** = 260
- F** = 150
- G** = 130
- H** = 345
- I** = 530



Cutting hoses to length

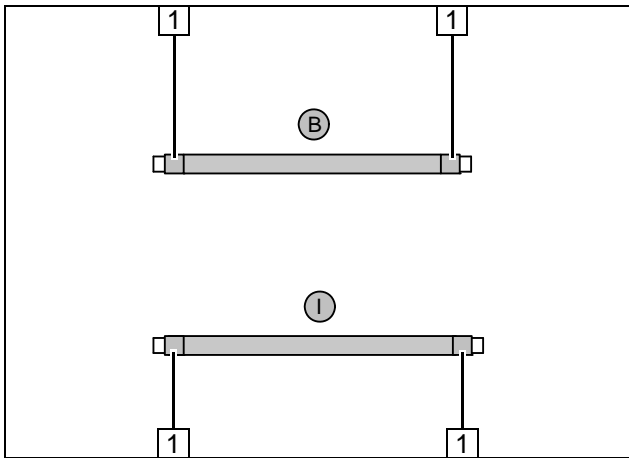

Push braided protection hoses onto hose **B** and **I** and cut to length. Cut heat shrink plastic tubing to length.

- 1** 50 mm long heat shrink plastic tubing [4x]



Preparing hoses

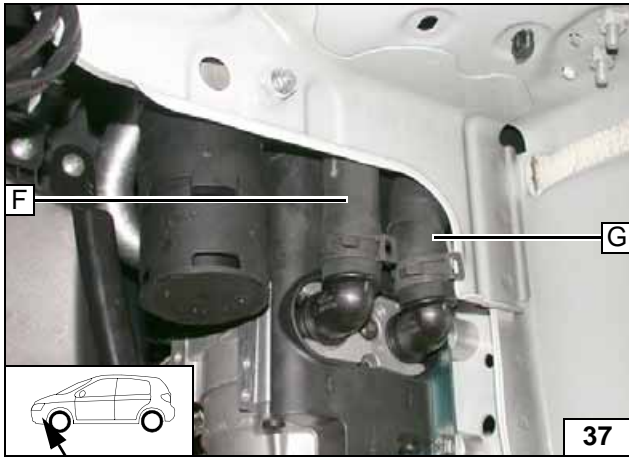

Push hoses **F** and **G** through from above, see following image.



Connecting heater

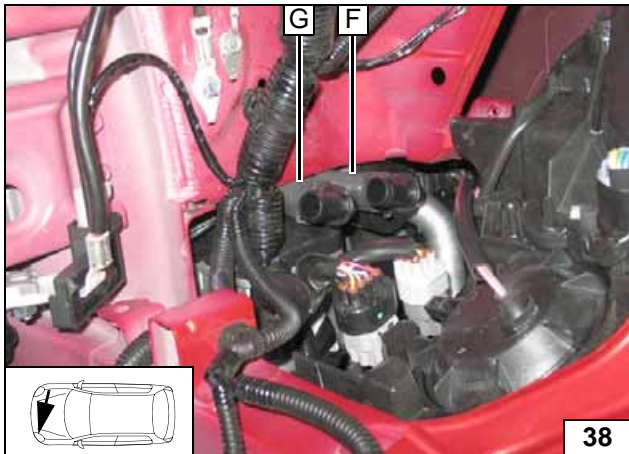

Installing connecting pipes

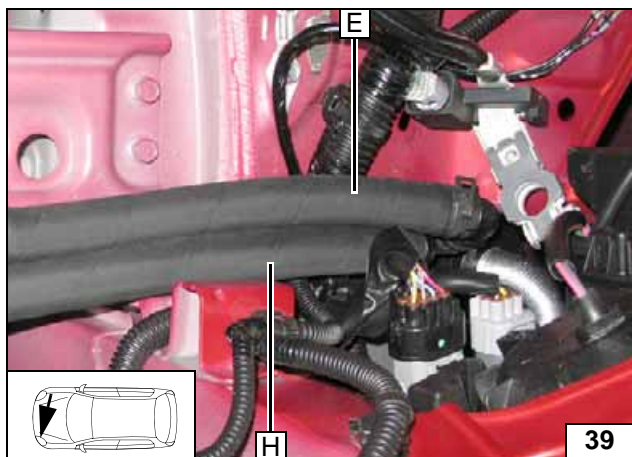

Connect hoses **G** and **H** as well as hoses **F** and **E**.



Routing in engine compartment

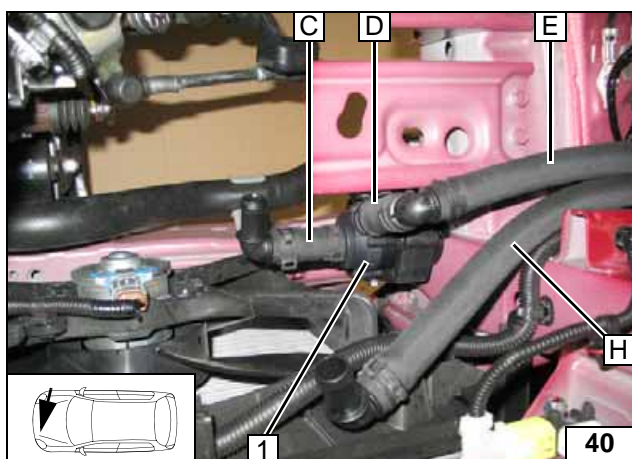

1 Circulating pump



Connecting circulating pump

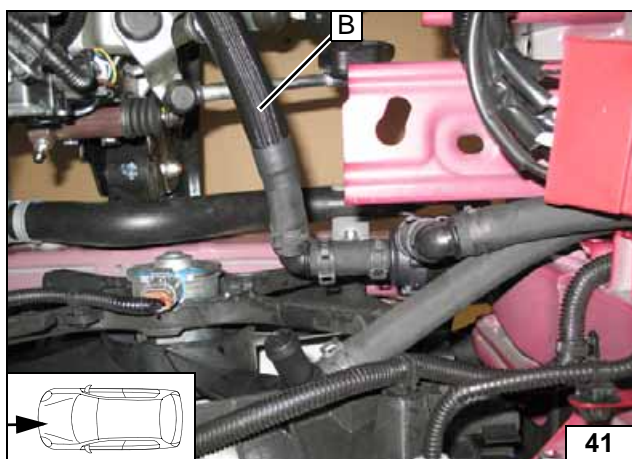

Routing in engine compartment

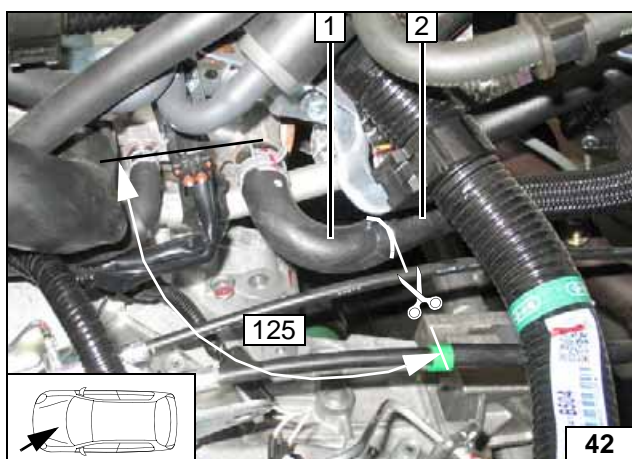

Cut off hose on engine outlet/heat exchanger inlet at marking.



- 1 Engine outlet hose section
- 2 Hose section of heat exchanger inlet

Cutting point

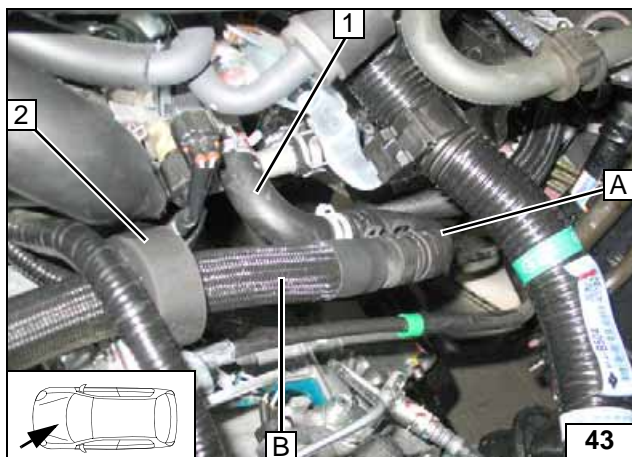

Push black (sw) rubber isolator 2 onto hose B.



- 1 Hose of engine outlet

Connect-
ing engine
outlet

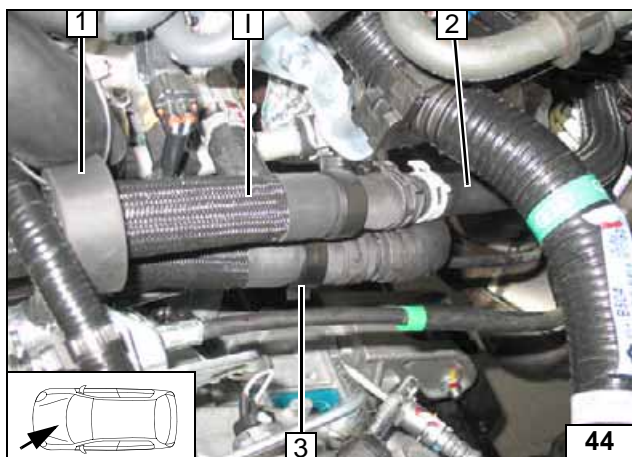

Push black (sw) rubber isolator 1 onto hose I and fasten it to the charge-air tube using cable ties.



- 2 Hose on heat exchanger inlet
- 3 Insert hose bracket

Conne-
tion of heat
exchanger
inlet

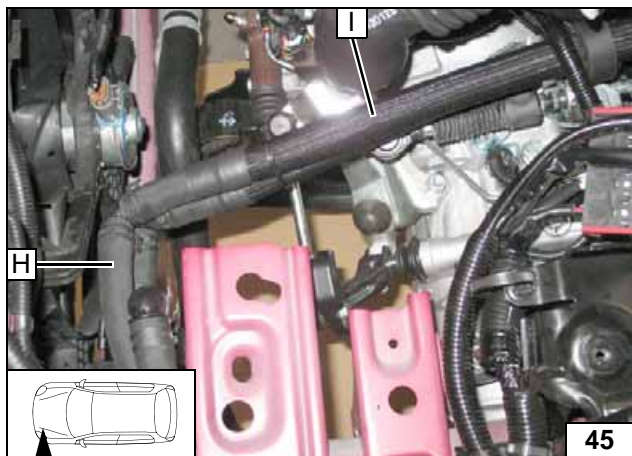

Connect hoses I and H.



Routing in
engine
compart-
ment

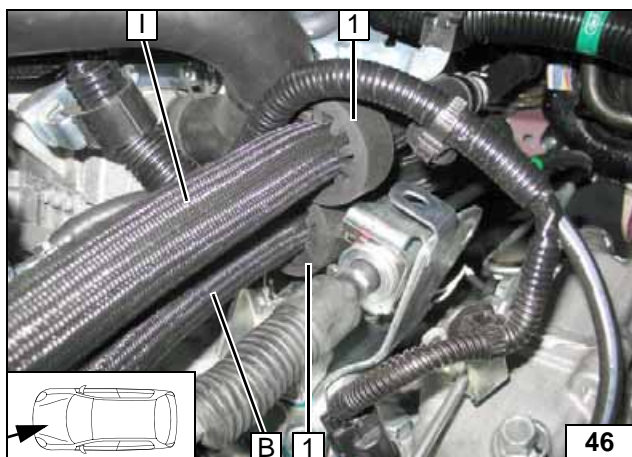

- 1 Black (sw) rubber isolator [2x]

Aligning
rubber iso-
lator

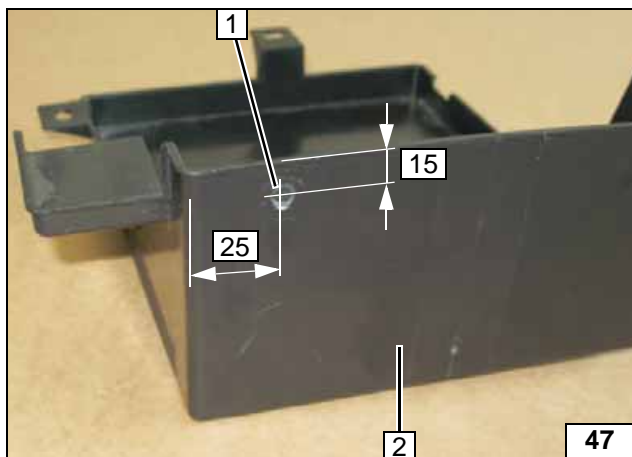

- 1 7 mm dia. hole
- 2 Battery carrier

Hole in battery carrier

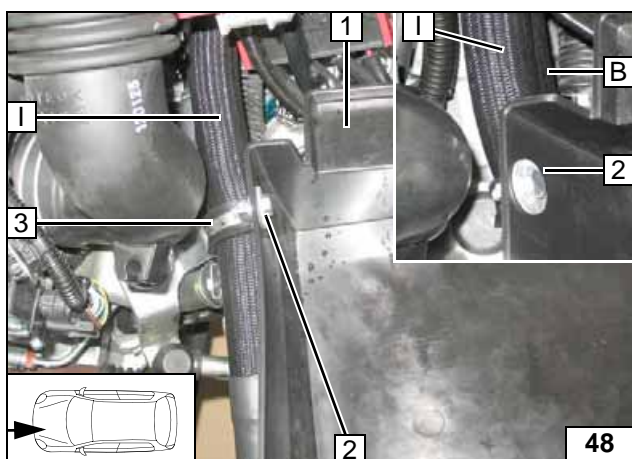

Ensure sufficient distance of hoses I and B to charge-air tube.



- 1 Install battery carrier
- 2 M6x20 bolt, large diameter washer, flanged nut
- 3 38 mm dia. rubber-coated p-clamp

Fastening hoses I and B

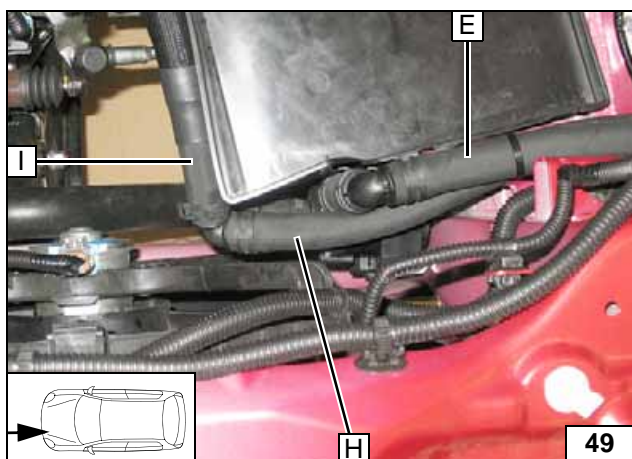

Ensure sufficient distance between hose H and battery box.



Aligning hoses

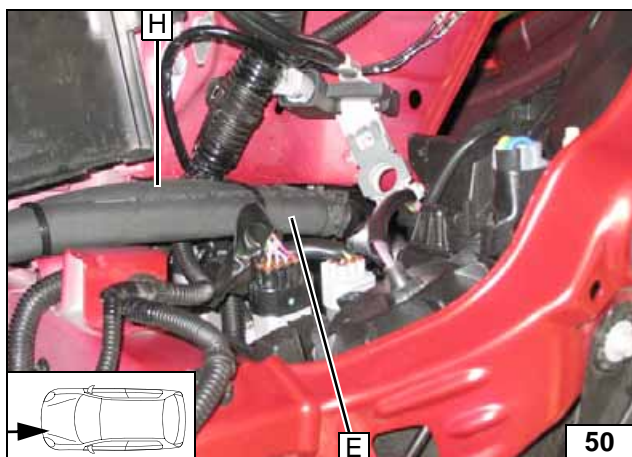

Align hoses. Ensure sufficient distance to adjacent components (especially with regard to the combustion air pipe), correct if necessary.



Aligning hoses





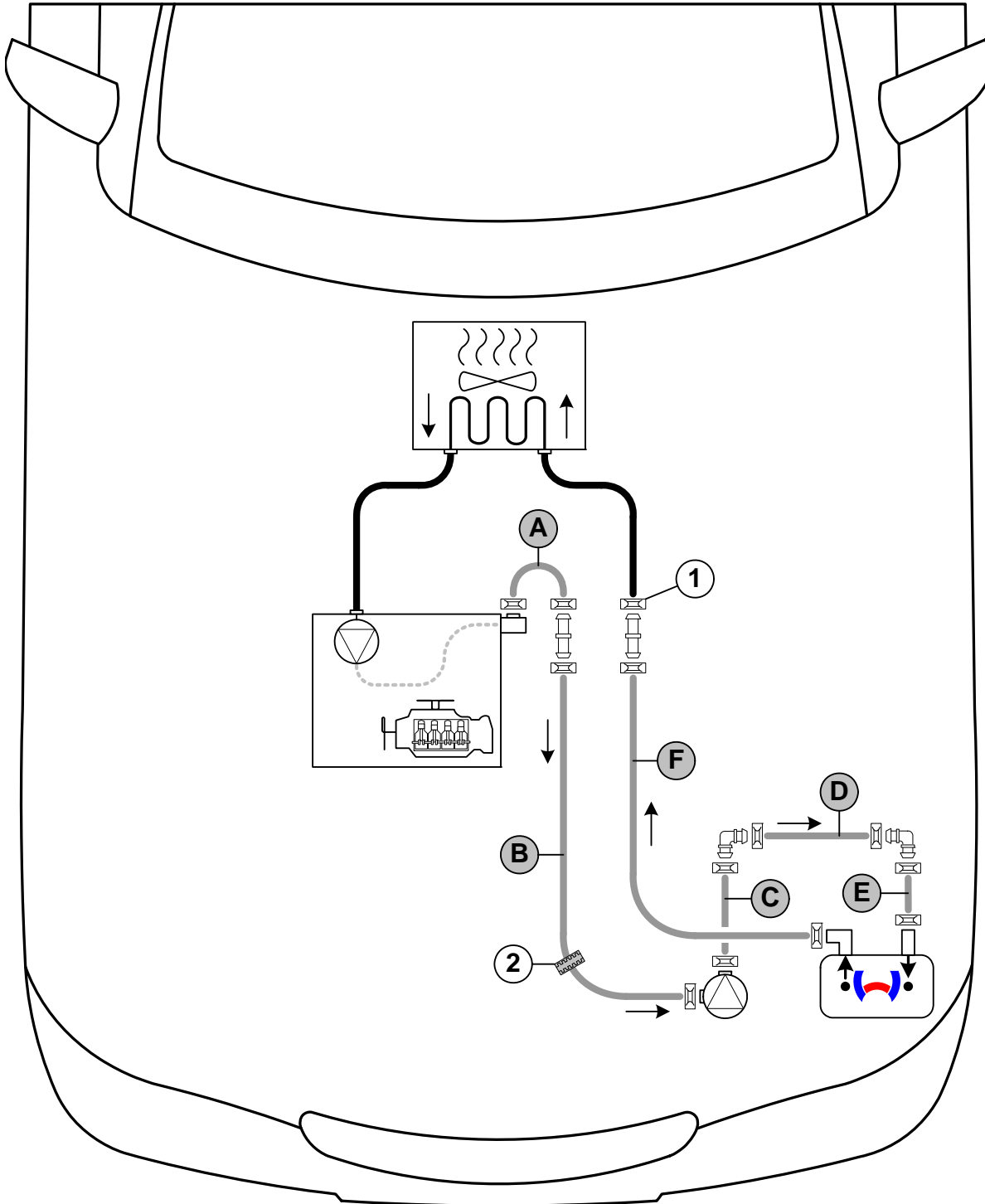

2.0 B Coolant Circuit

WARNING!

Any coolant running off should be collected in an appropriate container. Route hoses so that they are kink-free. Unless specified otherwise, always fasten using cable ties. Position clamps so that other hoses cannot be damaged. When installing the hoses, the heater must be filled with coolant. The connection should be "inline" based on the following diagram:



Hose routing diagram

All spring clips without a specific designation  = 25 mm dia.
1 = Original vehicle spring clip  . **2** = Black (sw) rubber isolator  .
 All connecting pipes  and  = 18x18 mm dia.



Citroen C4 Aircross

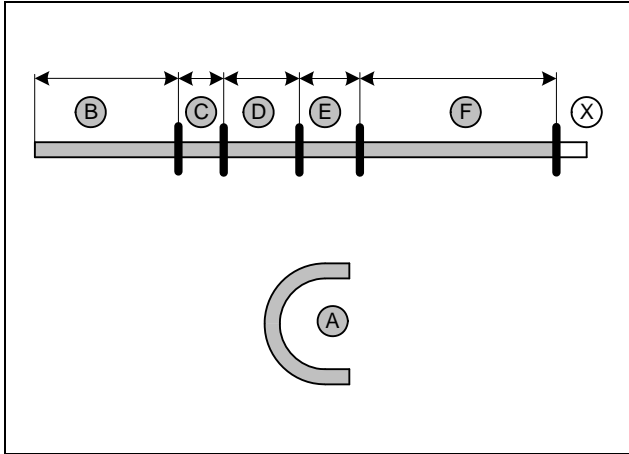

Discard section X.
Hose A = 180°, 18mm dia. moulded hose

- B = 610
- C = 60
- D = 240
- E = 150
- F = 990



Cutting hoses to length

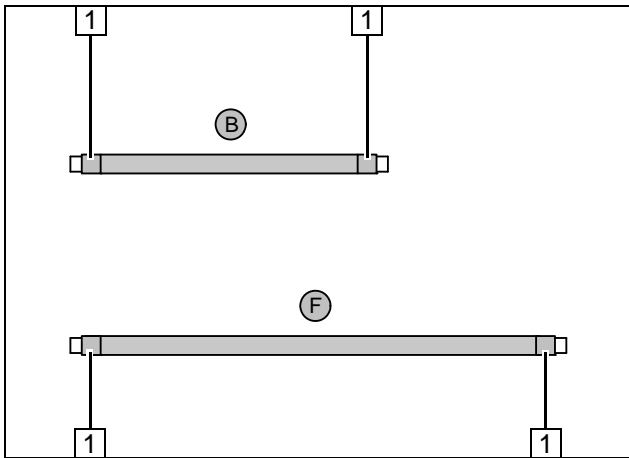

Push braided protection hoses onto hose B and F and cut to length. Cut heat shrink plastic tubing to length.

- 1 50 mm long heat shrink plastic tubing [4x]



Preparing hoses

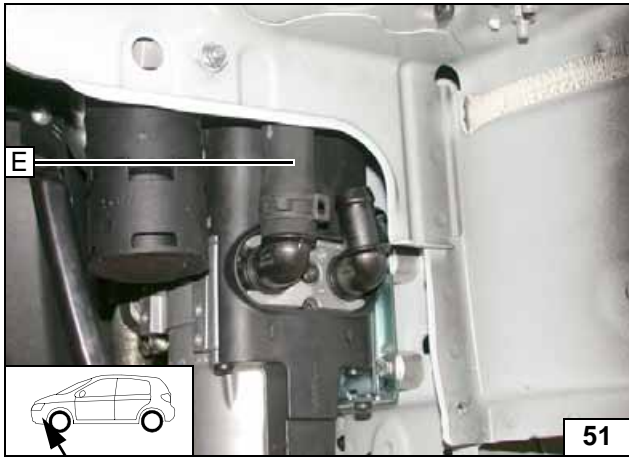

**Connect-
ing heater
inlet**

- 1 Circulating pump

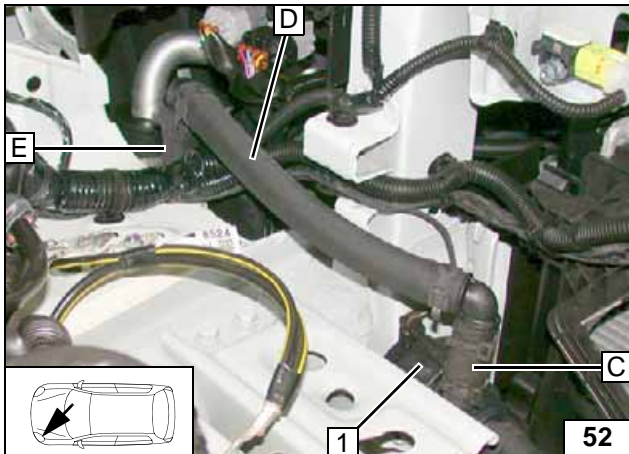

**Routing in
engine
compartment**

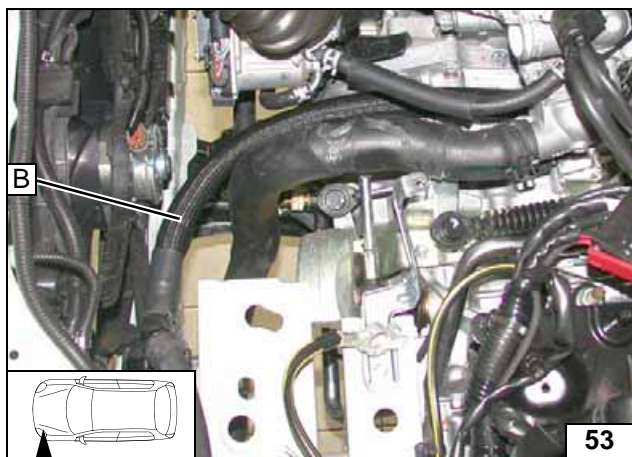

Routing in engine compartment

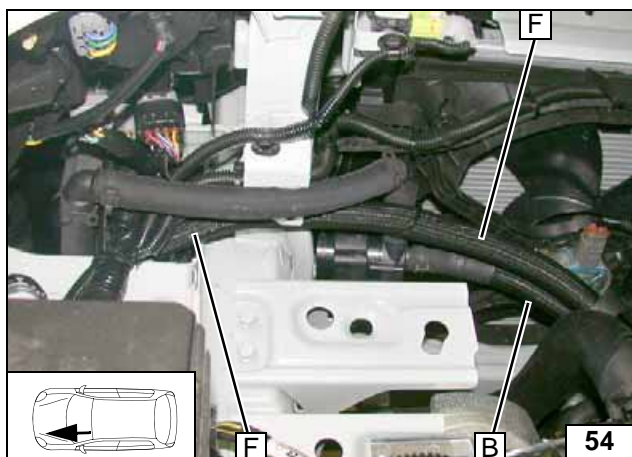

Route hose F to the heater and to the cutting point along hose B.



Routing in engine compartment

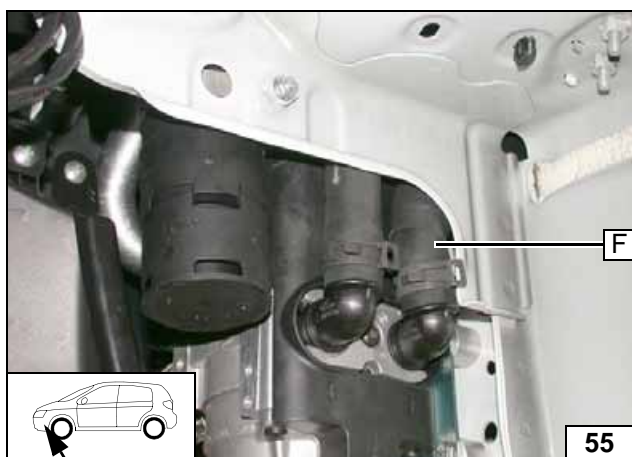

Connecting heater outlet

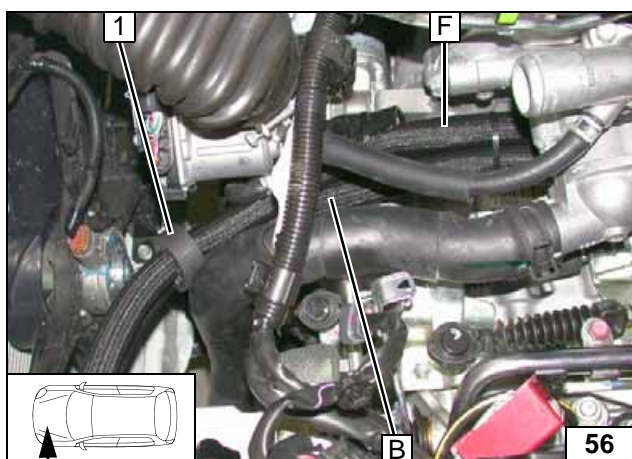

Push black (sw) rubber isolator 1 onto hose F.



Routing in engine compartment

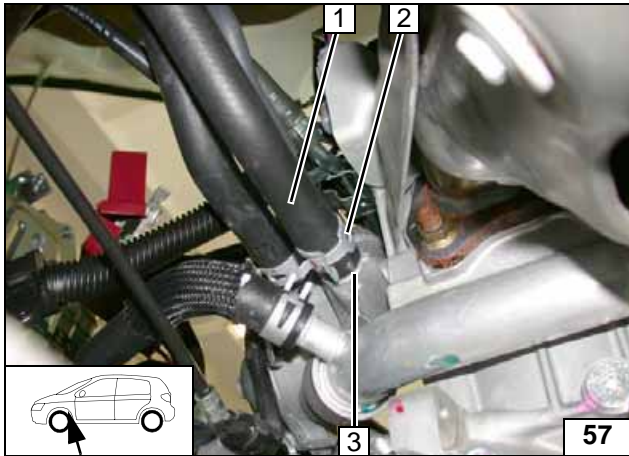

Pull hose of engine outlet / heat exchanger inlet **1** off the connection piece of engine outlet **3**. Spring clip **2** will be reused.

Cutting point

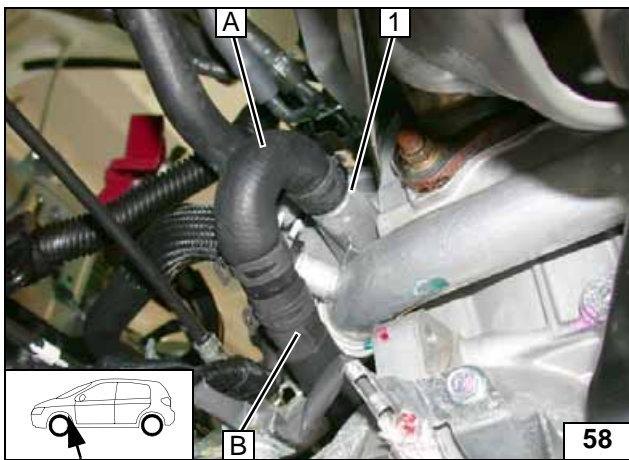

1 Connection piece for engine outlet

Connecting engine outlet

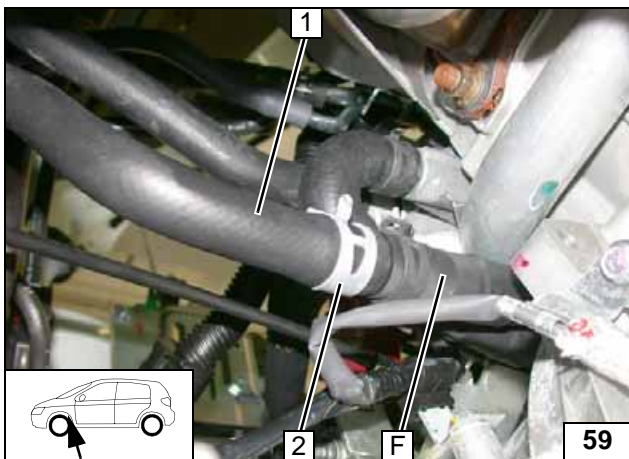

1 Hose on heat exchanger inlet
2 Original vehicle spring clip

Connection of heat exchanger inlet

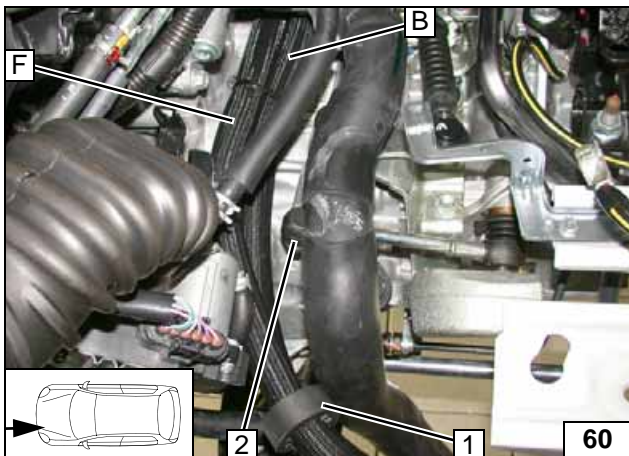

Align black (sw) rubber isolator **1** to the radiator hose. Align hoses. Ensure sufficient distance from adjacent components, correct if necessary. Observe minimum distance of 25mm between hose **B** and the gear change at position **2**.



Routing in engine compartment

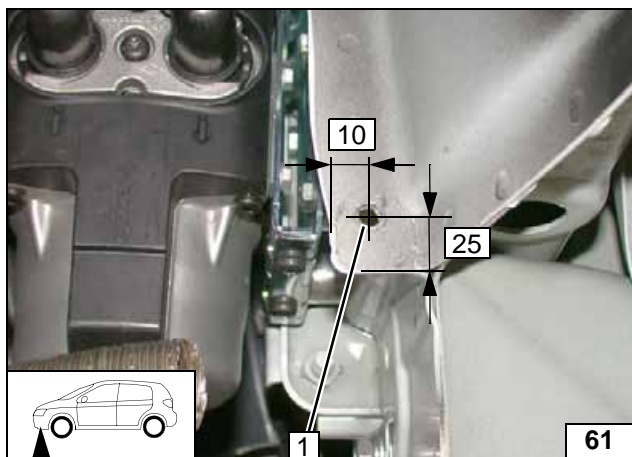
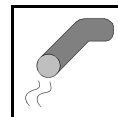

Exhaust Gas

- 1 7 mm dia. hole

Hole in cross member

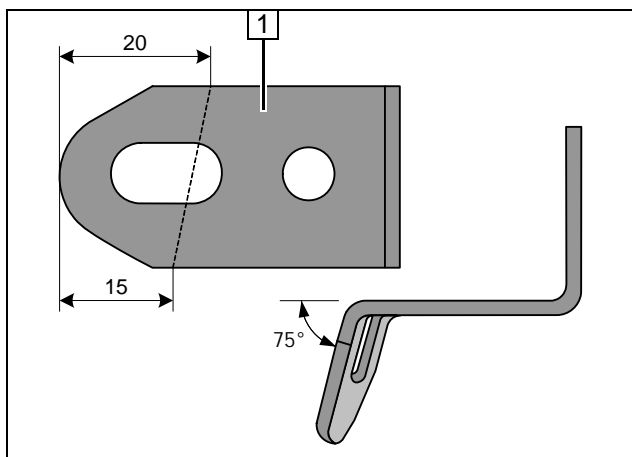

- 1 Angle bracket

Preparing angle brackets

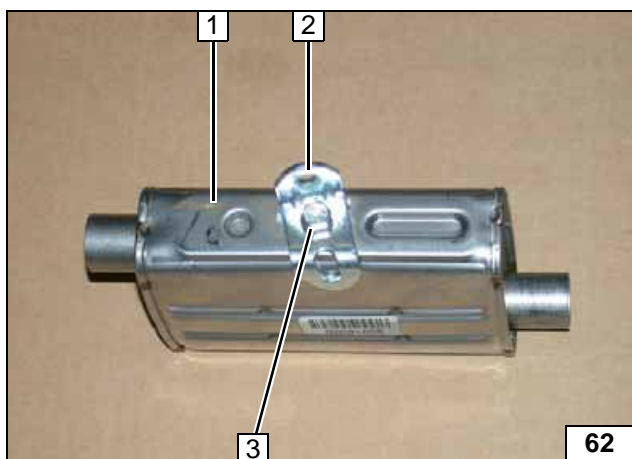

- 1 Silencer
- 2 Angle bracket
- 3 M6x16 bolt, spring lockwasher

Premounting silencer

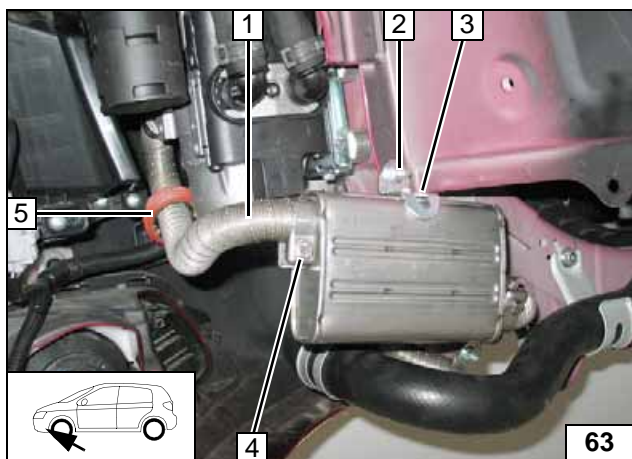

1.6 B

- 1 Exhaust pipe
- 2 M6x20 bolt, spring lockwasher, flanged nut
- 3 Angle bracket
- 4 Hose clamp
- 5 Align spacer bracket

Installing exhaust pipe and silencer

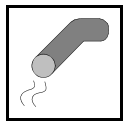

Installing
exhaust
end section

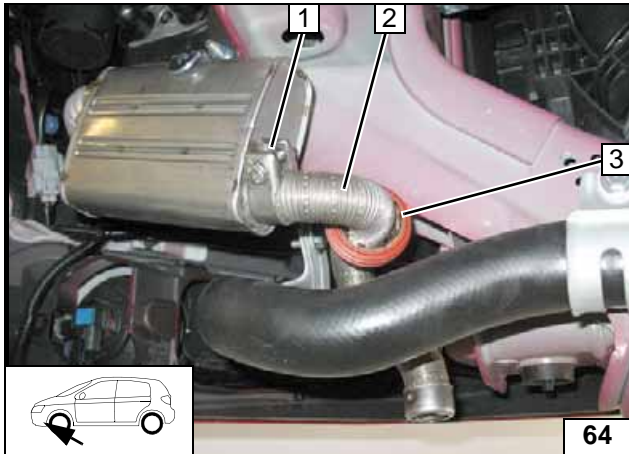

Push spacer bracket 3 onto exhaust end section 2 and position it above the radiator hose.

- 1 Hose clamp

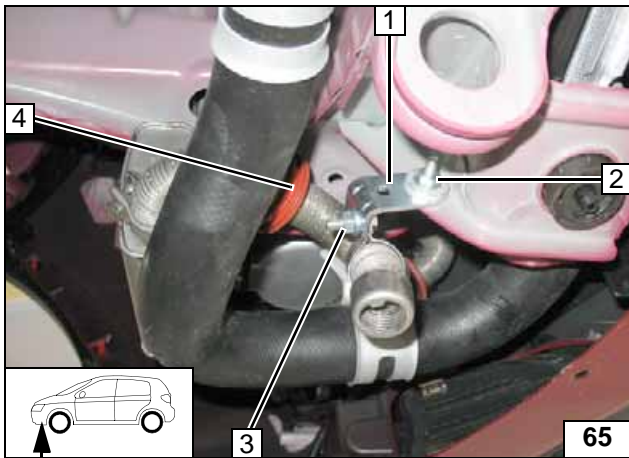

- 1 Angle bracket
- 2 M6x20 bolt, large diameter washer, flanged nut, existing hole
- 3 M6x20 bolt, p-clamp, flanged nut
- 4 Align spacer bracket

Installing
exhaust
end section

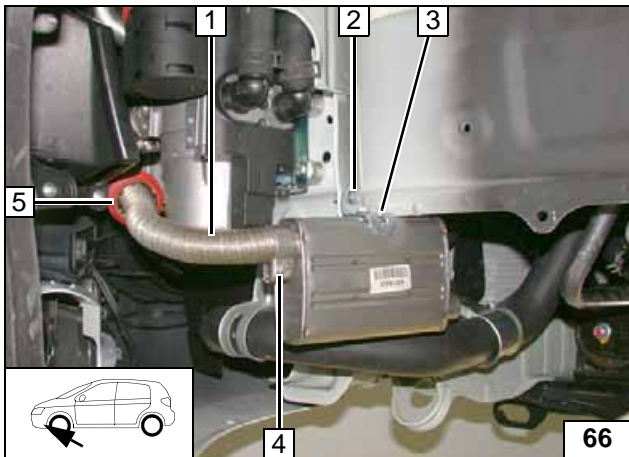

2.0 B

- 1 Exhaust pipe
- 2 M6x20 bolt, spring lockwasher, flanged nut
- 3 Angle bracket
- 4 Hose clamp
- 5 Align spacer bracket

Installing
exhaust
pipe and si-
lencer

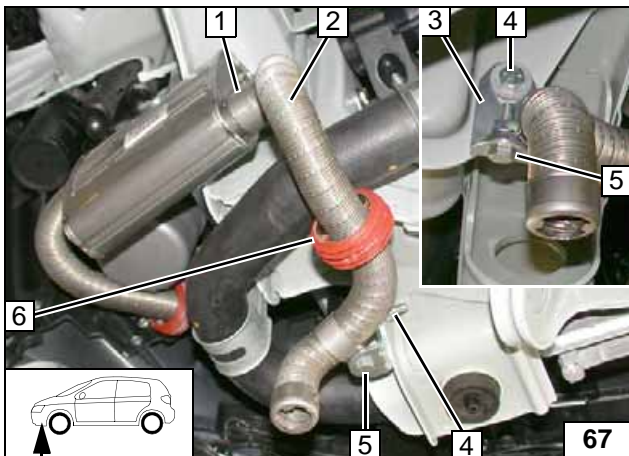

Push spacer bracket 6 onto exhaust end section 2 and position it on the radiator hose.

- 1 Hose clamp
- 3 Angle bracket
- 4 M6x20 bolt, large diameter washer, flanged nut, existing hole
- 5 M6x20 bolt, p-clamp, flanged nut



Installing
exhaust
end section



Fuel

CAUTION!

Open the vehicle's fuel tank cap, ventilate the tank and then re-close the tank lock.

Catch any fuel running off in an appropriate container.

Install fuel line and metering pump wiring harness so that they are protected against stone impact. Unless specified otherwise, always fasten using cable ties.

Mount the fuel line and wiring harness with rub protection on sharp edges.

WARNING!

The fuel line and wiring harness are routed to the metering pump as shown in the wiring harness routing diagram.

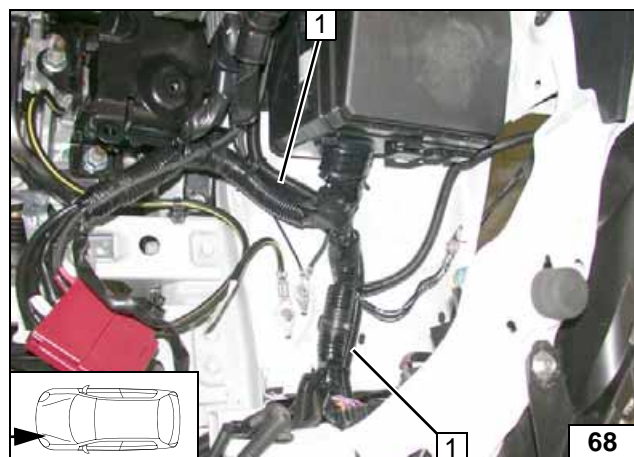

Route fuel line and wiring harness of metering pump in corrugated tube 1 to the firewall

Installing lines

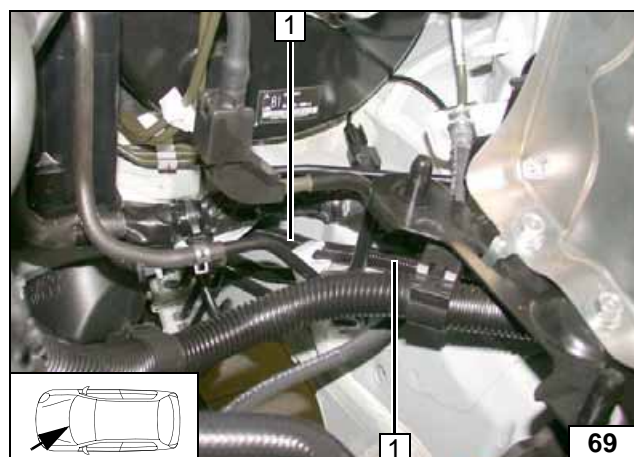

Route fuel line and wiring harness of metering pump in corrugated tube 1 to the underbody on original vehicle fuel lines.



Installing lines

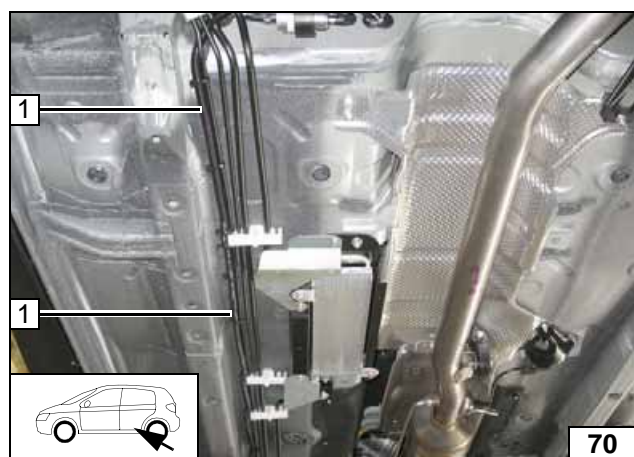

Route fuel line and wiring harness of metering pump in corrugated tube 1 to the installation location of the metering pump on original vehicle fuel lines.



Installing lines

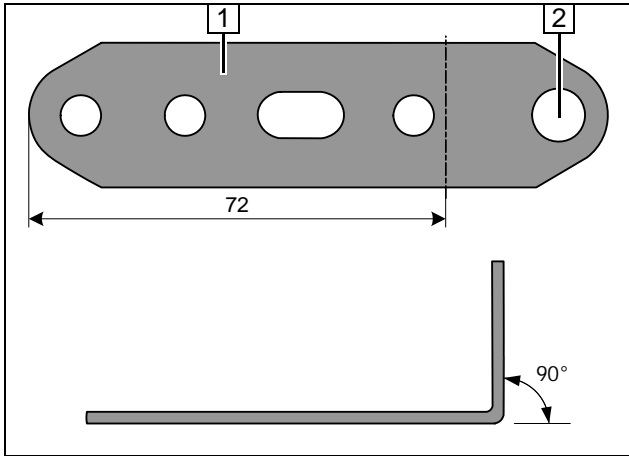
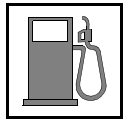

- 1 Perforated bracket
- 2 10.5 mm dia. hole

Preparing perforated bracket

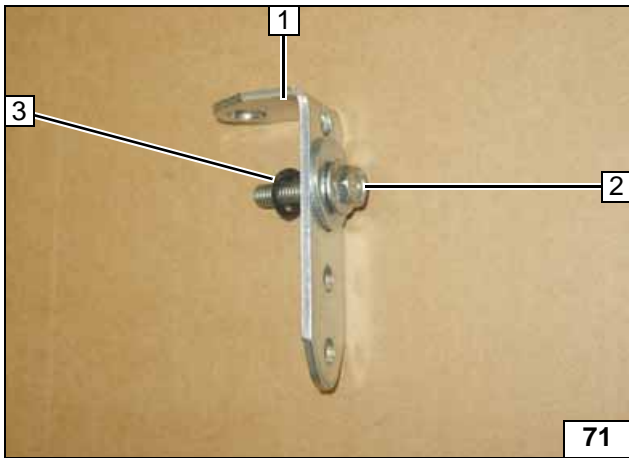

- 1 Perforated bracket
- 2 M6x25 bolt, large diameter washer
- 3 Pin lock (only push on 3 threads)

Preparing perforated bracket

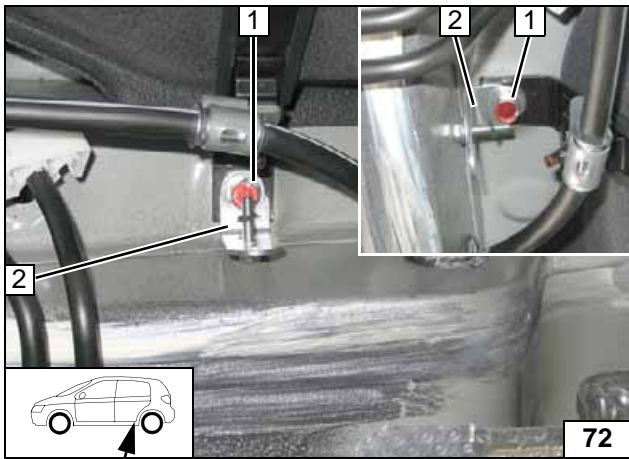

- 1 Original vehicle bolt of fuel-tank fastening
- 2 Perforated bracket

Installing perforated bracket

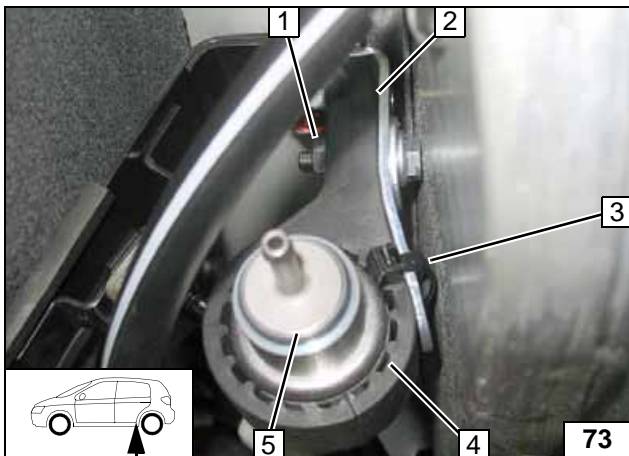

Align perforated bracket 2 after installation as shown.

- 1 Flanged nut
- 3 Cable tie
- 4 Mount of metering pump
- 5 Metering pump



Mounting metering pump

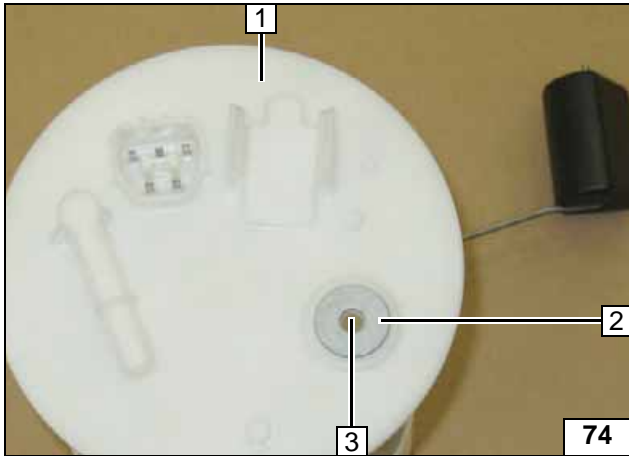
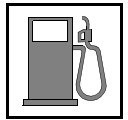

Remove fuel-tank sending unit **1** in accordance with manufacturer's instructions.

- 2** Washer outer dia. = 21.6 centrally on elevation
- 3** Copy hole pattern, 6 mm dia. hole



Fuel extraction

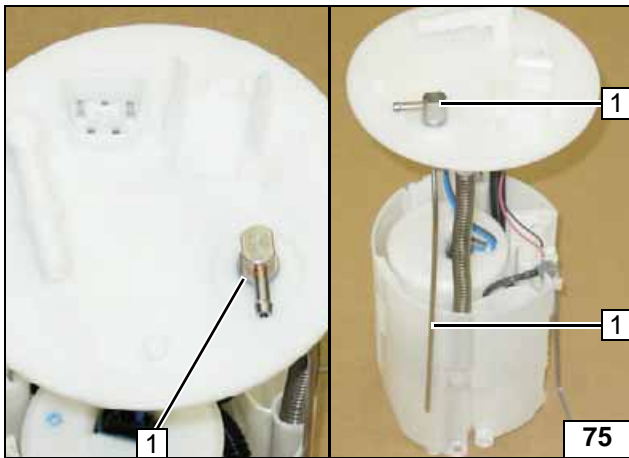

Shape fuel standpipe **1** according to template, cut to length and install.



Installing fuel standpipe

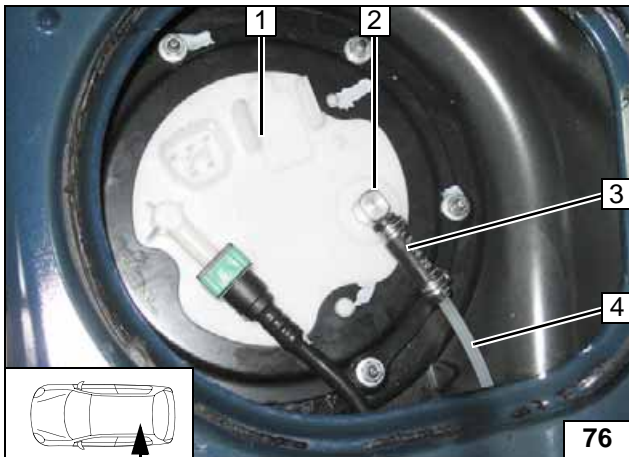

Install fuel-tank sending unit **1** in accordance with manufacturer's instructions.

- 2** Fuel standpipe
- 3** Hose section, Caillau clamp 10mm dia. [2x]
- 4** Fuel line



Connecting fuel line

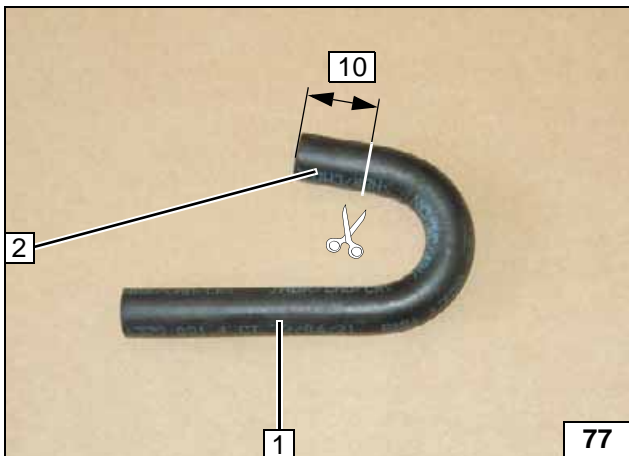

- 1** 180° moulded hose
- 2** Discard section

Shortening moulded hose

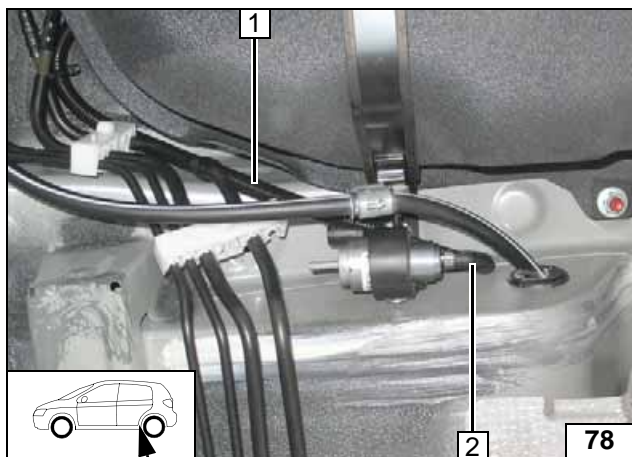

Push 10mm dia. corrugated tube 1 onto fuel line of fuel standpipe.

- 2 Fuel line of fuel standpipe, 180° moulded hose, 10 mm dia. clamp [2x]



**Connect-
ing meter-
ing pump**

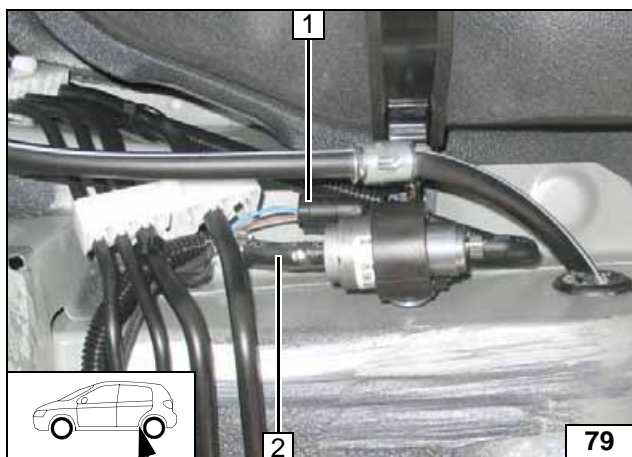

- 1 Wiring harness of metering pump, connector mounted
- 2 Fuel line, heater, hose section, 10 mm dia. clamp [2x]



**Connect-
ing meter-
ing pump**

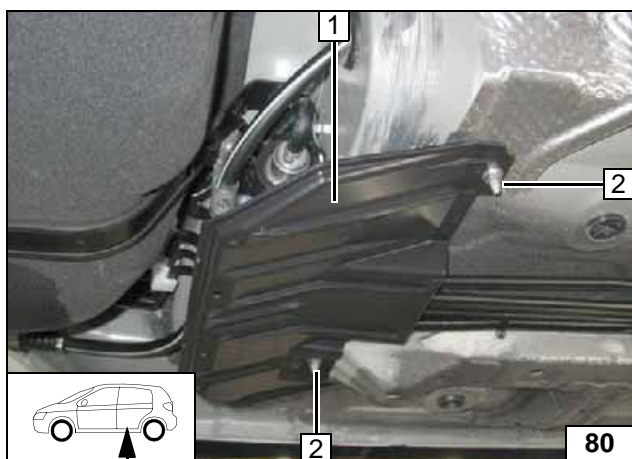

Check the position of the components; adjust if necessary. Check that they have freedom of movement.

- 1 Stoneguard
- 2 Original vehicle nut [2x]



**Installing
stoneguard**

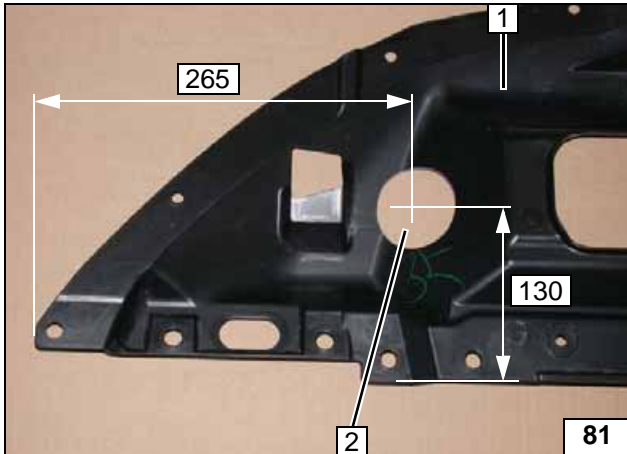

Underride Protection

- 1 Left underdrive protection
- 2 60 mm dia. hole



**Cutting out
underride
protection**

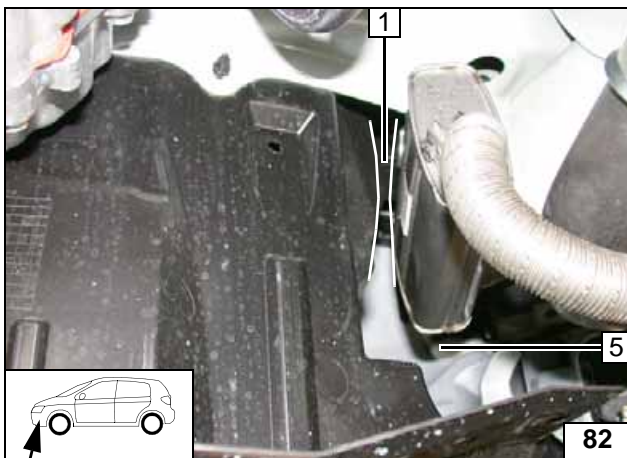

Ensure sufficient distance from adjacent components, especially with regard to the silencer at position 1, correct if necessary.



**Aligning si-
lencer**

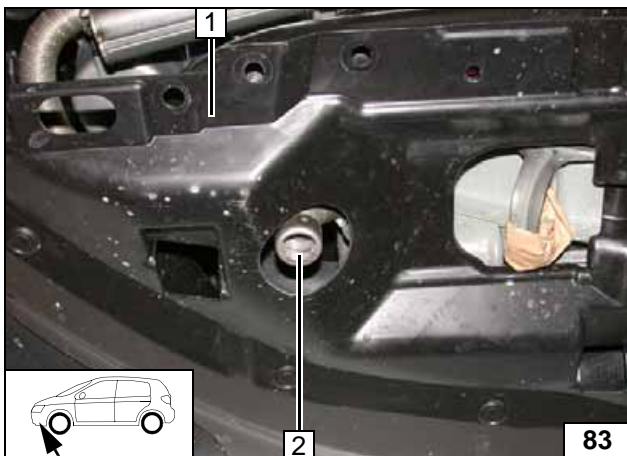

Centrally align exhaust end section 2 in hole. Ensure sufficient distance to neighbouring components; correct if necessary.



**Aligning
exhaust
end section**

- 1 Left underdrive protection



Final Work

WARNING!

Mount removed parts in reverse order. Check all hoses, clamps and all electrical connections for firm seating. Insulate all loose wires and tie back.

Only use manufacturer-approved coolant. Spray the heater components with anti-corrosion wax (Tectyl 100K, Order No. 111329).



- **Connect the battery.**
- **Fill and bleed the coolant circuit according to the vehicle manufacturer's specifications.**
- **Adjust digital timer, teach Telestart transmitter.**
- **Make settings on A/C control panel according to the "Operating Instructions for the End Customer".**
- **Place the "Switch off parking heater before refuelling" signboard in the area of the filler neck.**
- **For initial startup and function check, please see installation instructions.**



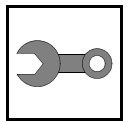

Template for Fuel Standpipe

X = flat length

without saddle tank = 220mm.
with saddle tank = 240mm.

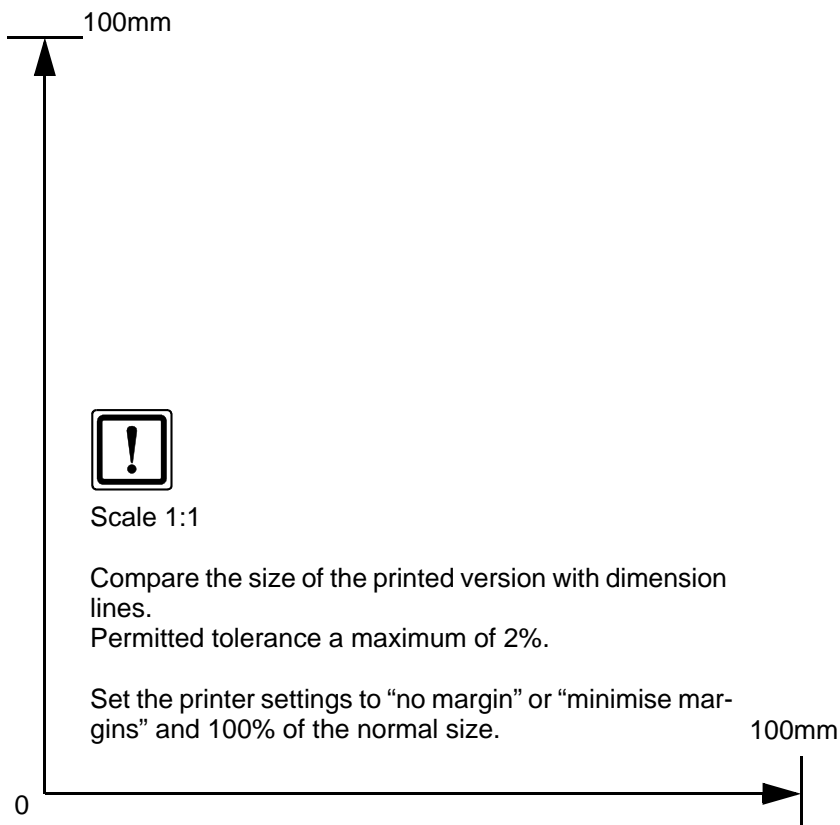
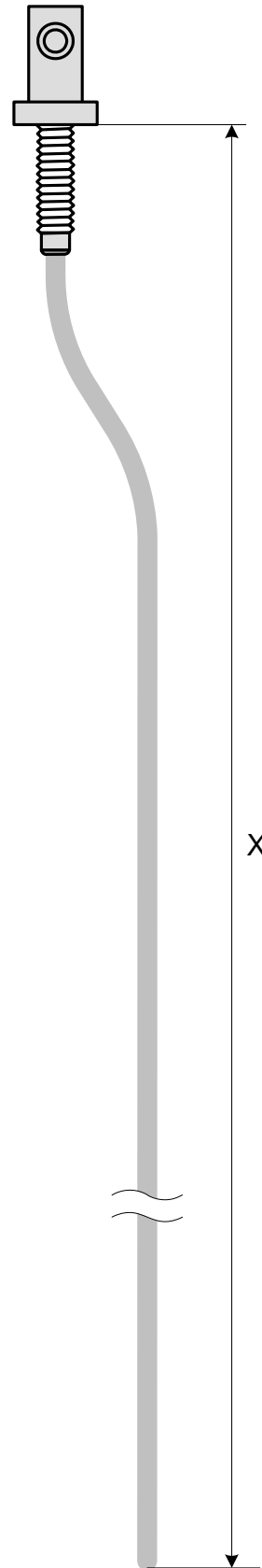

Operating Instructions for Manual Air-Conditioning

Please remove this page in case of manual air-conditioning and add it to the vehicle operating instructions.

Note:

We recommend matching the heating time to the driving time.
Heating time = driving time

Example:

For a driving time of approx. 20 min. (in one direction), we recommend not exceeding a switch-on time of 20 min.

Passenger compartment monitoring, if installed, must be deactivated in addition to the vehicle settings for the heating operation.

For instructions on deactivation, please refer to the operating instructions of the vehicle.

Before parking the vehicle, make the following settings:

- 1 Air outlet to windscreen
- 2 Set temperature to "max."



A/C control panel

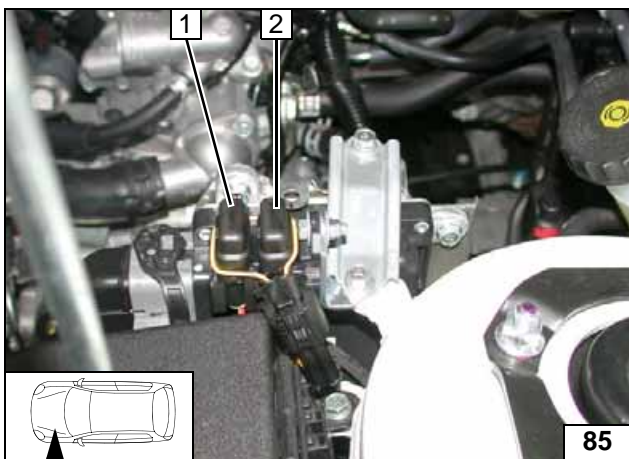

- 1 20A heater fuse F1
- 2 30A main fuse F2

Fuses of engine compartment

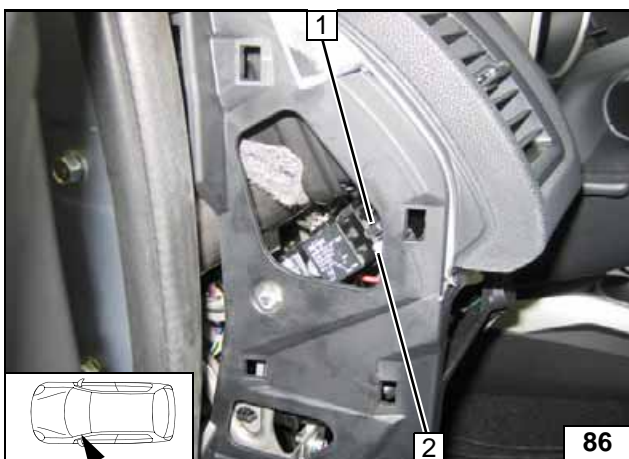

- 1 1A fuse heater control F3
- 2 25A fan fuse F4

Fuses of passenger compartment



Operating Instructions Automatic Air-Conditioning

Please remove this page in case of automatic air-conditioning and add it to the vehicle operating instructions.

Note:

We recommend matching the heating time to the driving time.

Heating time = driving time

Example:

For a driving time of approx. 20 min. (in one direction), we recommend not exceeding a switch-on time of 20 min.

Passenger compartment monitoring, if installed, must be deactivated in addition to the vehicle settings for the heating operation.

For instructions on deactivation, please refer to the operating instructions of the vehicle.

Before parking the vehicle, make the following settings:



- 1 Air outlet to windscreen
- 2 Set temperature to "max."

A/C control panel

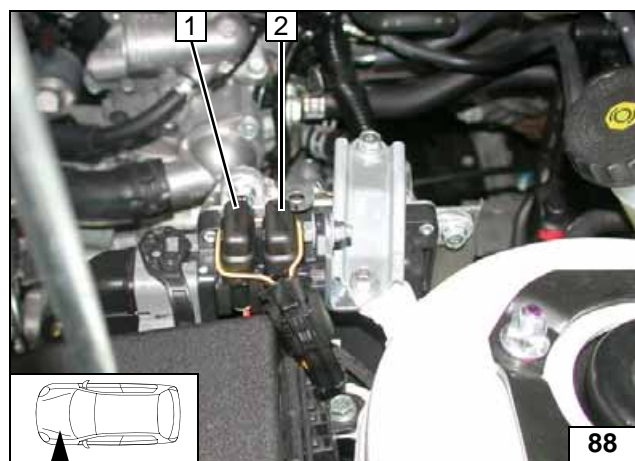

- 1 20A heater fuse F1
- 2 30A main fuse F2

Fuses of engine compartment

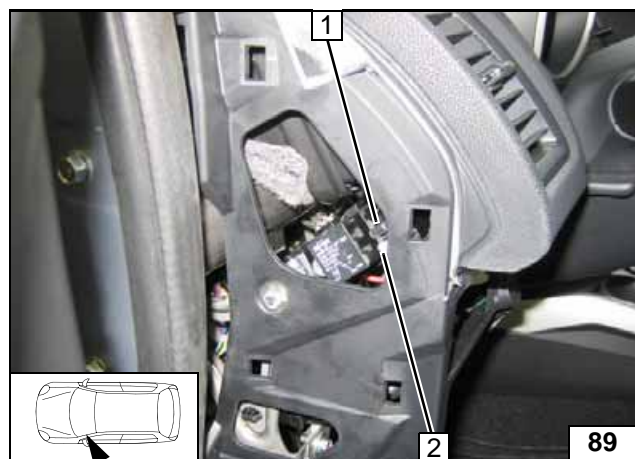

- 1 1A fuse heater control F3
- 2 25A fan fuse F4

Fuses of passenger compartment

