

Water Heater

Thermo Top Evo Parking Heater



Installation Documentation Citroen DS3

Validity

Manufacturer	Model	Type	EG-BE No. / ABE
Citroen	DS3	S	e2 * 2007 / 46 * 0003 * ...

Motorisation	Fuel	Transmission type	Output in kW	Displacement in cm ³	Engine code
1.2 VTi 82	Petrol	SG	60	1199	HM01
1.4 VTi 95	Petrol	SG	70	1397	8FP0
1.6 VTi 120	Petrol	SG	88	1598	5FS0
1.6 THP 150	Petrol	SG	115	1598	5FR8
1.6 HDI 90 FAP	Diesel	SG	68	1560	9HP0
1.6 HDI 90 FAP 99g	Diesel	SG	68	1560	9HP4
1.6 HDI 110 FAP	Diesel	SG	82	1560	9HR8

SG = Manual transmission

From Model Year 2010

Left-hand drive vehicle

Verified equipment variants: Manual / automatic air-conditioning system

Front fog lights

Total installation time: approx. 8 hours

Citroen DS3

Table of Contents

Validity	1	Preparing Heater	16
Necessary Components	2	Installing Heater	16
Installation Overview	2	Fuel	18
Information on Total Installation Time	2	VTi Coolant Circuit Diagram	22
Information on Operating and Installation Instructions	3	THP Coolant Circuit Diagram	23
Information on Validity	4	HDI Coolant Circuit Diagram	24
Technical Information	4	Preparing Coolant Circuit	25
Explanatory Notes on Document	4	VTi Hose Routing	27
Preliminary Work	5	THP Hose Routing	29
Heater Installation Location	5	HDI Hose Routing	31
Preparing Electrical System	6	Combustion Air	33
Electrical System	8	Exhaust Gas	34
Fan Controller for Manual Air-Conditioning	10	Final Work	36
Fan Controller for Automatic Air-Conditioning	11	Template for Petrol Fuel Standpipe	37
Digital Timer	14	Template for Diesel Fuel Standpipe	38
Remote Option (Telestart)	14	Operating Instructions for Manual Air-Conditioning	39
Preparing Installation Location	15	Operating Instructions Automatic Air-Conditioning	40

Necessary Components

- Basic delivery scope of *Thermo Top Evo* based on price list
- Installation kit for Citroen DS3 2010 Petrol and diesel: **1316207C**
- To be ordered additionally in case of automatic air-conditioning:
Additional kit for Citroen DS3 2010 automatic air-conditioning: **1316209A**
- Heater control in accordance with price list and upon consultation with end customer
- In case of Telestart, indicator lamp in accordance with price list and in consultation with end customer

Installation Overview

Legend:

1. Heater
2. Fuse holder of engine compartment
3. Passenger compartment relay and fuse holder
4. IPCU (only with automatic A/C)
5. K2 relay (only with automatic A/C)
6. Circulating pump
7. Digital Timer
8. Metering pump

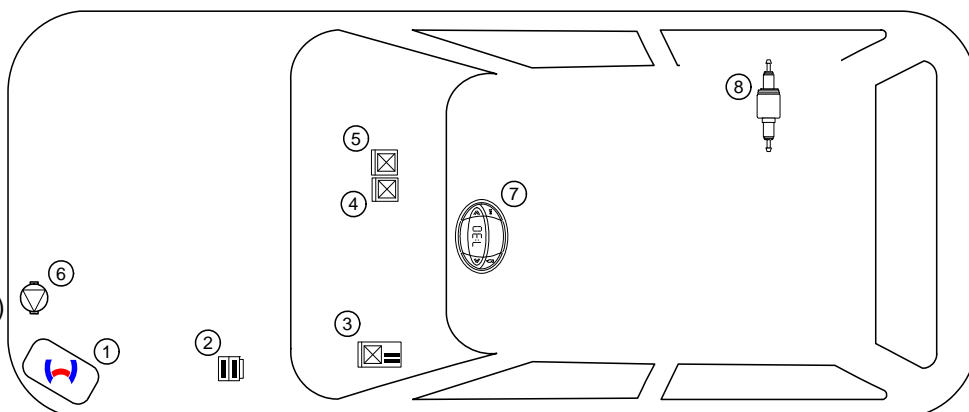

Information on Total Installation Time

The total installation time includes the time needed for mounting and demounting of the vehicle-specific components, the heater specific installation time and all other times required for the system integration and initial start-up of the heater.

The total installation time may vary for vehicle equipment other than provided.

Information on Operating and Installation Instructions

1 Important notes (not complete)

1.1 Installation and repair



The improper installation or repairing of Webasto heating and cooling systems can cause fire or the leakage of deadly carbon monoxide, leading to serious injury or death.



To install and repair Webasto heating and cooling systems you need to have completed a special company training course and have the appropriate technical documentation, special tools and special equipment.



Installation and repair may ONLY be carried out by persons trained and certified in a Webasto training course. NEVER try to install or repair Webasto heating or cooling systems if you have not completed a Webasto training course, you do not have the necessary technical skills and you do not have the technical documentation, tools and equipment available to ensure that you can complete the installation and repair work properly.

Only use genuine Webasto parts. See the Webasto air and water heaters accessories catalogue for this purpose.

1.2 Operation

To ensure safe operation, we recommend having the heater checked every two years by an authorised Webasto dealer, especially when used over a long period and/or under extreme environmental conditions.

Do not operate the heater in closed rooms due to the danger of poisoning and suffocation.

Always switch off the heater before refuelling.

The heater may only be used with the prescribed fuel Diesel (DIN EN 590) or petrol (DIN EN 227).

The heater may not be cleaned with a high-pressure cleaner.

1.3 Please note

ALWAYS follow all Webasto installation and operating instructions and observe all warnings.

To become familiar with and understand all functions and properties of the heater, the operating instructions must be read carefully and observed at all times.

For proper, safe installation and repair work, the installation instructions with all warnings and safety information must be carefully read and observed at all times. Please always contact a workshop authorised by Webasto for all installation and repair work.

Important

Webasto shall assume no liability for defects, damage and injuries resulting from a failure to observe the installation, repair and operating instructions of the information contained in them.

This liability exclusion particularly applies to improper installations and repairs, installations and repairs by untrained persons or in the case of a failure to use genuine spare parts.

The liability due to culpable disregard to life, limb or health and due to damage or injuries caused by a wilful or reckless breach of duty remain unaffected, as does the obligatory product liability.

Installation should be carried out according to the general, standard rules of technology. Unless specified otherwise, fasten hoses, wires and wiring harnesses to original vehicle lines and wiring harnesses using cable ties. Insulate loose wires and tie back. Connectors on electronic components have to audibly click into place during installation.

Sharp edges should be fitted with rub protection. Spray unfinished body areas, e.g. drilled holes, with anti-corrosion wax (Tectyl 100K, Order No. 111329).

Observe the instructions and guidelines of the respective vehicle manufacturer for demounting and mounting vehicle specific components!

The initial startup is to be executed with the Webasto Thermo Test Diagnosis.

When installing an IPCU, the corresponding settings must be checked or adjusted before the installation.

2 Statutory regulations governing installation

Guidelines	Thermo Top Evo
Heating Directive ECE R122	E1 00 0258
EMC Directive ECE R10	E1 03 5627

Note

The regulations of these guidelines are binding in the scope of the Directive 70/156/EEC and/or 2007/46/EC (for new vehicle models from 29/04/2009) and should also be observed in countries in which there are no special regulations.

Important

Failure to follow the installation instructions will result in the invalidation of the type approval for the heater and therefore invalidation of the general **homologation of the vehicle**.

Note

For vehicles with an EU permit, no entry in accordance with § 19 Sub-Section 4 of Annex VIII b to the Road Traffic Act is required.

2.1 Excerpt from the directive 2001/56/EC Appendix VII for the installation of the heater

Beginning of excerpt.

ANNEX VII

REQUIREMENTS FOR COMBUSTION HEATERS AND THEIR INSTALLATION

1. GENERAL REQUIREMENTS

1.7.1. A clearly visible tell-tale in the operator's field of view shall inform when the combustion heater is switched on or off.

2. VEHICLE INSTALLATION REQUIREMENTS

2.1. Scope

2.1.1. Subject to paragraph 2.1.2. combustion heaters shall be installed according to the requirements of this Annex.

2.1.2. Vehicles of category O having liquid fuel heaters are deemed to comply with the requirements of this Annex.

2.2. Positioning of heater

2.2.1. Body sections and any other components in the vicinity of the heater must be protected from excessive heat and the possibility of fuel or oil contamination.

2.2.2. The combustion heater shall not constitute a risk of fire, even in the case of overheating. This requirement shall be deemed to be fulfilled if the installation ensures an adequate distance to all parts and suitable ventilation, by the use of fire resistant materials or by the use of heat shields.

2.2.3. In the case of M2 and M3 vehicles, the heater must not be positioned in the passenger compartment. However, an installation in an effectively sealed envelope which also complies with the conditions in paragraph 2.2.2 may be used.

2.2.4. The label referred to in paragraph 1.4 or a duplicate, must be positioned so that it can be easily read when the heater is installed in the vehicle.

2.2.5. Every reasonable precaution should be taken in positioning the heater to minimise the risk of injury and damage to personal property.

2.3. Fuel supply

2.3.1. The fuel filler must not be situated in the passenger compartment and must be provided with an effective cap to prevent fuel spillage

2.3.2. In the case of liquid fuel heaters, where a supply separate to that of the vehicle is provided, the type of fuel and its filler point must be clearly labelled

2.3.3. A notice, indicating that the heater must be shut down before refuelling, must be affixed to the fuelling point. In addition a suitable instruction must be included in the manufacturer's operating manual.

2.4. Exhaust system

2.4.1. The exhaust outlet must be located so as to prevent emissions from entering the vehicle through ventilators, heated air inlets or opening windows.

2.5. Combustion air inlet

2.5.1. The air for the combustion chamber of the heater must not be drawn from the passenger compartment of the vehicle.

2.5.2. The air inlet must be so positioned or guarded that blocking by rubbish or luggage is unlikely.

2.6. Heating air inlet

2.6.1. The heating air supply may be fresh or recirculated air and must be drawn from a clean area not likely to be contaminated by exhaust fumes emitted either by the propulsion engine, the combustion heater or any other vehicle source.

2.6.2. The inlet duct must be protected by mesh or other suitable means.

2.7. Heating air outlet

2.7.1. Any ducting used to route the hot air through the vehicle must be so positioned or protected that no injury or damage could be caused if it were to be touched.

2.7.2. The air outlet must be so positioned or guarded that blocking by rubbish or luggage is unlikely.

End of excerpt.

In multilingual versions the German language is binding.

Information on Validity

This installation documentation applies to Citroen DS3 Petrol and diesel vehicles - for validity, see page 1 - from model year 2010 and later, assuming technical modifications to the vehicle do not affect installation, any liability claims excluded. Depending on the vehicle version and equipment, modifications may be necessary during installation with respect to these "installation instructions".

Vehicle and engine types, equipment variants and other specifications not listed in this installation documentation have not been tested. However, installation according to this installation documentation may be possible.

Technical Information

Special Tools

- Hose clamp pliers for auto-tightening hose clamps
- Hose clamp pliers for Clic hose clamps of type W
- Automatic wire stripper 0.2 - 6mm²
- Crimping pliers for cable lug / tab connector 0.5 - 6mm²
- Torque wrench for 2.0 - 10 Nm
- Hose clamping pliers
- Metric thread-setter kit
- Webasto Thermo Test Diagnosis with current software

Dimensions

- All dimensions in mm.

Tightening torque values

- Tightening torque values for 5x13 heater bolts and 5x11 heater stud bolts = 8Nm.
- Tightening torque values of 5x15 retaining plate of water connection piece bolts = 7Nm.
- Tighten other bolt connections in accordance with manufacturer's instructions or in accordance with state-of-the-art-technology.

Explanatory Notes on Document

You will find an identification mark on the outside top right corner of the page in question to provide you with a quick overview of the individual working steps.

Special features are highlighted using the following symbols:

Mechanical system



Electrical System



Coolant Circuit

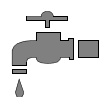

Combustion Air



Fuel



Exhaust gas



Software



Special risk of injury or fatal accidents.



Specific risk of damage to components.



Specific risk of fire or explosion.



Reference to general installation instructions of the Webasto component or to vehicle specific documents of the manufacturer



Reference to a special technical feature.



The arrow in the vehicle icon indicates the position on the vehicle and the viewing angle.

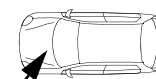

Citroen DS3

Preliminary Work

Vehicle

- Open the fuel tank cap.
- Ventilate the fuel tank.
- Close the fuel tank cap again.
- Depressurise the cooling system.
- Disconnect and completely remove the battery with carrier.
- Detach the control unit and put it aside.
- Remove the air filter together with the intake hose.
- Remove the charge air tube.
- Detach the wheel well trim on the right and left.
- Remove the bumper trim.
- Remove the left-hand headlight.
- Remove the front underride protection.
- Fold the rear bench seat.
- Open the right-hand tank-fitting service lid.
- Remove the fuel-tank sending unit in accordance with the manufacturer's instructions.
- Remove the instrument panel trim in the footwell on the driver's side.
- Detach the central switching unit (BSI) on the driver's side and lay it aside.
- Remove the instrument panel trim on the left (only with Telestart T100 HTM).
- Remove the radio / A/C control panel according to the manufacturer's instructions (only with automatic A/C).

Heater

- Remove years that do not apply from the type and duplicate label.
- Attach the duplicate label (type label) in the appropriate place in the engine compartment.

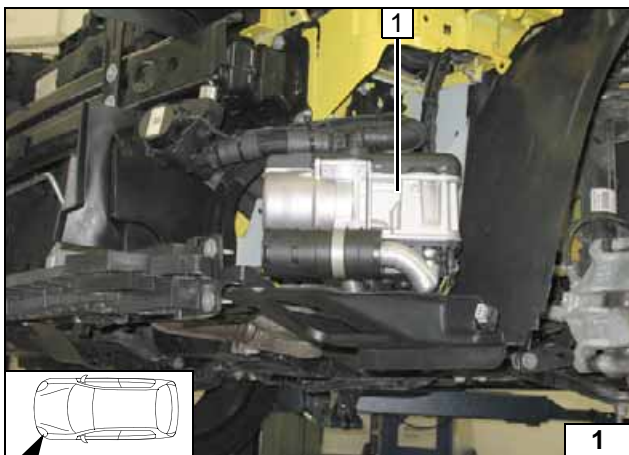

Heater Installation Location

1 Heater

Installation location

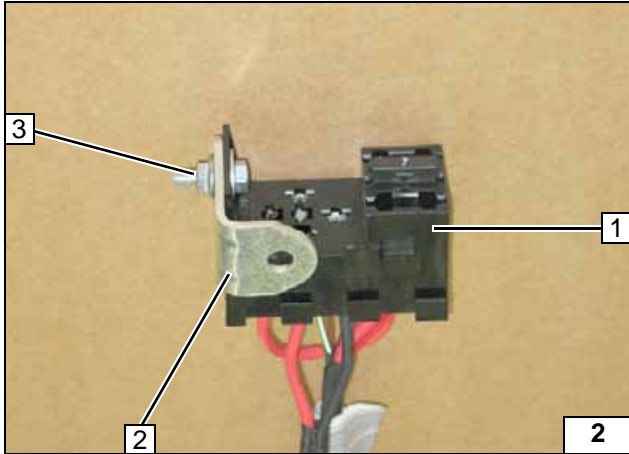
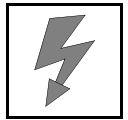

Preparing Electrical System

Wire sections retain their numbering throughout the entire document.

Manual air-conditioning

25A F4 and K1 relay are inserted in passenger compartment relay and fuse holder after installation.

- 1 Relay and fuse holder of passenger compartment
- 2 Angle bracket
- 3 M5x16 bolt, large diameter washer, flanged nut



Preparing passenger compartment relay and fuse holder

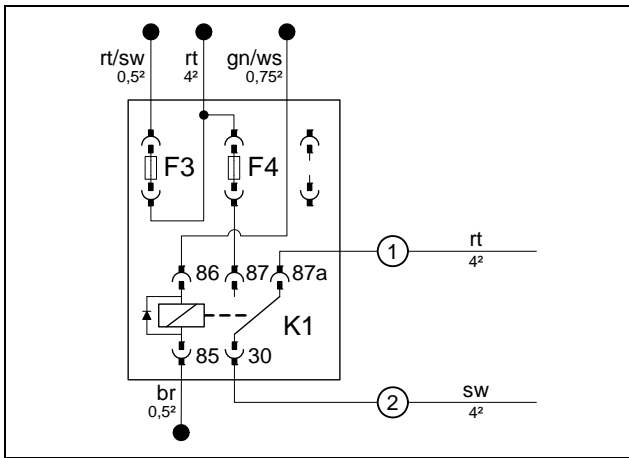

Install wires according to the wiring diagram.



Preparing passenger compartment relay and fuse holder

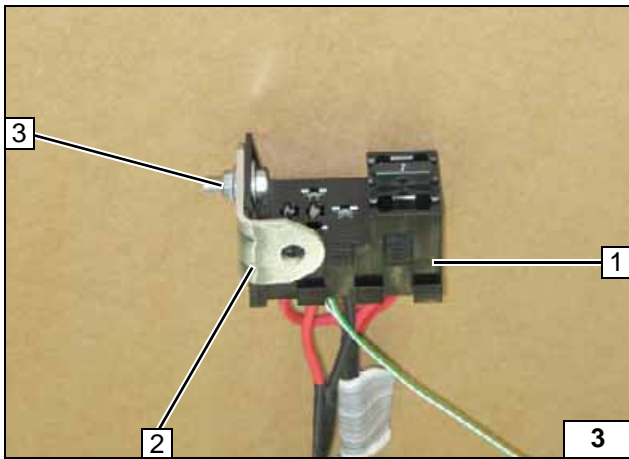

Automatic air-conditioning

25A F4 and K1 relay are inserted in passenger compartment relay and fuse holder after installation.

Detach/remove K1/86 contact. Install wires as shown in following wiring diagram with contacts supplied.

- 1 Relay and fuse holder of passenger compartment
- 2 Angle bracket
- 3 M5x16 bolt, large diameter washer, flanged nut



Preparing passenger compartment relay and fuse holder

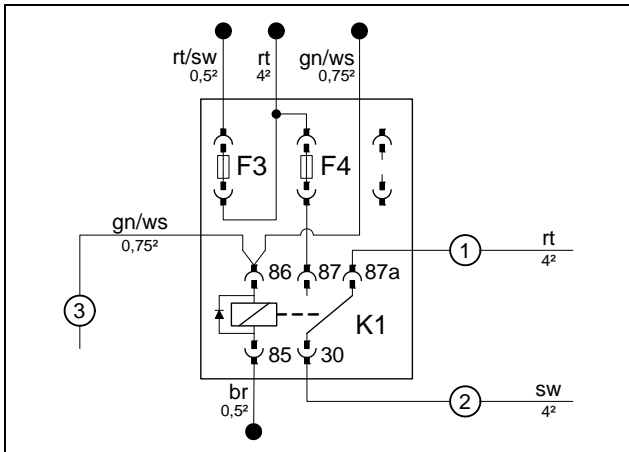

Cut off 1700mm from protective sleeving and insert green/white (gn/ws) wire ③.



Preparing passenger compartment relay and fuse holder

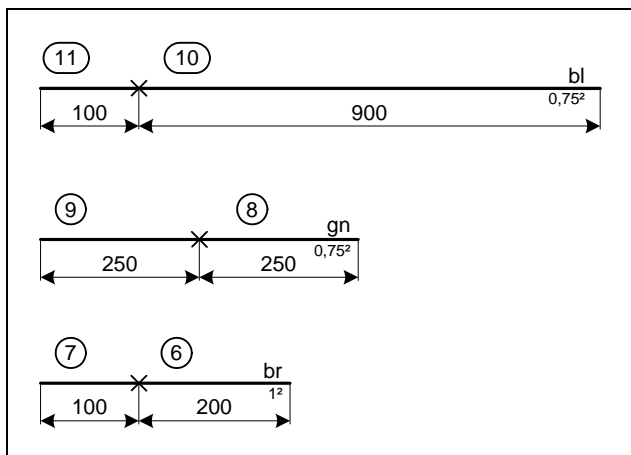
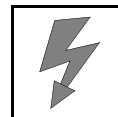

Cutting wires to length

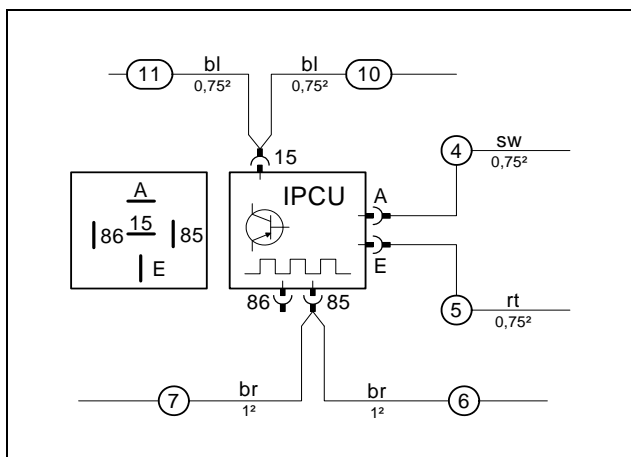

Connect lines to IPCU socket.
 IPCU view on contact side.
 Check the IPCU settings before start-up of the heater and adjust if necessary.

IPCU settings:

- Duty cycle: 27%
- Frequency: 400Hz
- Voltage: 10V
- Function: Low-side

Premounting IPCU

Pull wire section ⑩ into 800 mm protective sleeving.

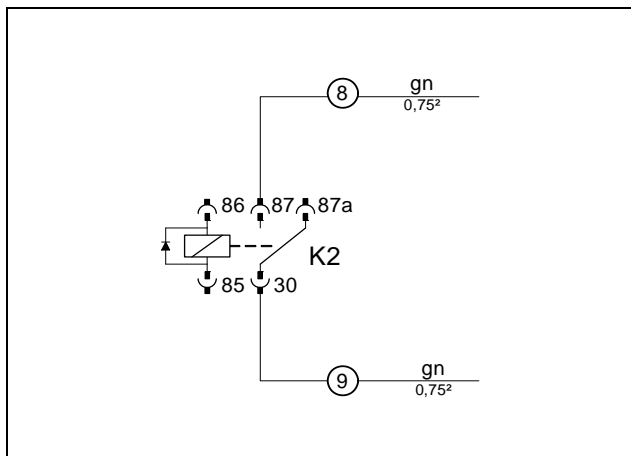

Preparing K2 additional relay

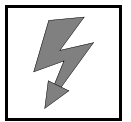

Electrical System

Positive and earth wire

- 1 Positive wire on original vehicle positive support point
- 2 Earth wire on original vehicle earth support point

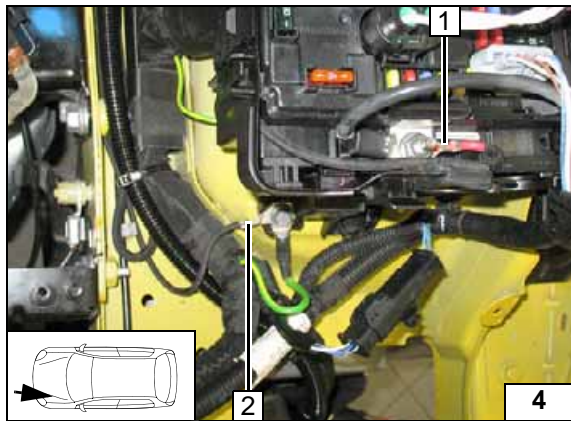

Fuse holder of engine compartment

- 1 M5x16 bolt, large diameter washer, retaining plate of fuse holder, flanged nut
- 2 Angle bracket
- 3 Retaining clip removed, M6x20 bolt, large diameter washer, flanged nut
- 4 F1-2 fuses mounted

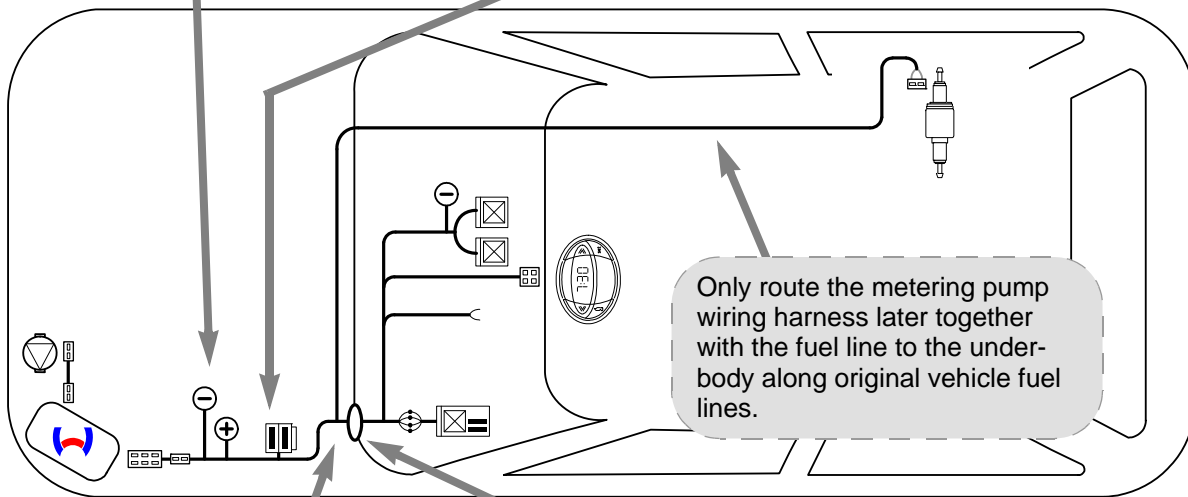
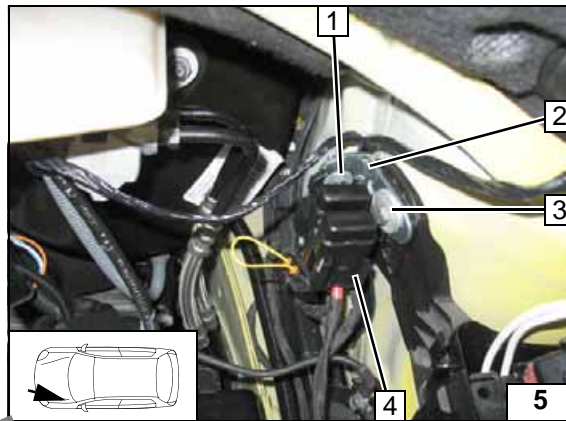

Wiring harness routing diagram

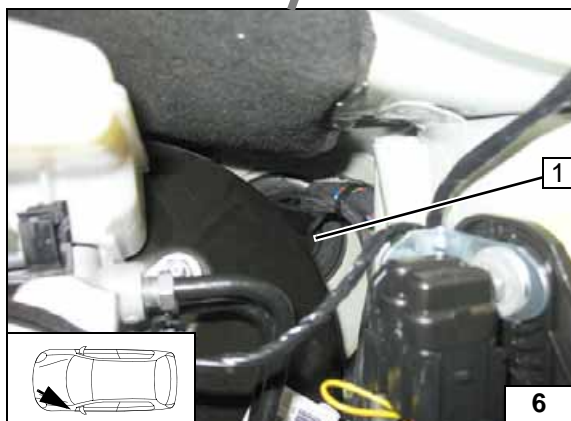

Wiring harness pass through to engine compartment

- 1 Protective rubber plug

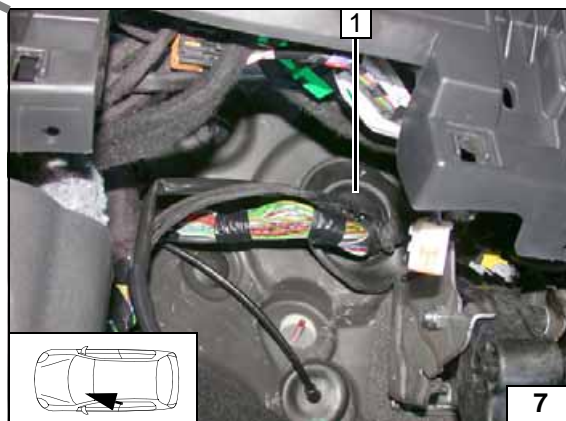

Wiring harness pass through of passenger compartment

- 1 Protective rubber plug

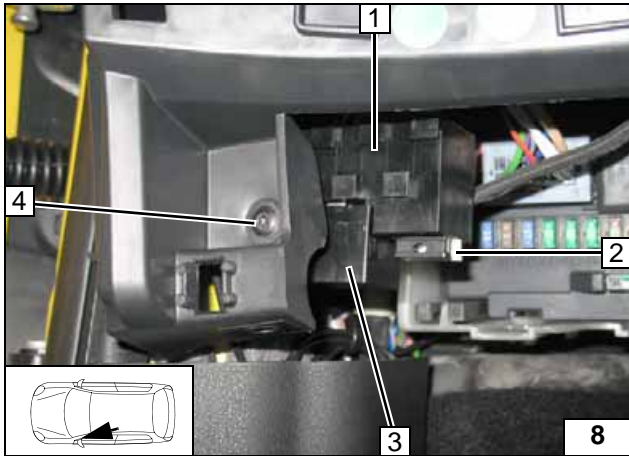

Install angle bracket on bolt 4 .

- 1 Relay and fuse holder of passenger compartment
- 2 F4 fuse inserted
- 3 K1 relay mounted



Mounting passenger compartment relay and fuse holder

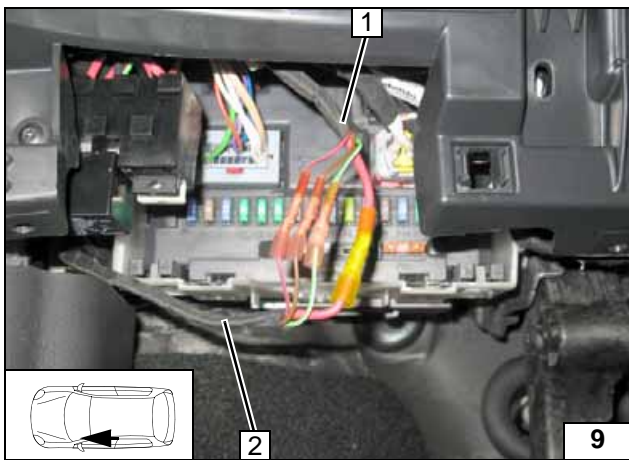

Connect wiring harnesses of engine compartment fuse holder 1 and passenger compartment relay and fuse holder 2 according to wiring diagram, so that the wires of the same colour are connected.



Connecting wiring harness of heater

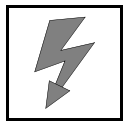

Fan Controller for Manual Air-Conditioning

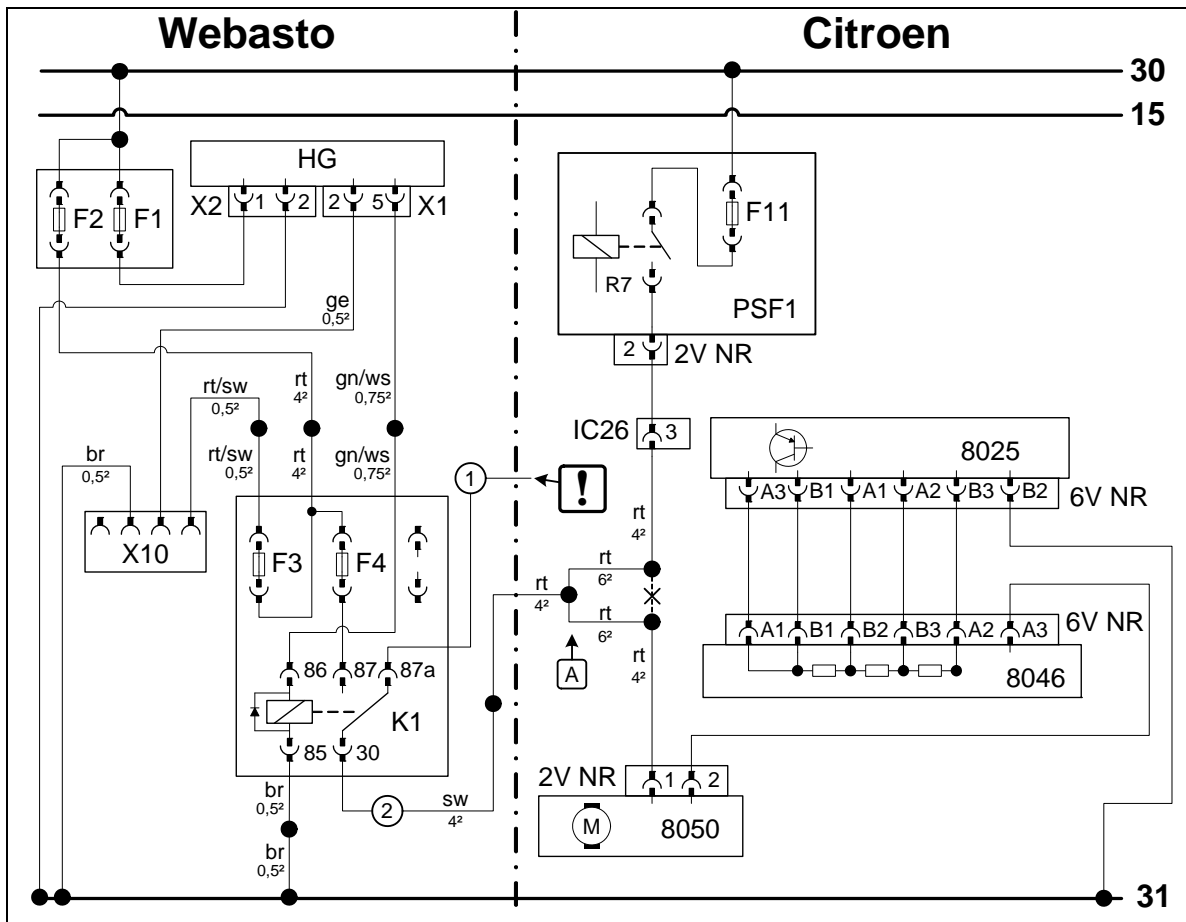

Wiring diagram

Webasto components		Vehicle components		Colours and symbols	
HG	TT-Evo heater	PSF1	Engine compartment fuse box	rt	red
X1	6-pin heater connector	F11	Fuse	ws	white
X2	2-pin heater connector	IC26	6-pin connector	sw	black
X10	4-pin connector Heater control	8025	A/C control panel	br	brown
K1	Fan relay	8046	Fan switch	gn	green
F1	20A fuse	8050	Fan motor	ge	yellow
F2	30A fuse			!	Insulate wire end and tie back
F3	1A fuse				
F4	25A fuse			X	Cutting point
A	Output adapter			Wiring colours may vary.	

Legend

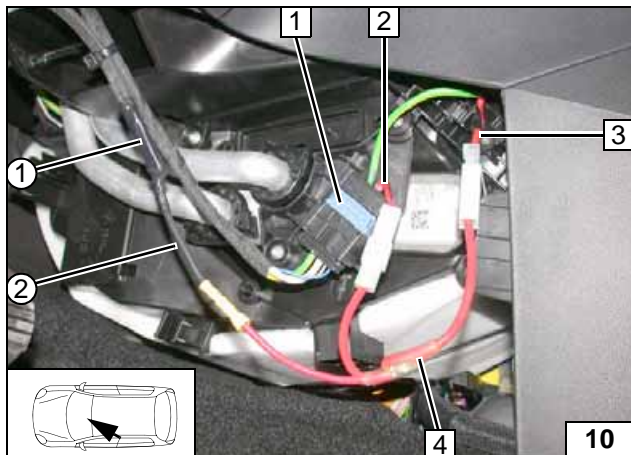

Connection on 6-pin connector IC26 1. Insulate red (rt) wire ① of K1/87a and tie back. Produce connections as shown in wiring diagram.

- 2 Red (rt) wire of connector IC26, pin 3
- 3 Red (rt) wire of fan motor
- 4 Output adapter
- ② Black (sw) wire from K1/30



Connecting fan motor

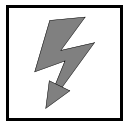

Fan Controller for Automatic Air-Conditioning

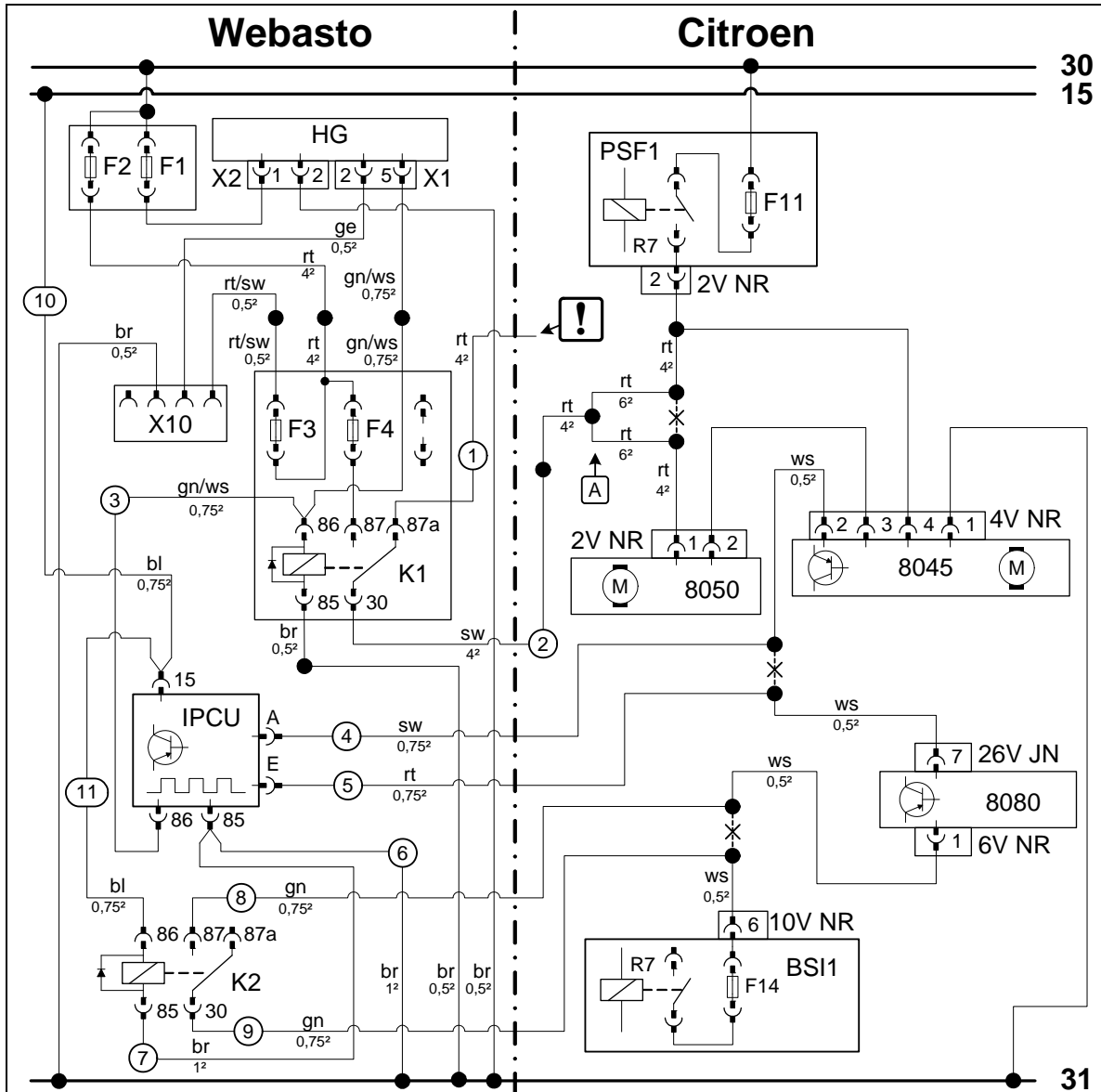

Wiring diagram

Webasto components		Vehicle components		Colours and symbols	
HG	TT-Evo heater	PSF1	Engine compartment fuse box	rt	red
X1	6-pin heater connector	F11	Fuse	ws	white
X2	2-pin heater connector	8045	Fan controller	sw	black
X10	4-pin connector of heater control	8050	Fan motor	br	brown
K1	Fan relay	8080	A/C control panel	bl	blue
K2	Additional relay	BSI1	Central switching unit	gn	green
F1	20A fuse			ge	yellow
F2	30A fuse				
F3	1A fuse				
F4	25A fuse				
A	Output adapter				
IPCU	Pulse width modulator				
IPCU settings:					
Duty cycle: 27%					Insulate wire end and tie back
Frequency: 400Hz					
Voltage: 10V					
Function: Low-side					
				X	Cutting point
				Wiring colours may vary.	

Legend

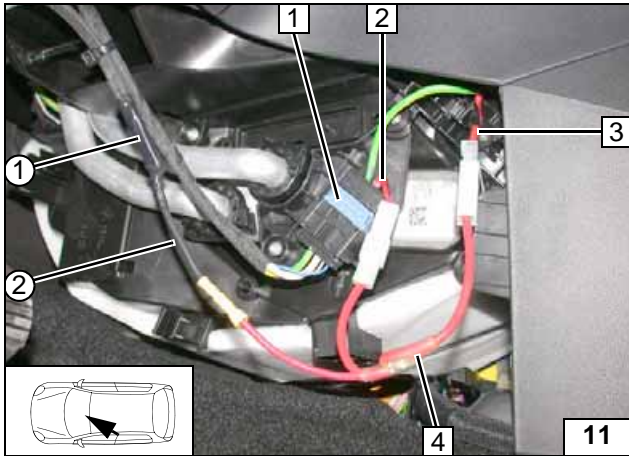
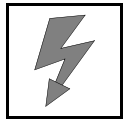

Connection on 6-pin connector IC26 1.
 Insulate red (rt) wire ① of K1/87a and tie back.
 Produce connections as shown in wiring diagram.

- 2 Red (rt) wire of connector IC26, pin 3
- 3 Red (rt) wire of fan motor
- 4 Output adapter
- ② Black (sw) wire from K1/30



**Connect-
ing fan mo-
tor**

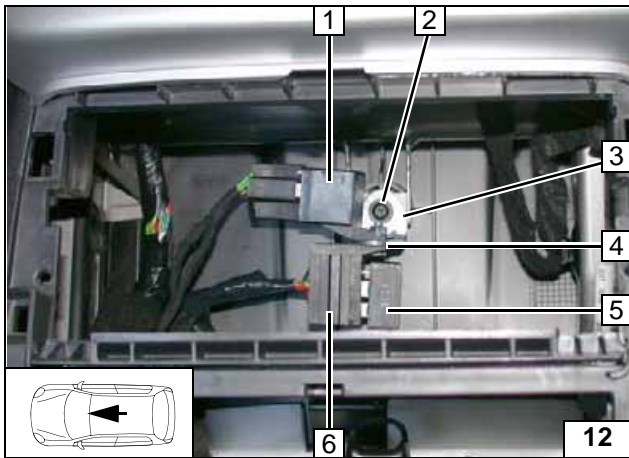

Insert green/white (gn/ws) wire ③ in IPCU/86 socket. Insert blue (bl) wire ⑪ in socket of K2/86 and brown (br) wire ⑦ in socket of K2/85. Produce connections as shown in wiring diagram.

- 1 K2 relay
- 2 Original vehicle bolt
- 3 Angle bracket
- 4 M5x16 bolt, large diameter washer, flanged nut
- 5 IPCU mounted
- 6 IPCU socket



**Installing
additional
relay K2
and IPCU**

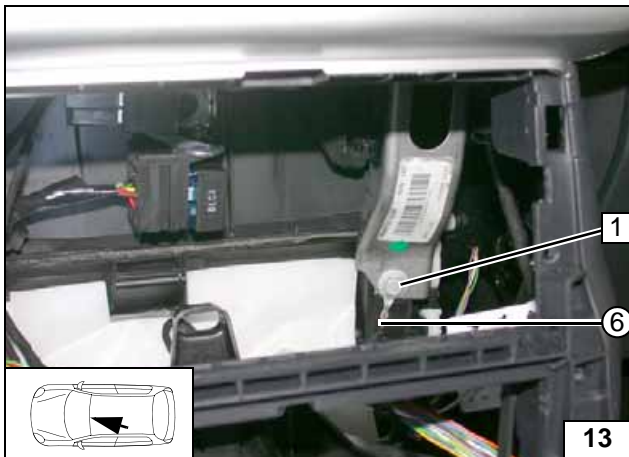

Produce connections as shown in wiring diagram.

- 1 Original vehicle bolt
- ⑥ Brown (br) wire from IPCU/85



**Earth con-
nection of
additional
relay K2
and IPCU**

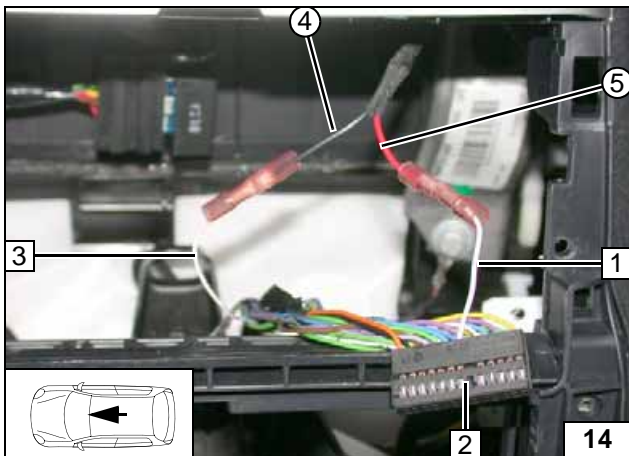

Connection on 26-pin connector 2 from A/C control panel 8080. Produce connections as shown in wiring diagram.

- 1 White (ws) wire 26-pin connector pin 7
- 3 White (ws) wire of fan controller
- ④ Black (sw) wire from IPCU/A
- ⑤ Red (rt) wire from IPCU/E



**Connect-
ing IPCU**

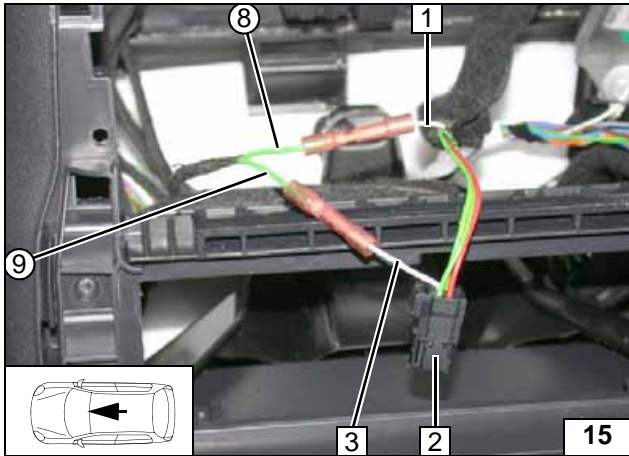
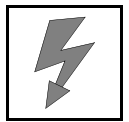

Connection on 6-pin connector **2** from A/C control panel 8080.
Produce connections as shown in wiring diagram.

- 1 White (ws) wire of BSI
- 3 White (ws) wire of 6-pin connector Pin1
- ⑧ Green (gn) wire from K2/87
- ⑨ Green (gn) wire from K2/30



**Connect-
ing addi-
tional relay
K2**

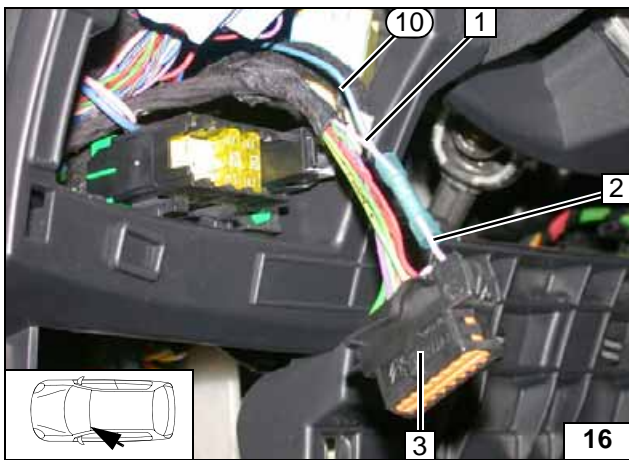

Connection on 16-pin OBD connector **3**.
Produce connections as shown in wiring diagram.

- 1 White (ws) wire of Terminal 15
- 2 White (ws) wire of 16-pin connector Pin1
- ⑩ Blue (bl) wire of IPCU/15



**Connec-
tion of
IPCU Ter-
minal 15**



Digital Timer

1 Digital timer



Installing digital timer

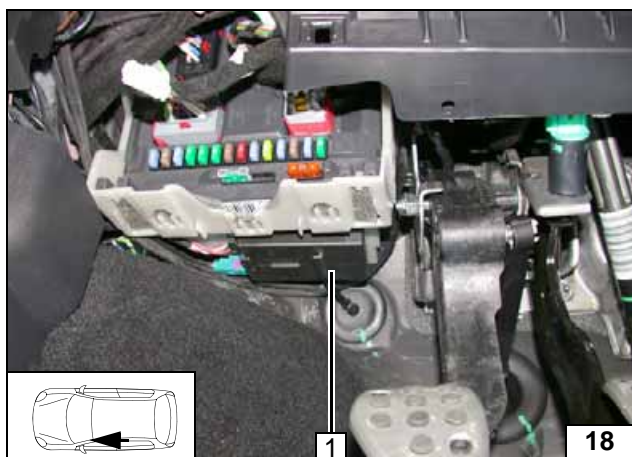

Remote Option (Telestart)

Fasten receiver 1 with adhesive tape.



Installing receiver

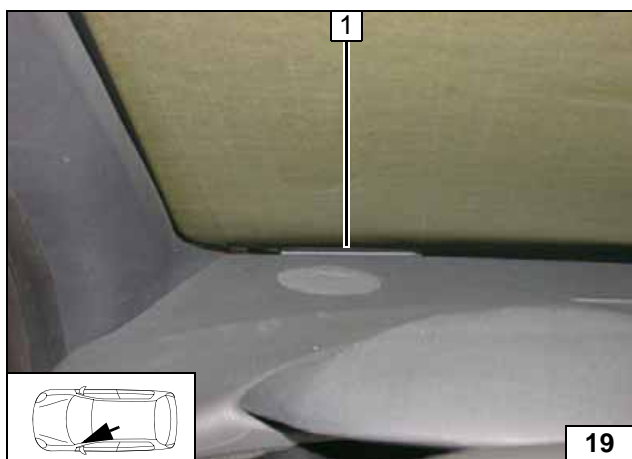

1 Antenna

Installing antenna

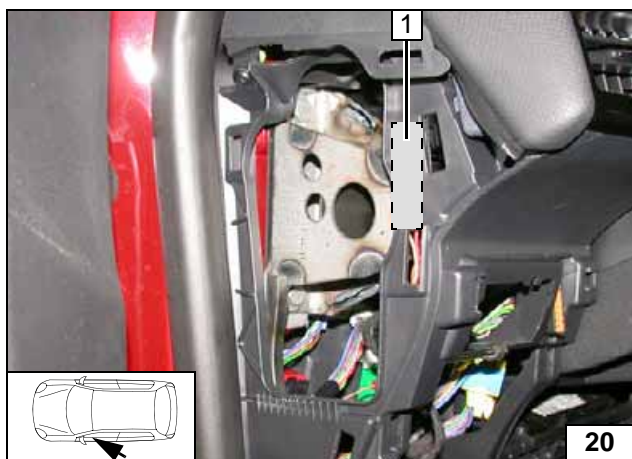

Temperature sensor T100 HTM

Fasten temperature sensor 1 behind instrument panel trim at left with adhesive tape.



Installing temperature sensor

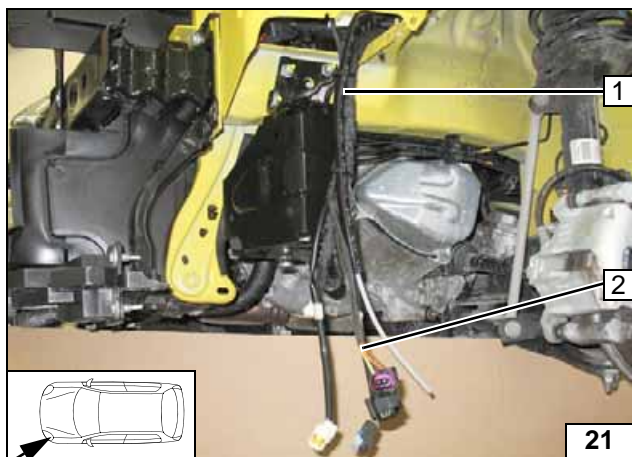

Preparing Installation Location

Route wiring harness of heater 2 to installation location. Pull fuel line into corrugated tube 1 and route to the firewall along the frame side member.



Preparing installation location

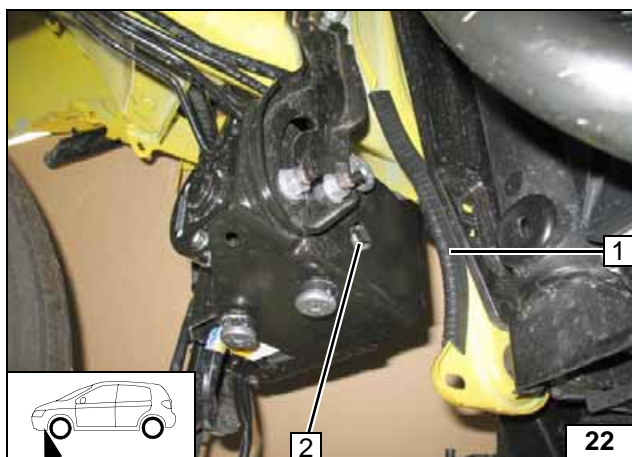

- 1 200 mm edge protection
- 2 Bend tab

Installing edge protection

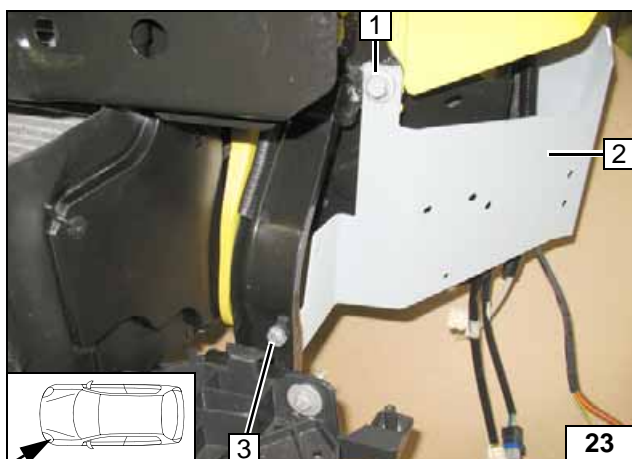

- 1 Original vehicle bolt
- 2 Install bracket loosely
- 3 M8x20 bolt, large diameter washer, flanged nut, existing hole



Installing bracket loosely

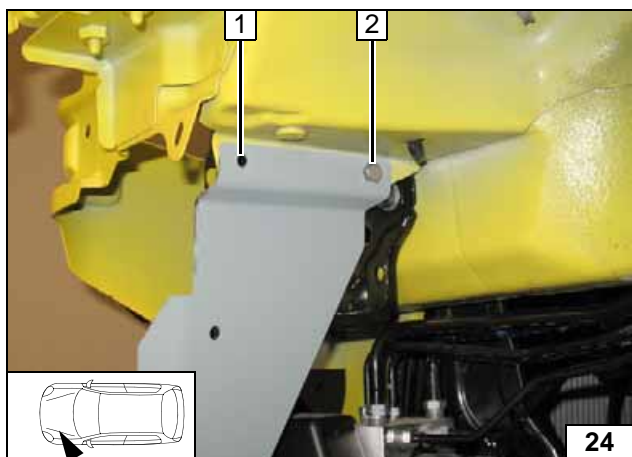

After copying hole pattern at position 1 , remove bracket.

- 1 7 mm dia. hole
- 2 M6x20 bolt, flanged nut, existing hole



Copying hole pattern

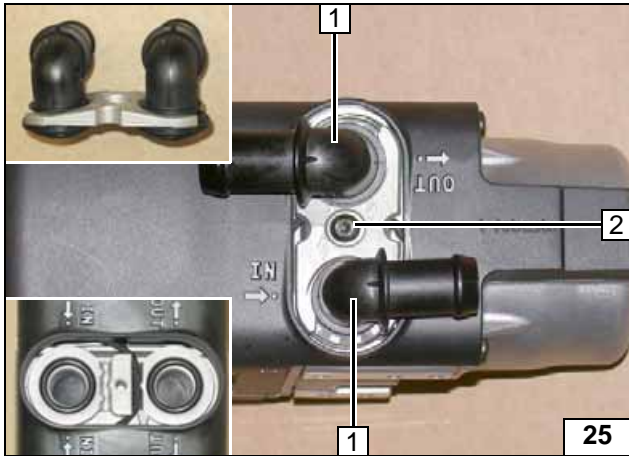

Preparing Heater

- 1 Water connection piece, sealing ring [2x each]
- 2 5x15 self-tapping bolt, retaining plate of water connection pieces

Installing water connection pieces

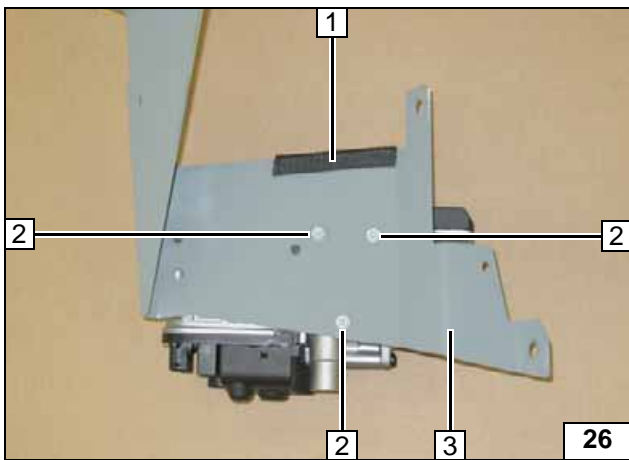

- 1 80 mm edge protection
- 2 5x13 self-tapping bolt [3x]
- 3 Install bracket loosely

Premounting heater

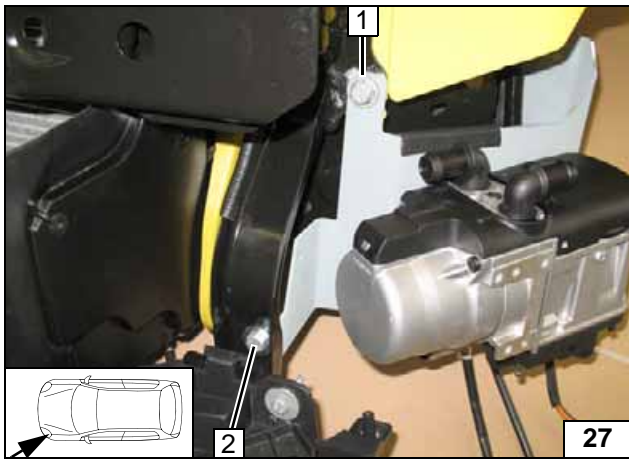

Installing Heater

- 1 Original vehicle bolt
- 2 M8x20 bolt, large diameter washer, flanged nut, existing hole

Installing heater

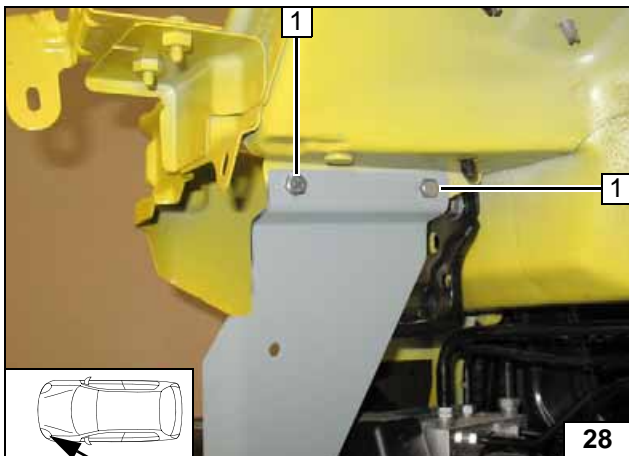

- 1 M6x20 bolt, flanged nut [2x each]

Installing heater

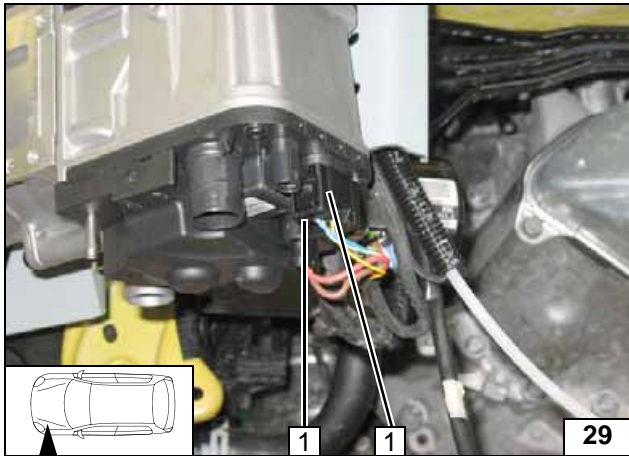

1 Wiring harness of heater [2x]

Installing wiring harness

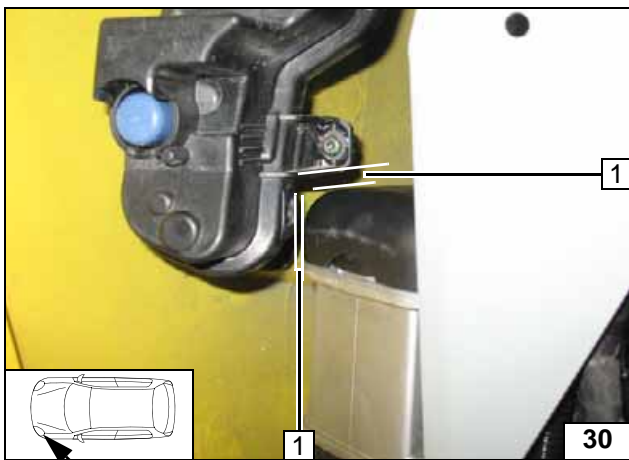

Install bumper on trial basis. Align heater, adjust distance from daytime running light 1. Check that they have freedom of movement. Tighten 5x15 bolt [3x] on heater. Remove bumper again.



Installing heater

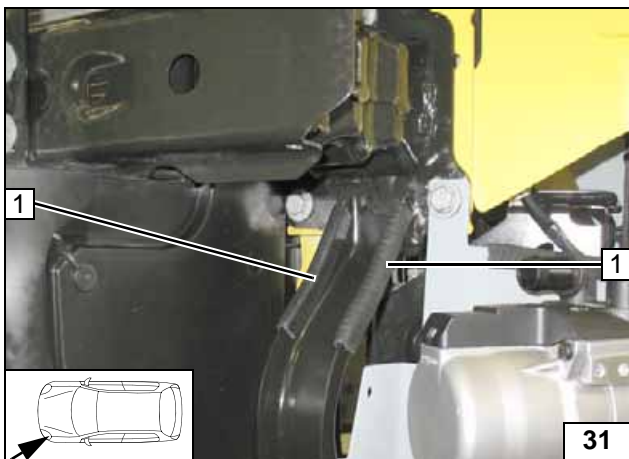

1 90mm edge protection [2x]

Installing edge protection

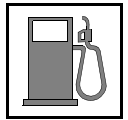

Fuel

CAUTION!

Open the vehicle's fuel tank cap, ventilate the tank and then re-close the tank lock.

Catch any fuel running off in an appropriate container.

Install fuel line and metering pump wiring harness so that they are protected against stone impact. Unless specified otherwise, always fasten using cable ties.
Mount the fuel line and wiring harness with rub protection on sharp edges.

WARNING!

The fuel line and wiring harness are routed to the metering pump as shown in the wiring harness routing diagram.

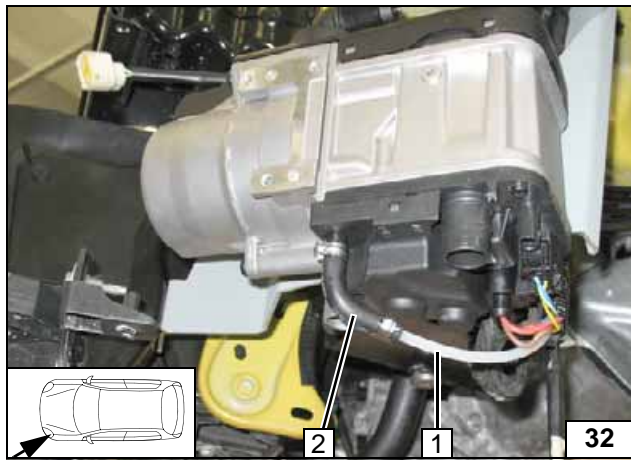

All vehicles

- 1 Fuel line
- 2 90° moulded hose, 10mm dia. clamp [2x]

**Connect-
ing heater**



Route fuel line and wiring harness of metering pump into corrugated tube 1 to the fire-wall.



**Routing
line**

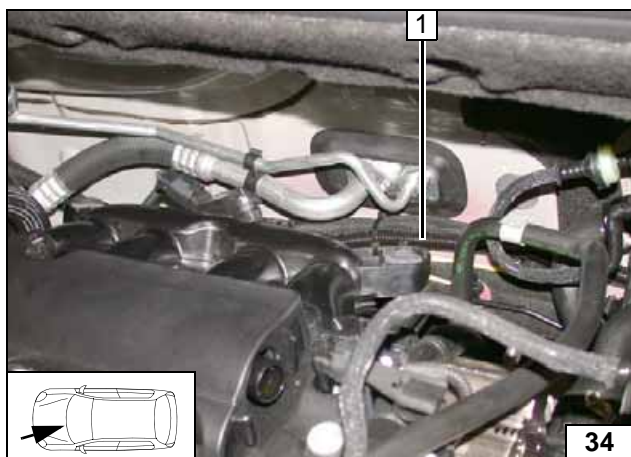

Route fuel line and wiring harness of metering pump in corrugated tube 1 on the right vehicle side and further to the underbody.



**Routing
lines**

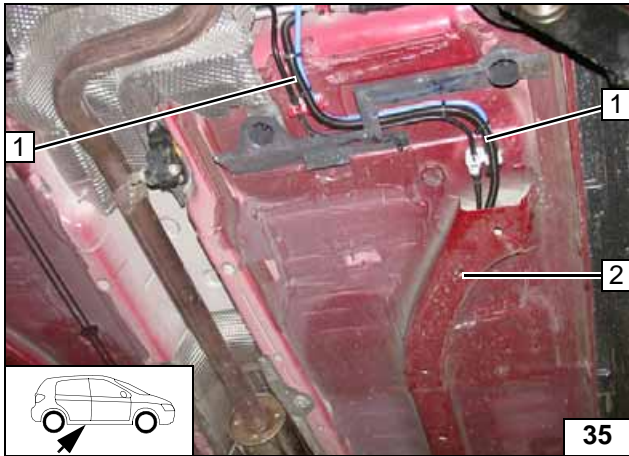
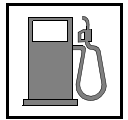

Route fuel line and wiring harness of metering pump in cable duct **2** along original vehicle lines to installation location of metering pump.



- 1 Fuel line and wiring harness of metering pump in corrugated tube

Routing lines

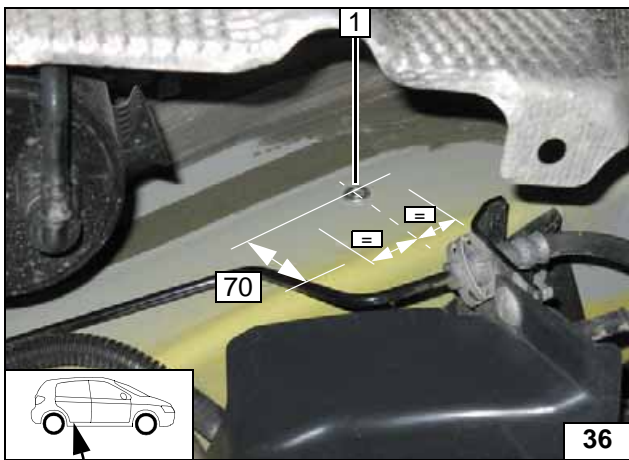

Drill 9.1mm hole at position **1** centrally between the welding points.



- 1 Rivet nut

Installing rivet nut

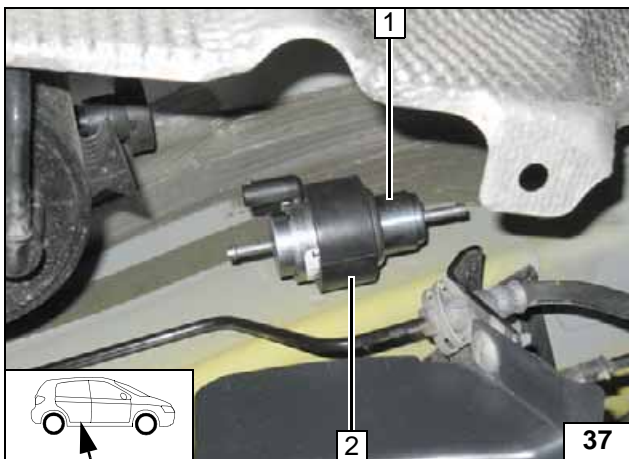

Install metering pump mounting **2** on rivet nut with M6x25 bolt and support angle bracket.



- 1 Metering pump

Mounting metering pump

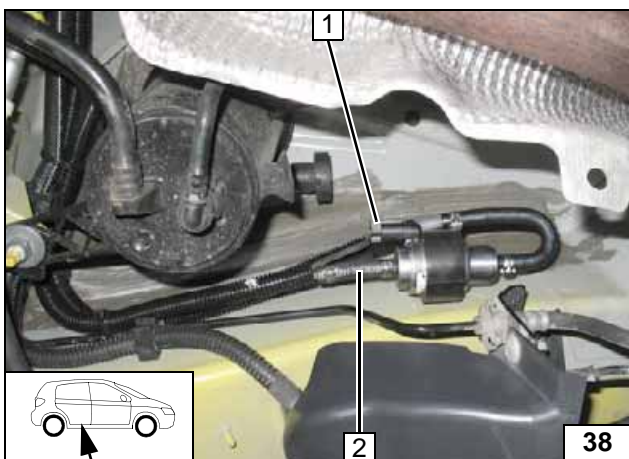

- 1 Wiring harness of metering pump, connector mounted
- 2 Fuel line of heater, hose section, 10mm dia. clamp [2x]



Connecting metering pump

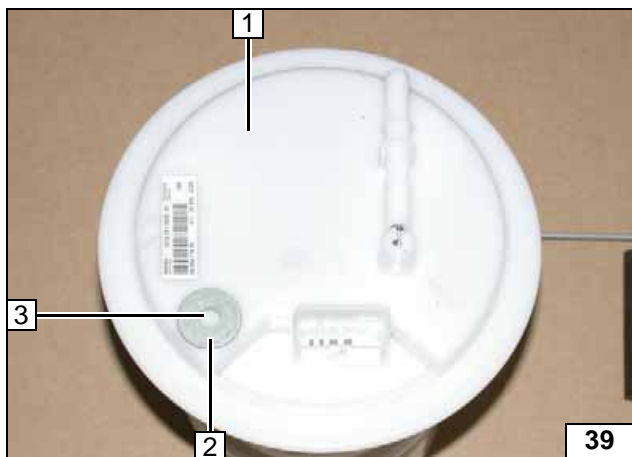
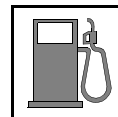

Fuel extraction, petrol

Remove fuel-tank sending unit **1** in accordance with the manufacturer's instructions.

- 2** Large diameter washer outer dia. = 21.6mm
- 3** Copy hole pattern, 6mm dia. hole



Fuel extraction



Shape fuel standpipe **1** as shown in the template and cut it to length.



Installing fuel standpipe

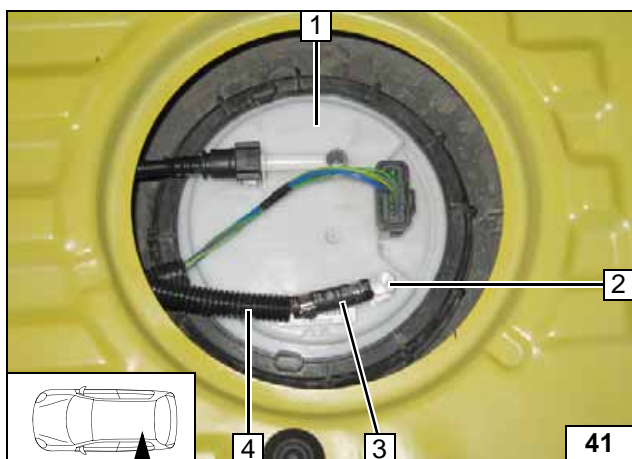

Install fuel-tank sending unit **1** in accordance with the manufacturer's instructions. Slide corrugated tube **4** onto fuel line.

- 2** Fuel standpipe
- 3** Hose section, 10mm dia.clamp [2x]



Connecting fuel line

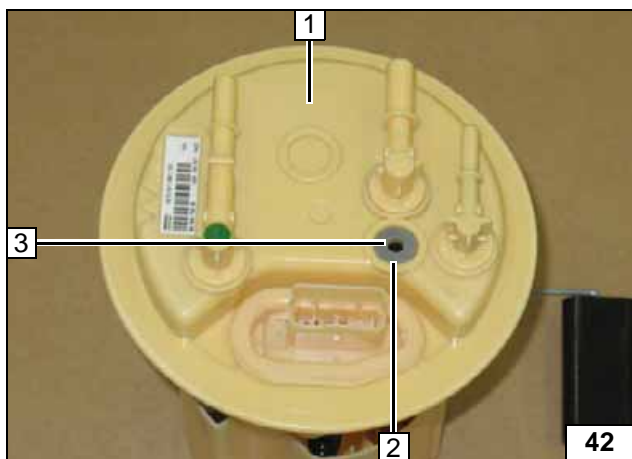

Fuel extraction, diesel

Remove fuel-tank sending unit **1** in accordance with the manufacturer's instructions.

- 2** Large diameter washer outer dia. = 14.6mm
- 3** Copy hole pattern, 6mm dia. hole



Fuel extraction

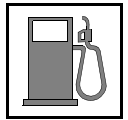

Installing fuel stand-pipe



**Connect-
ing fuel line**



**Routing
line**



**Connect-
ing meter-
ing pump**

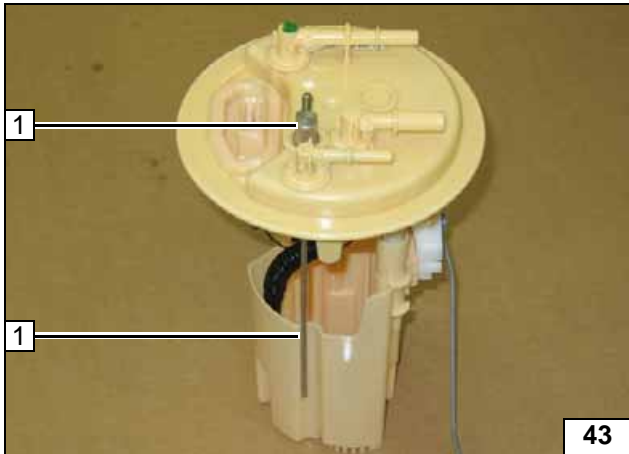

Shape fuel standpipe **1** as shown in the template and cut it to length.

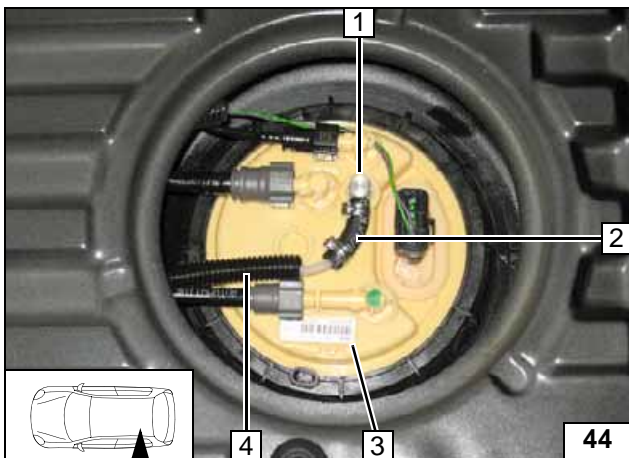

Install fuel-tank sending unit **3** in accordance with the manufacturer's instructions. Slide corrugated tube **4** onto fuel line.

- 1** Fuel standpipe
- 2** Hose section, 10mm dia.clamp [2x]

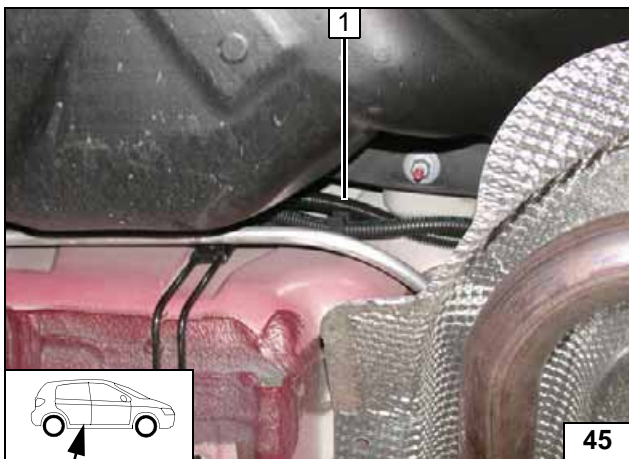

All vehicles

Route fuel line of fuel standpipe in corrugated tube **1** to installation location of metering pump.

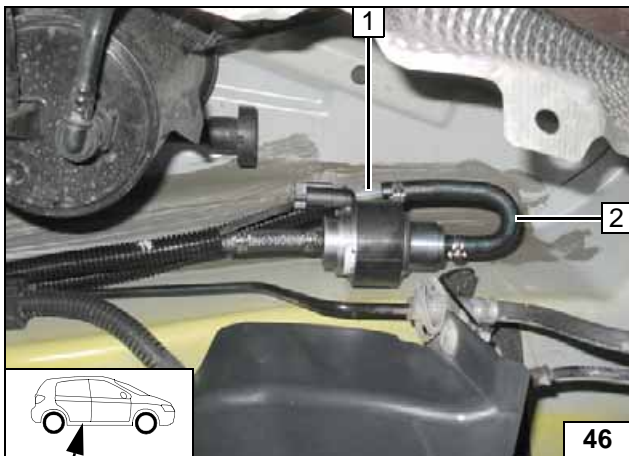

Check the position of the components; adjust if necessary. Check that they have freedom of movement.

- 1** Fuel line of fuel standpipe
- 2** 180° moulded hose, 10mm dia. clamp [2x]





VTi Coolant Circuit Diagram

WARNING!

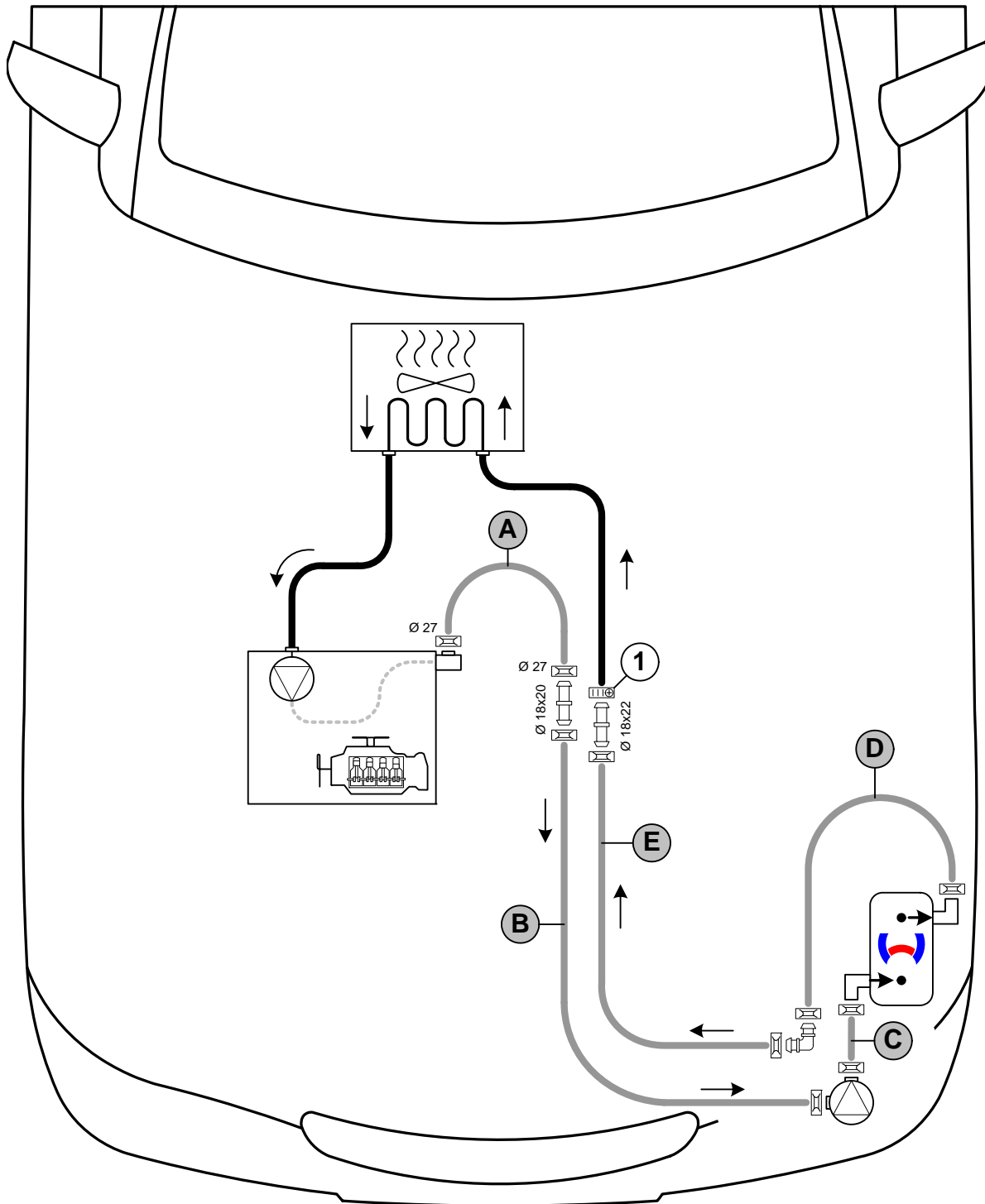
Any coolant running off should be collected in an appropriate container. Route hoses so that they are kink-free. Unless specified otherwise, always fasten using cable ties. Position clamps so that other hoses cannot be damaged. When installing the hoses, the heater must be filled with coolant. The connection should be "inline" based on the following diagram:



Hose routing diagram

All connecting pipes without a specific designation  = 25mm dia. **1** = Original vehicle clamp . Connecting pipes  = 18x18mm dia.





THP Coolant Circuit Diagram



WARNING!

Any coolant running off should be collected in an appropriate container. Route hoses so that they are kink-free. Unless specified otherwise, always fasten using cable ties. Position clamps so that other hoses cannot be damaged. When installing the hoses, the heater must be filled with coolant. The connection should be "inline" based on the following diagram:

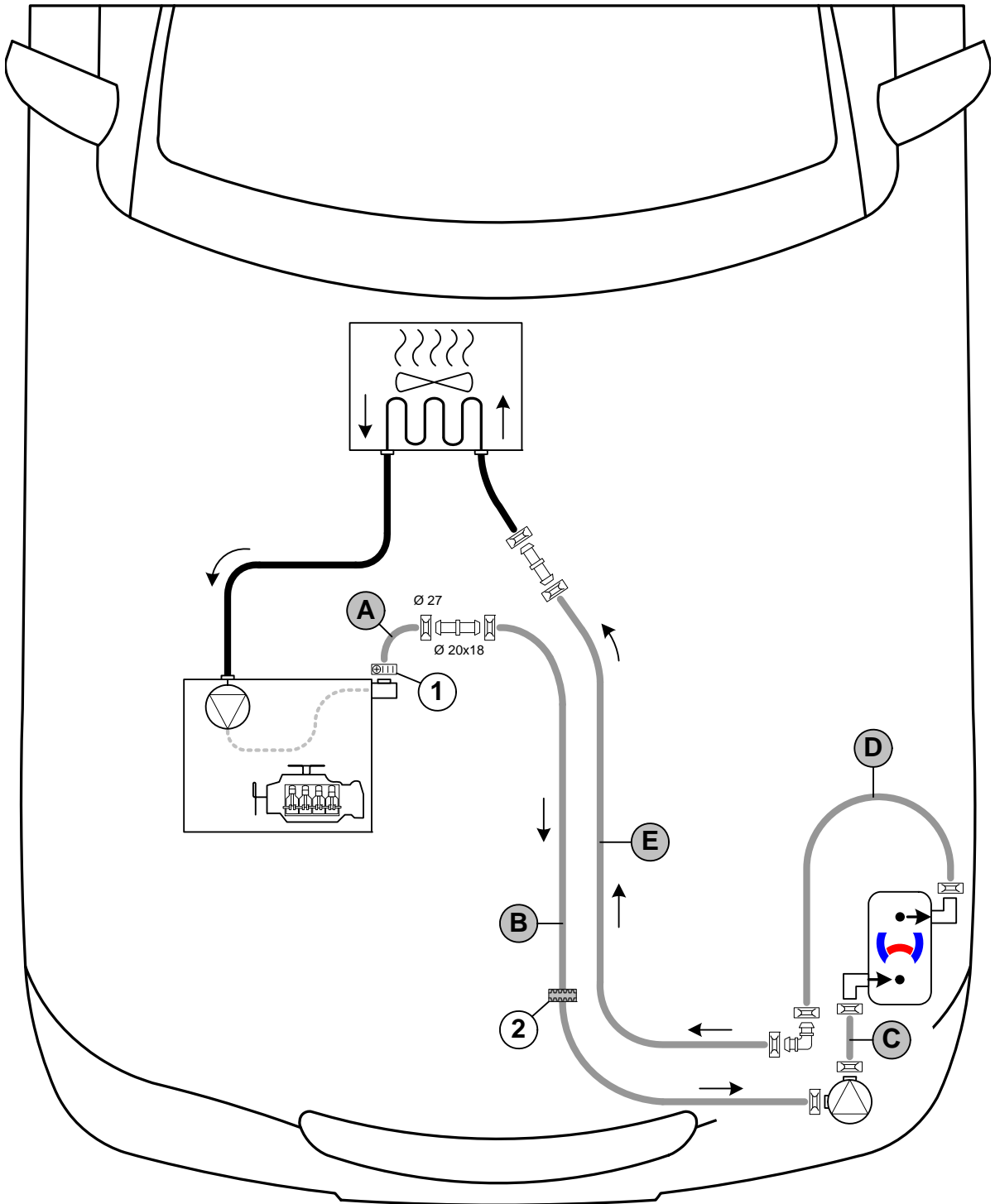

Hose routing diagram

All connecting pipes without a specific designation = 25mm dia. 1 = Original vehicle clamp . All connecting pipes without a specific designation and = 18x18mm dia. 2 = Black (sw) rubber isolator .







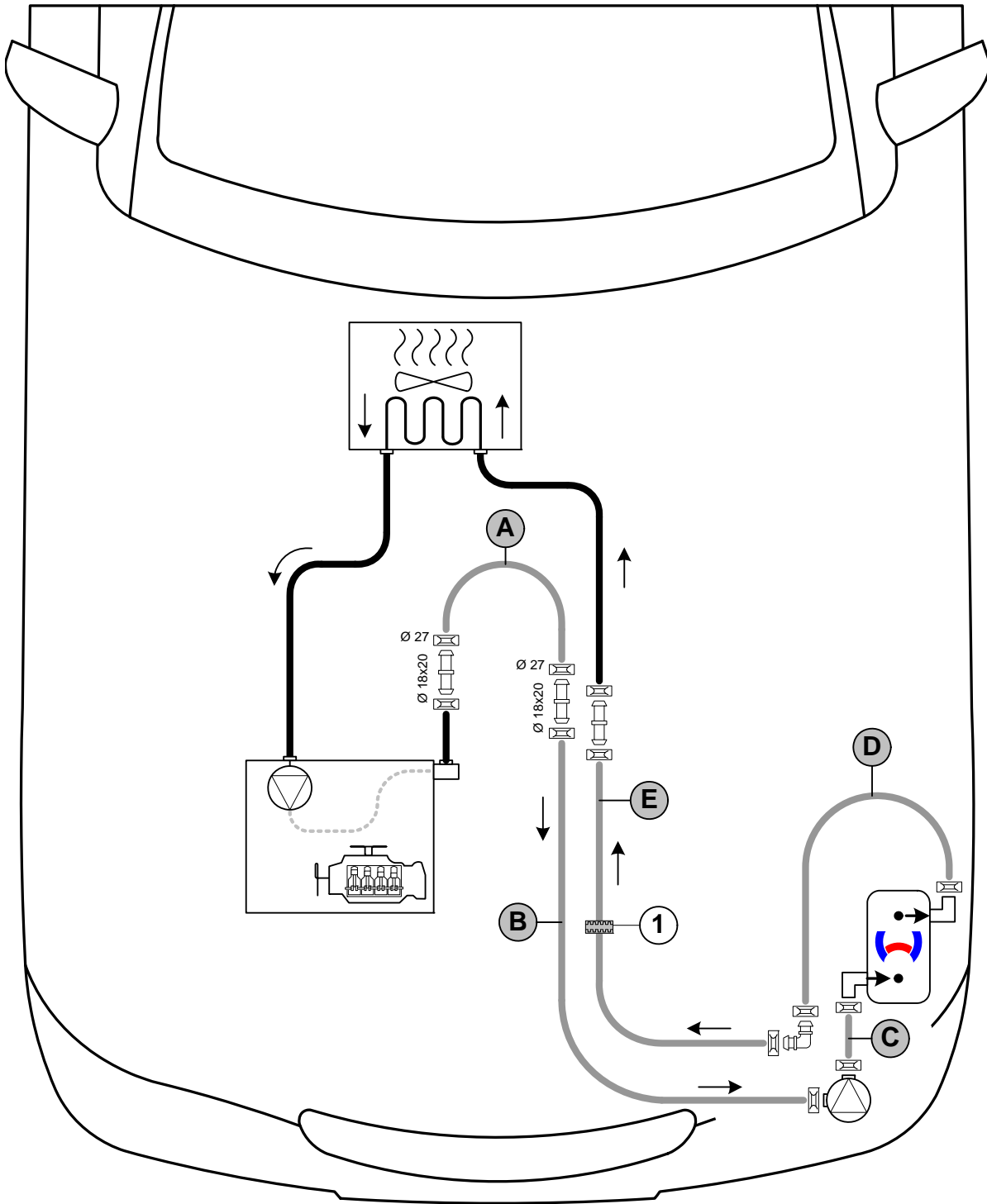

HDI Coolant Circuit Diagram

WARNING!

Any coolant running off should be collected in an appropriate container. Route hoses so that they are kink-free. Unless specified otherwise, always fasten using cable ties. Position clamps so that other hoses cannot be damaged. When installing the hoses, the heater must be filled with coolant. The connection should be "inline" based on the following diagram:



Hose routing diagram

All connecting pipes without a specific designation  = 25mm dia. 1 = Black (sw) rubber isolator  .
 All connecting pipes without a specific designation  and  = 18x18mm dia.



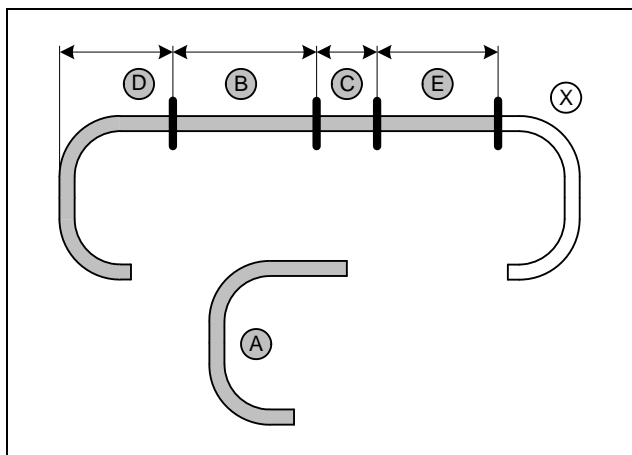

Preparing Coolant Circuit

VTi

Discard section X.
Hose A = 180°, 20x20mm moulded hose

- B** = 720
- C** = 160
- D** = 250
- E** = 750



Cutting hoses to length

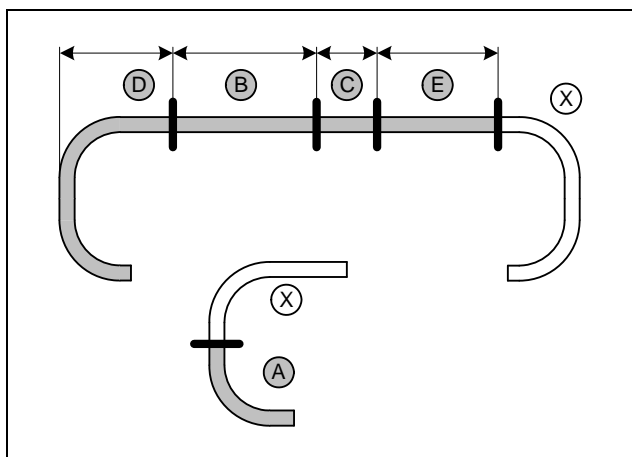

THP

Discard section X.
Hose A = 180°, 20x20mm moulded hose, shorten to 90°

- B** = 900
- C** = 160
- D** = 250
- E** = 800



Cutting hoses to length

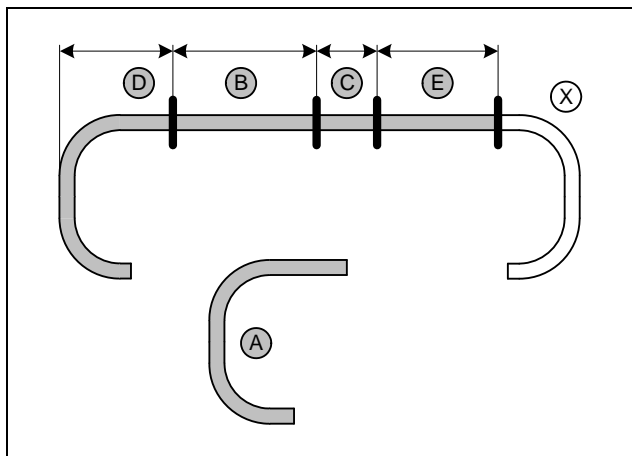

HDI

Discard section X.
Hose A = 180°, 20x20mm moulded hose

- B** = 850
- C** = 160
- D** = 250
- E** = 870



Cutting hoses to length

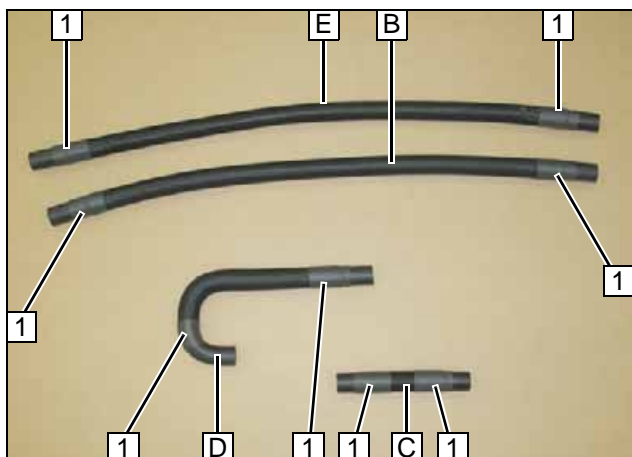

All vehicles

Push braided protection hoses onto hose B, C, D and E and cut to length.
Cut heat shrink plastic tubing to size.

- 1** 50 mm long heat shrink plastic tubing [8x]



Preparing hoses

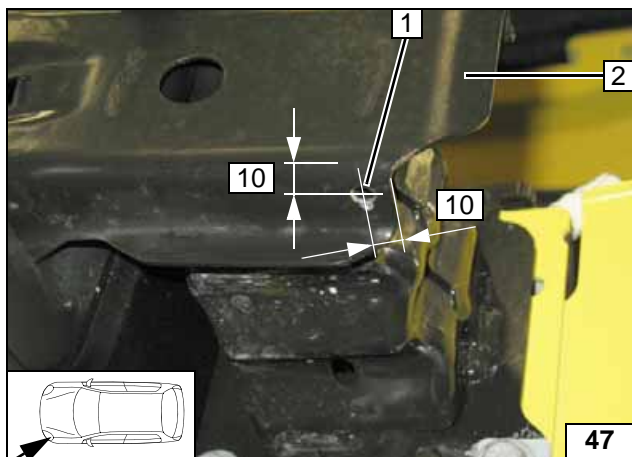

- 1 7 mm dia. hole
- 2 Bumper

Hole in bumper

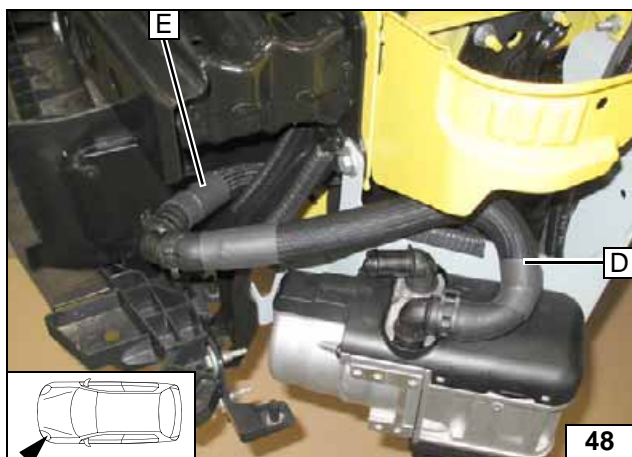

Route hose **E** in the engine compartment over the transmission.



Con-
nection of
heater out-
let

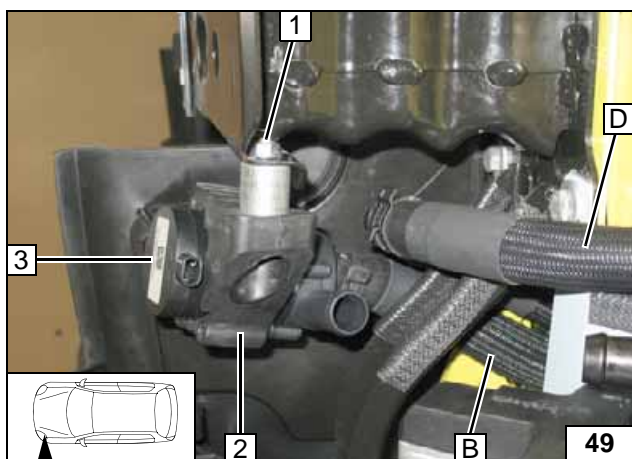

Route hose **B** to the engine compartment over the transmission.

- 1 M6x40 bolt, large diameter washer, 20mm shim, flanged nut, prepared hole
- 2 Bracket of circulating pump
- 3 Circulating pump



Installing
circulating
pump and
hose B

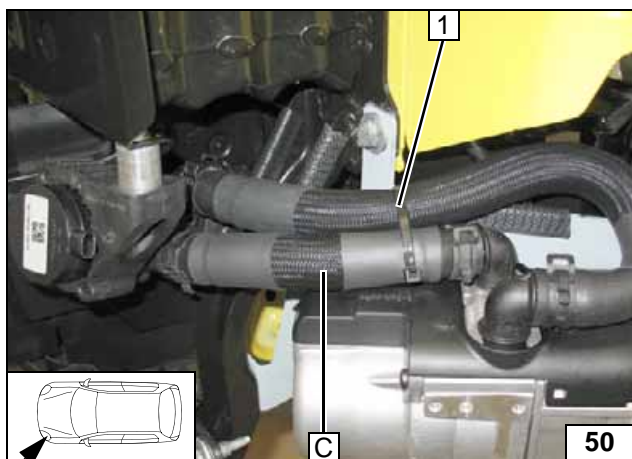

- 1 Cable tie

Con-
nection of
heater inlet

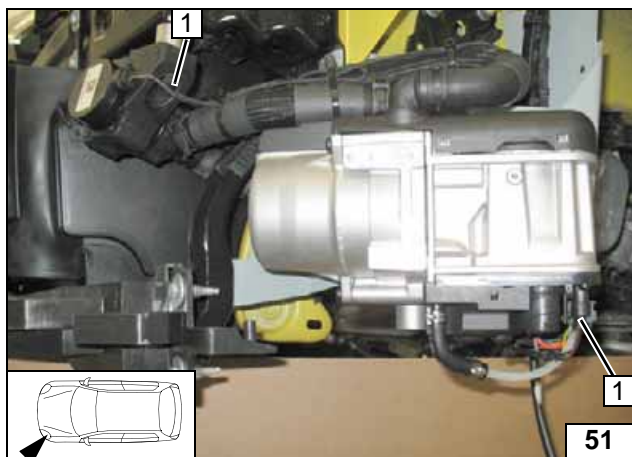

1 Wiring harness of circulating pump

Installing wiring harness of circulating pump

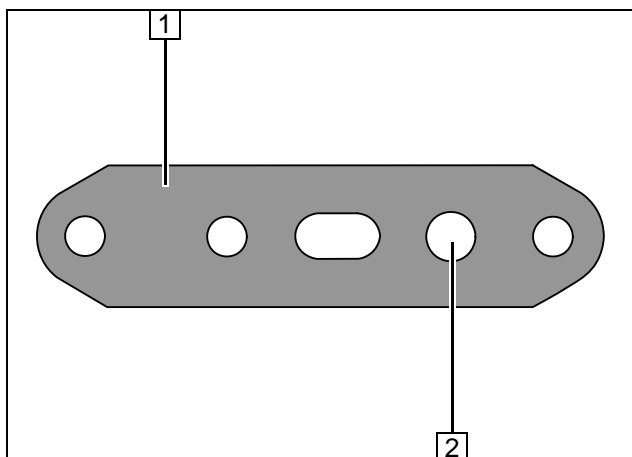

1 Perforated bracket
2 Drill out hole to 8 mm dia.

Preparing perforated bracket

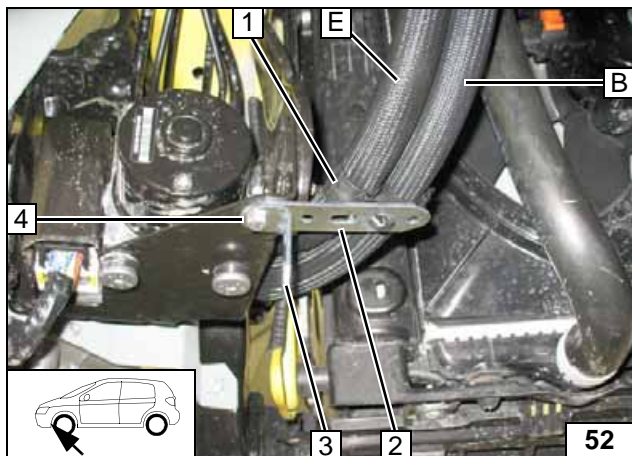

1 Spacer bracket
2 Perforated bracket
3 Angle bracket of exhaust silencer
4 M6x20 bolt, flanged nut, ABS bracket

Routing in engine compartment

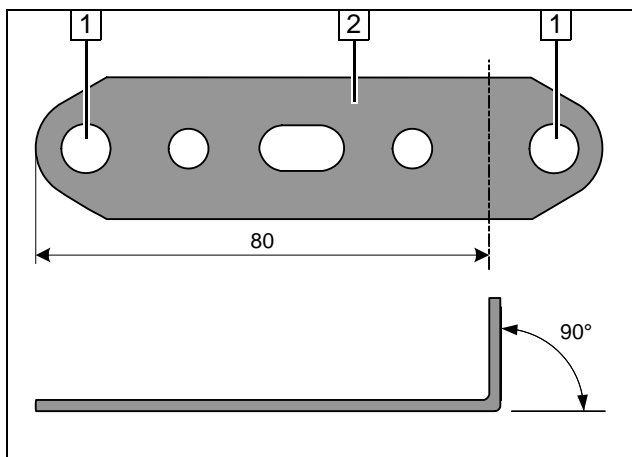

VTi Hose Routing

1 Drill out hole to 8 mm dia. [2x]
2 Angle down perforated bracket

Preparing perforated bracket

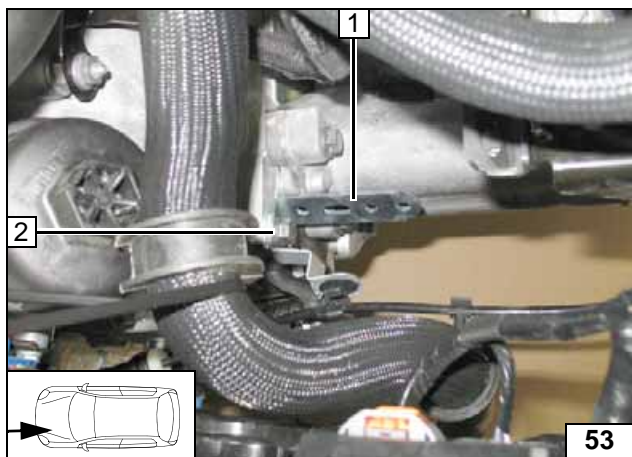
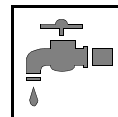

- 1 Perforated bracket
- 2 Original vehicle bolt, bracket of coupling line

Installing perforated bracket

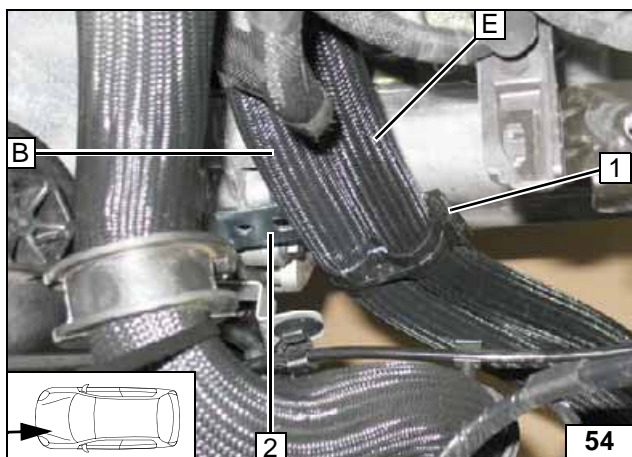

Insert spacer bracket 1 in 8mm hole of perforated bracket 2, align hoses and lock. Ensure adequate distance from transmission and radiator hose.



Routing in engine compartment



Pull out hose of engine outlet / heat exchanger inlet 1 from the connection piece of engine outlet. Original vehicle clamp will be reused.



Cutting point

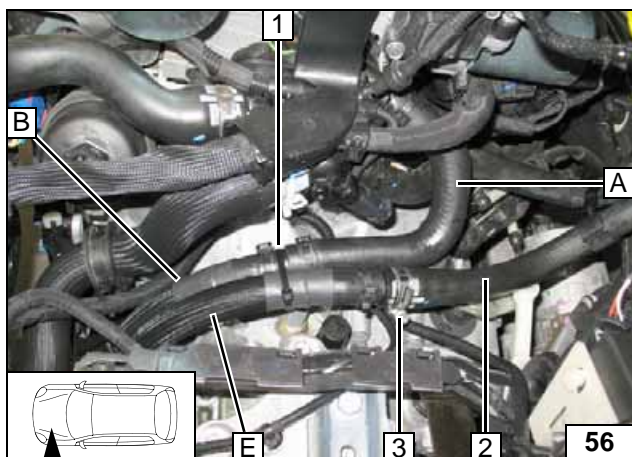

- 1 Cable tie
- 2 Hose of heat exchanger inlet
- 3 Original vehicle clamp

Connection of engine outlet and heat exchanger inlet

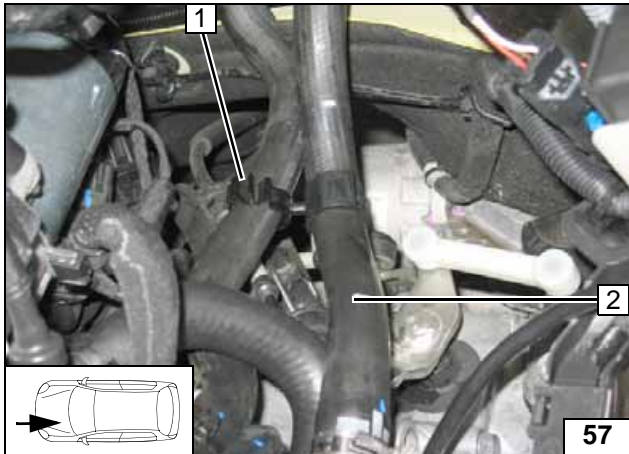

Align original vehicle spacer bracket 1. Ensure sufficient distance from adjacent components; especially from gear change.

2 Hose of heat exchanger inlet



Aligning hoses

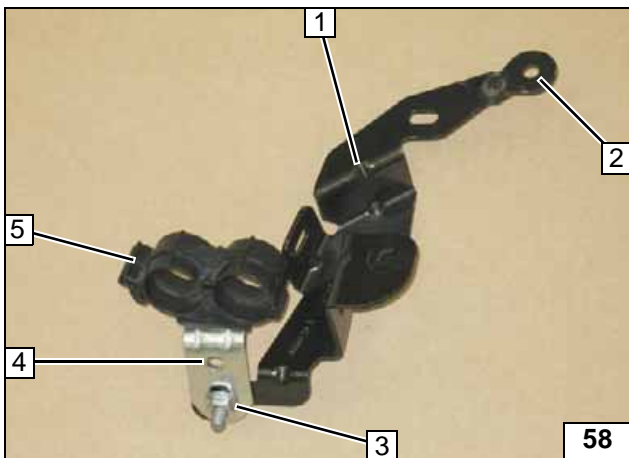

THP Hose Routing

Remove wiring harness bracket 1 on the transmission.

- 2 Straighten tab
- 3 M6x20 bolt, large diameter washer, flanged nut, existing hole
- 4 Angle bracket
- 5 Insert spacer bracket



Preparing wiring harness bracket of transmission

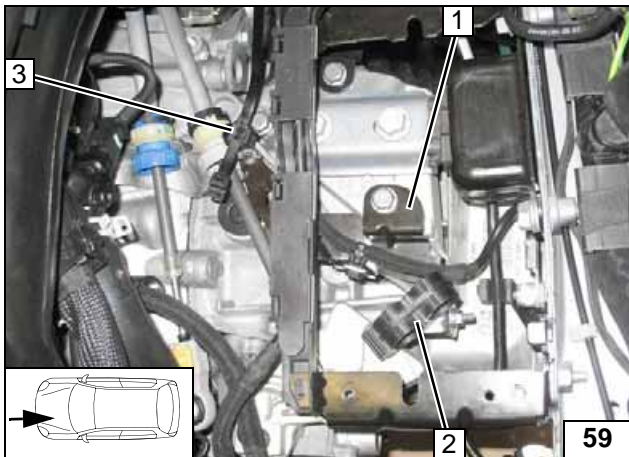

- 1 Wiring harness bracket
- 2 Align spacer bracket
- 3 Install clip-type cable tie (hole of mounting tab)

Mounting wiring harness bracket of transmission

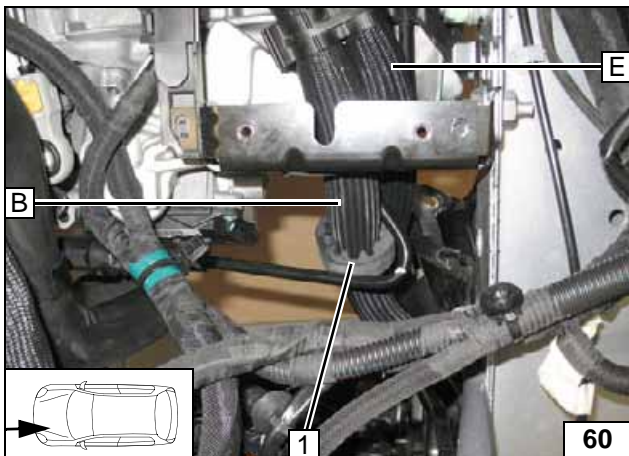

Push black (sw) rubber isolator 1 onto hose B.



Routing in engine compartment

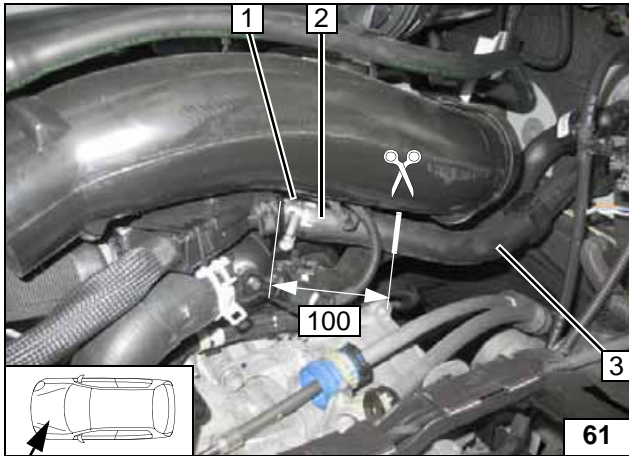

Remove hose section **2** and discard. Original vehicle clamp **1** will be reused.

3 Hose of heat exchanger inlet

Cutting point

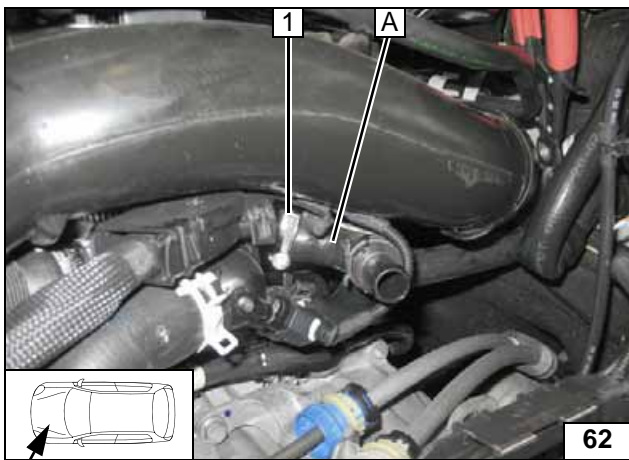

1 Original vehicle clamp

Connecting engine outlet

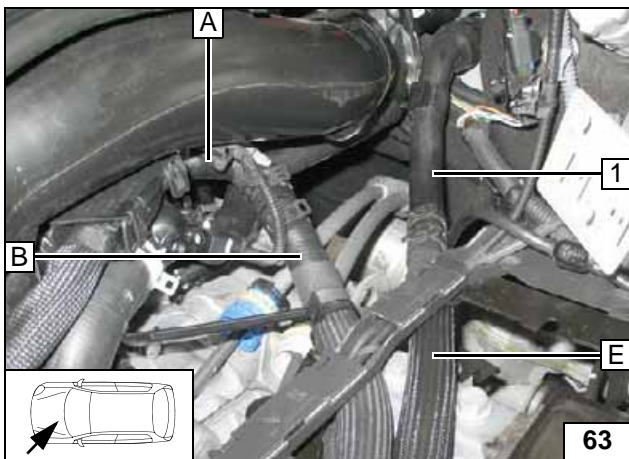

1 Hose of heat exchanger inlet

Connection of engine outlet and heat exchanger inlet



Route hose **B** and **E** through spacer bracket **1**, align hoses and shut lock. Close clip-type cable tie **2**. Ensure sufficient distance from adjacent components; especially from gear change.



Routing in engine compartment

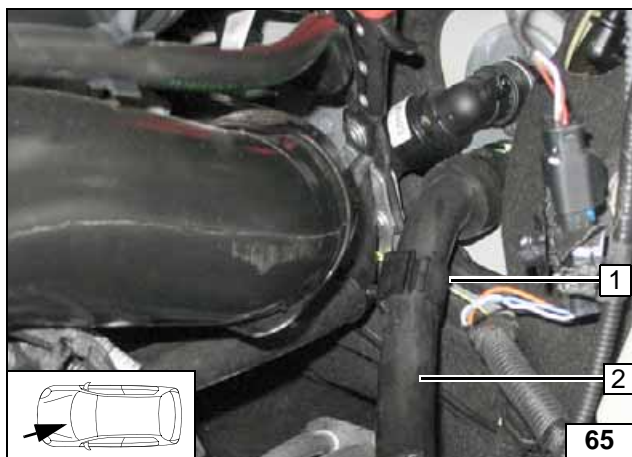

Align original vehicle spacer bracket 1.

2 Hose of heat exchanger inlet



Aligning hoses

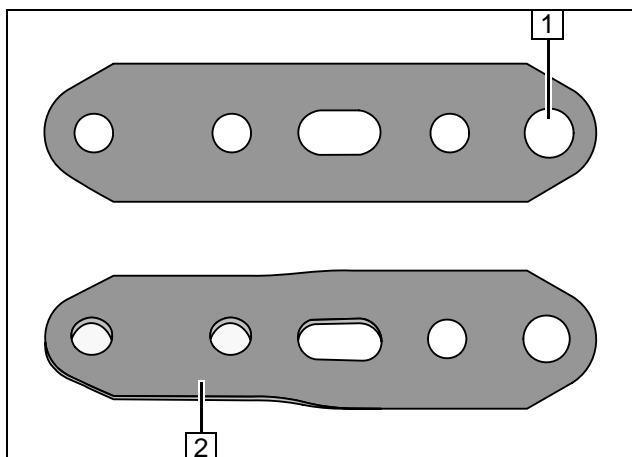

HDI Hose Routing

1 Drill out hole to 8 mm dia.

2 Turn perforated bracket by 15°

Preparing perforated bracket

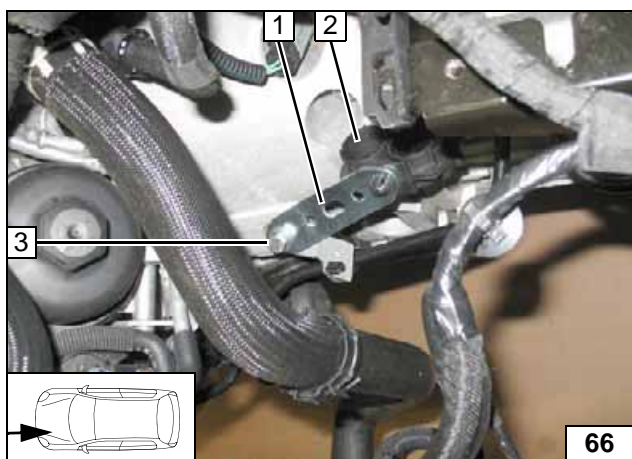

1 Perforated bracket

2 Hose bracket

3 Original vehicle bolt, bracket of coupling line

Installing perforated bracket

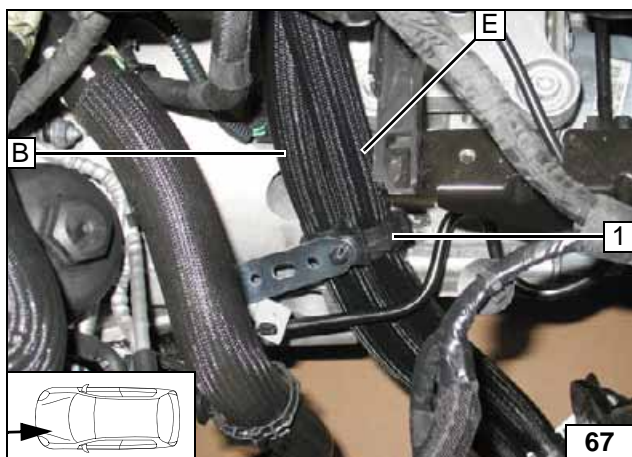

Route hose **B** and **E** through spacer bracket 1, align hoses and shut lock. Ensure sufficient distance from neighbouring components.



Routing in engine compartment

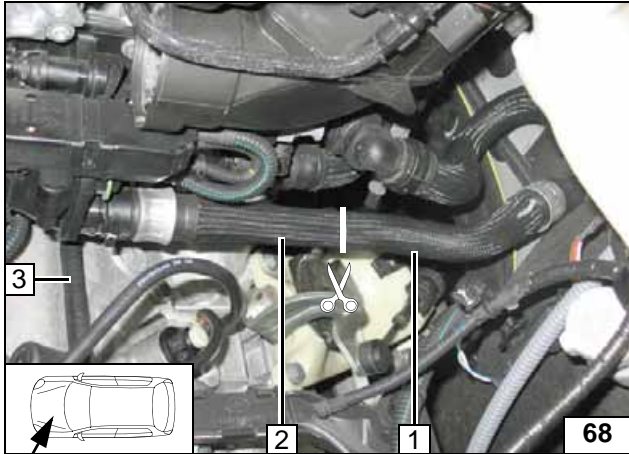

Mount 100mm edge protection onto edge of transmission at position **3**.

- 1 Hose section of heat exchanger inlet
- 2 Hose section of engine outlet



Cutting point

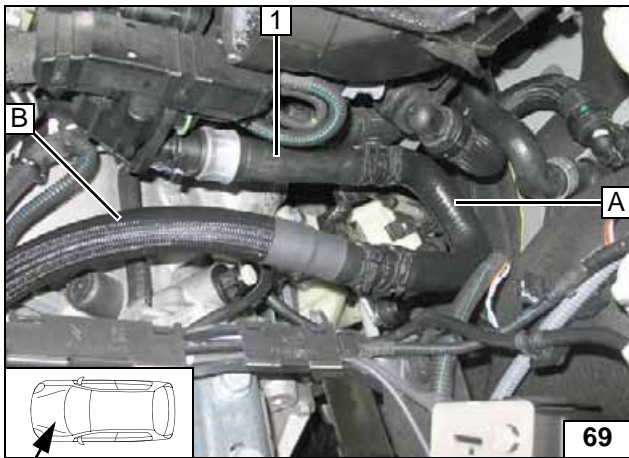

- 1 Hose of engine outlet

Connecting engine outlet

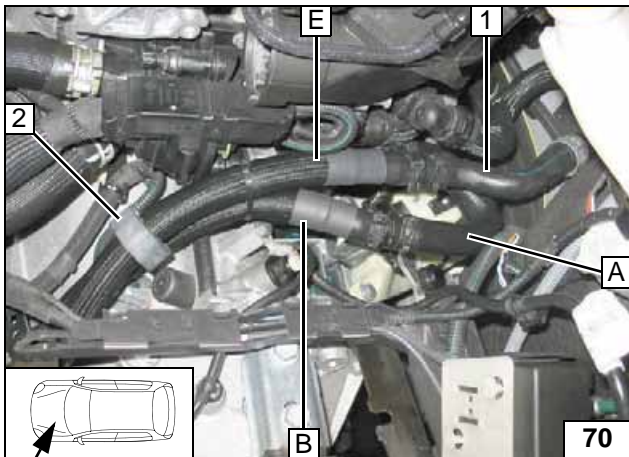

Push black (sw) rubber isolator **2** onto hose **E**.

- 1 Hose of heat exchanger inlet



Connecting heat exchanger inlet

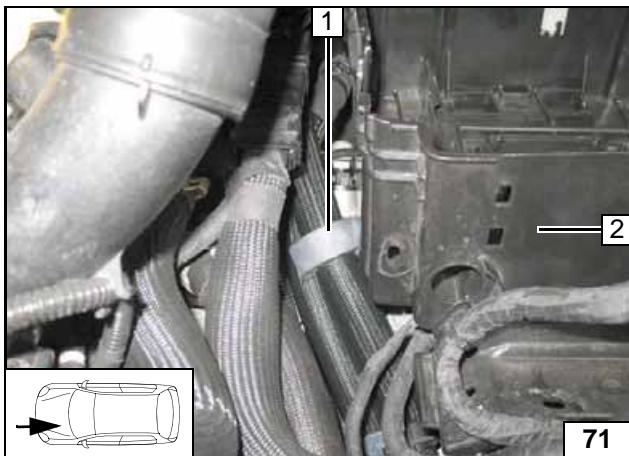

Align black (sw) rubber isolator **1** to battery box **2**.



Aligning rubber isolator

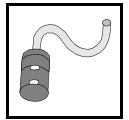

Cutting combustion air pipe to length



Mounting silencer

Combustion Air

Discard section X.

- 1 Combustion air pipe
a = 120

- 1 5x13 self-tapping bolt
- 2 Combustion air pipe
- 3 51 mm dia. p-clamp
- 4 Silencer

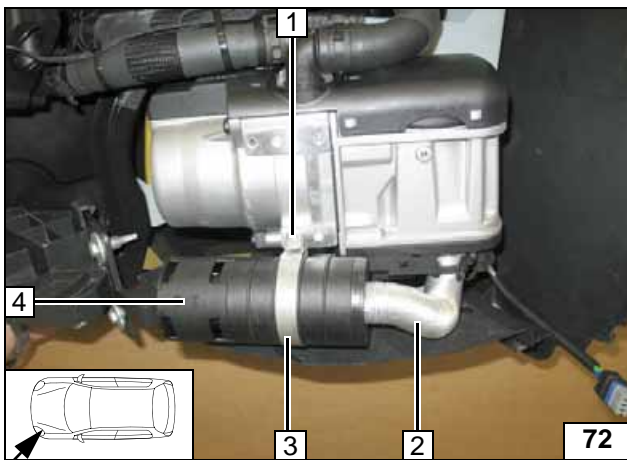
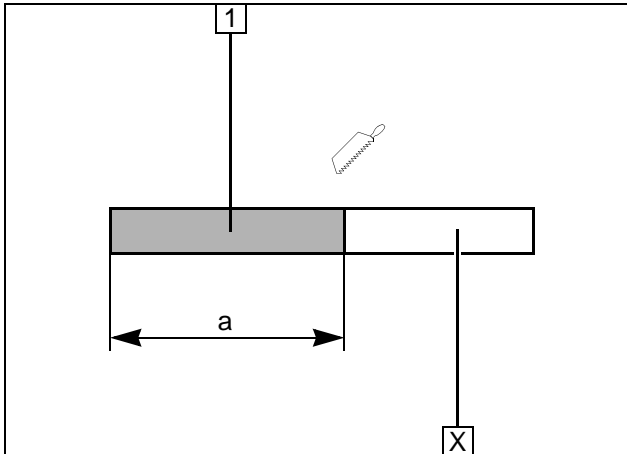

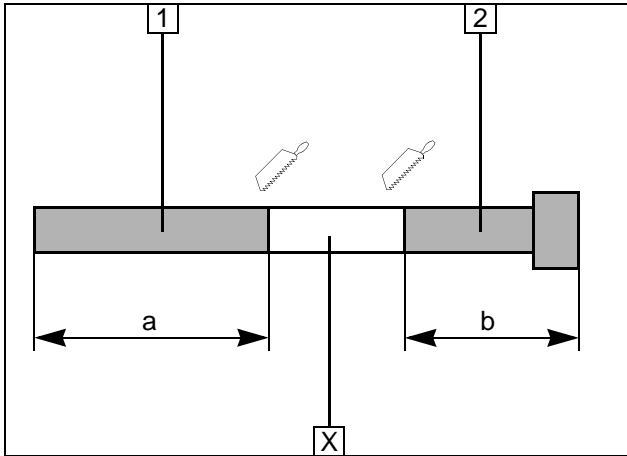
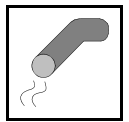

Exhaust Gas

Discard section X.

- 1 Exhaust pipe
a = 280
- 2 Exhaust end section
a = 310

Preparing exhaust pipe

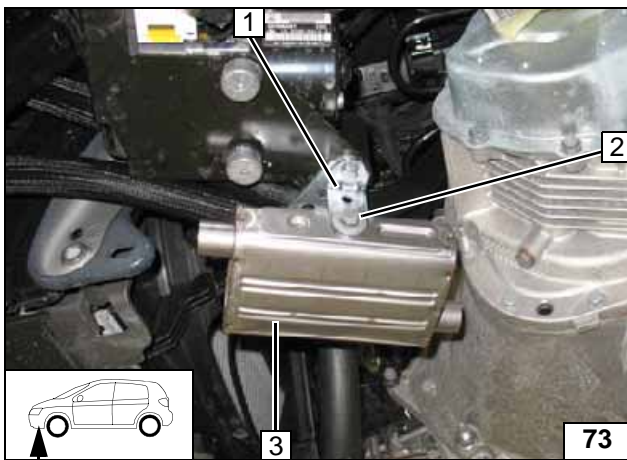

- 1 Premounted angle bracket
- 2 M6x16 bolt, spring lockwasher, large diameter washer
- 3 Exhaust silencer

Mounting silencer

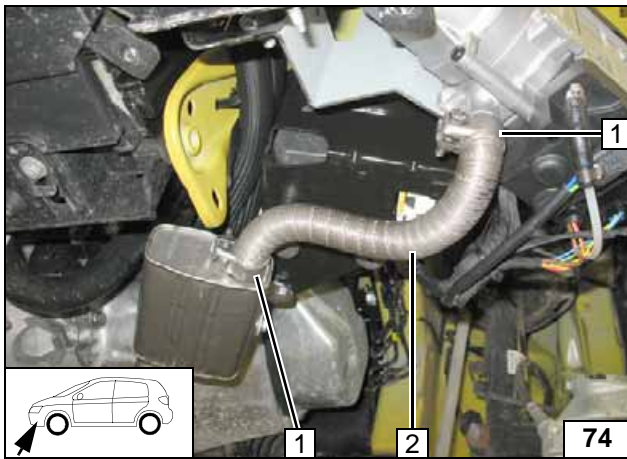

- 1 Hose clamp [2x]
- 2 Exhaust pipe

Installing exhaust pipe

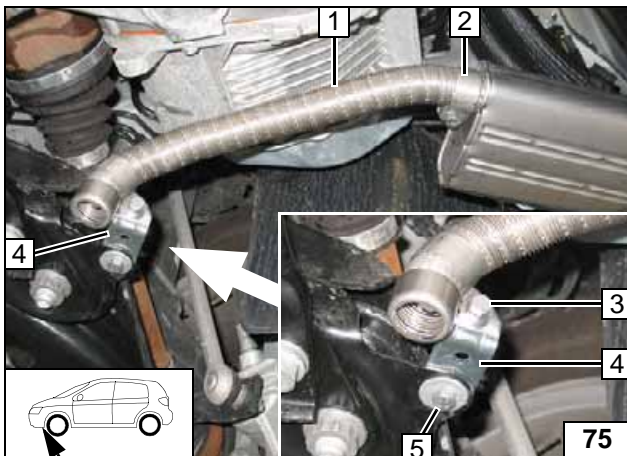

- 1 Align exhaust end section
- 2 Hose clamp
- 3 M6x20 bolt, p-clamp, flanged nut
- 4 Angle bracket
- 5 M6x20 bolt, large diameter washer [2x], flanged nut, existing hole

Installing exhaust end section

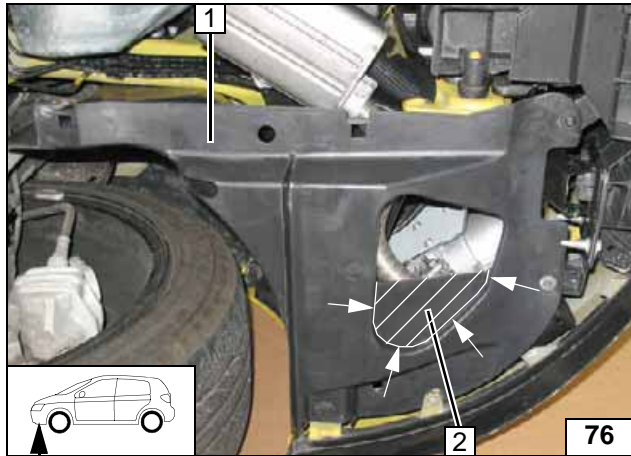
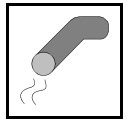

Cut out wheel well trim 1 at the marking. Discard section 2 .



Cutting out wheel well trim

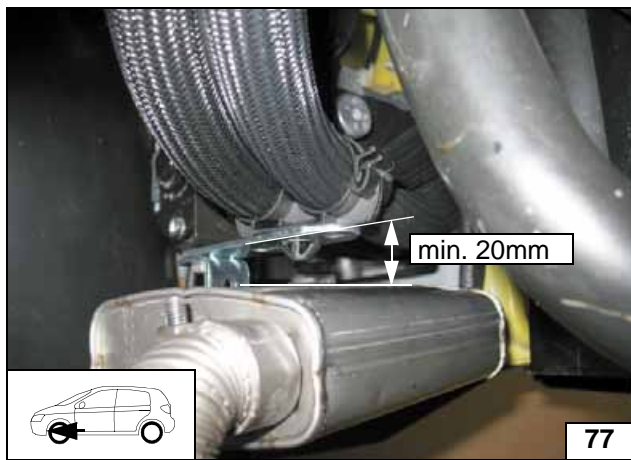

Ensure sufficient distance from perforated bracket; correct if necessary.



Aligning silencer

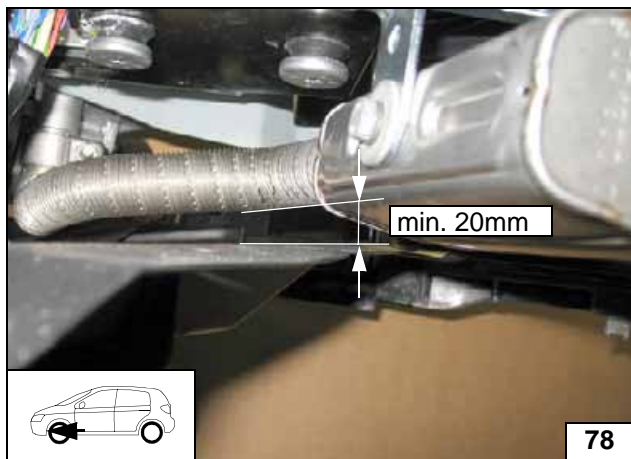

Ensure sufficient distance from wheel well trim; correct if necessary.



Aligning exhaust pipe

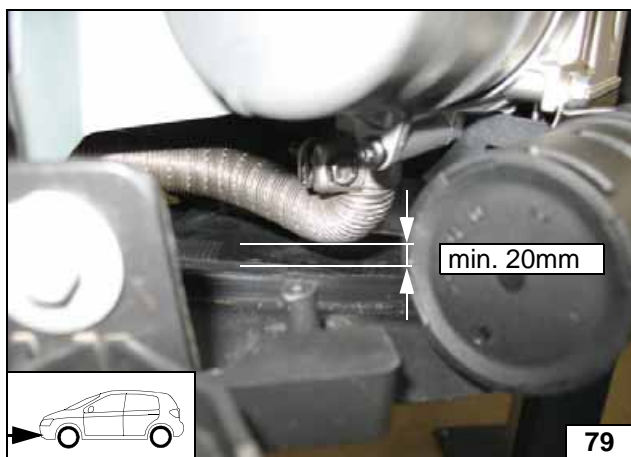

Ensure sufficient distance from wheel well trim; correct if necessary.



Aligning exhaust pipe

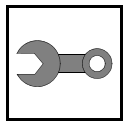

Final Work

WARNING!

Mount removed parts in reverse order. Check all hoses, clamps and all electrical connections for firm seating. Insulate all loose wires and tie back. Only use manufacturer-approved coolant. Spray the heater components with anti-corrosion wax (Tectyl 100K, Order No. 111329).



- **Connect the battery.**
- **Fill and bleed the coolant circuit according to the vehicle manufacturer's specifications.**
- **Adjust digital timer, teach telestart transmitter.**
- **Make settings on A/C control panel according to the "Operating Instructions for End Customer".**
- **Place the "Switch off parking heater before refuelling" caution label in the area of the filler neck.**
- **For initial startup and function check, please see installation instructions.**

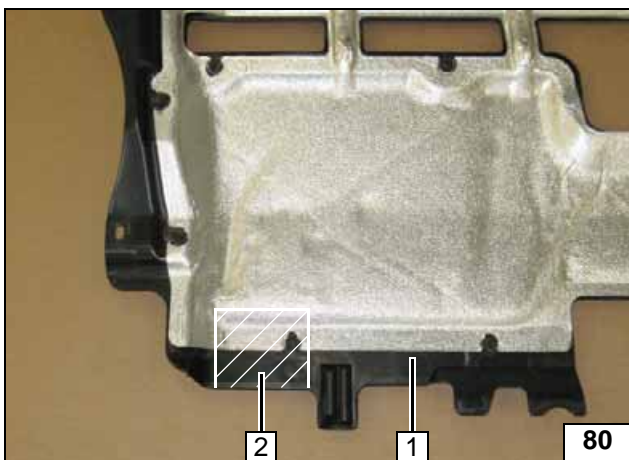

Vehicles with underride protection

Cut out underride protection 1 at the marking. Discard section 2 .

Cutting out underride protection

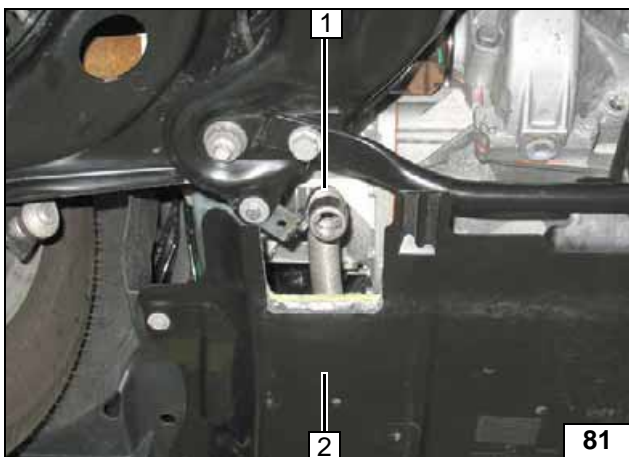

Ensure sufficient distance between exhaust end section 1 and underride protection 2, correct if necessary!



Mounting underride protection

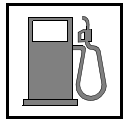

Template for Petrol Fuel Standpipe

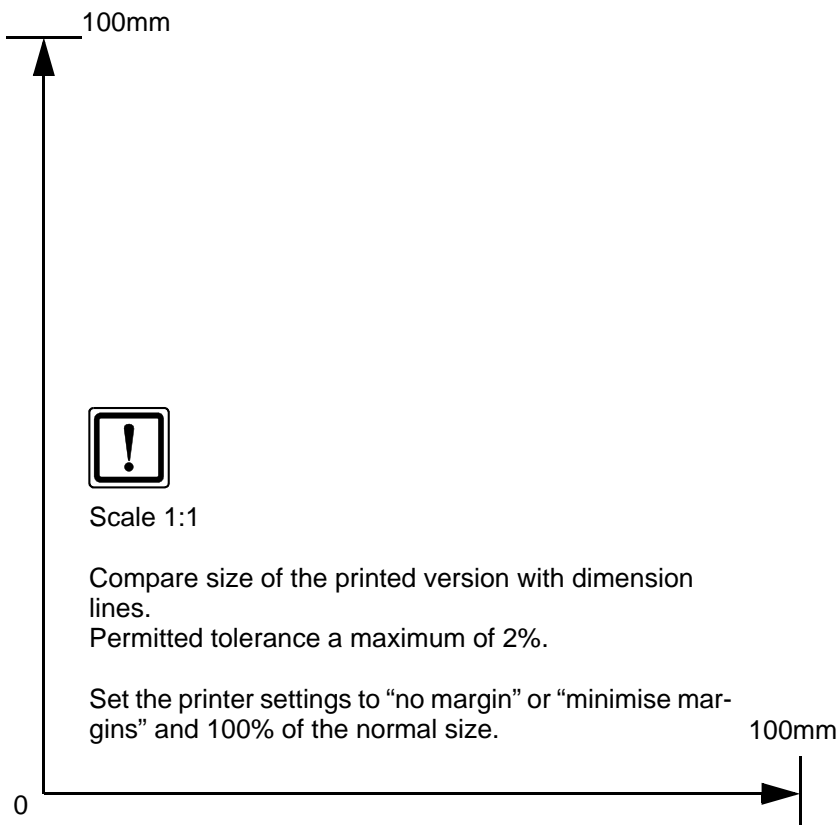
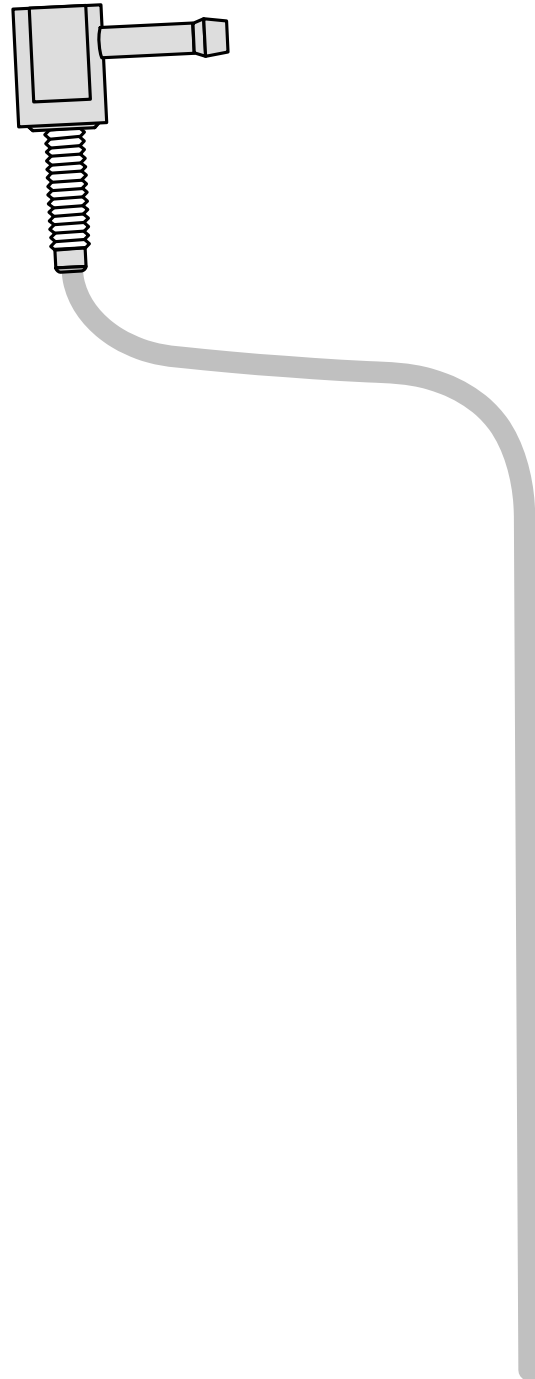

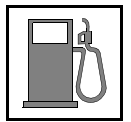

Template for Diesel Fuel Standpipe

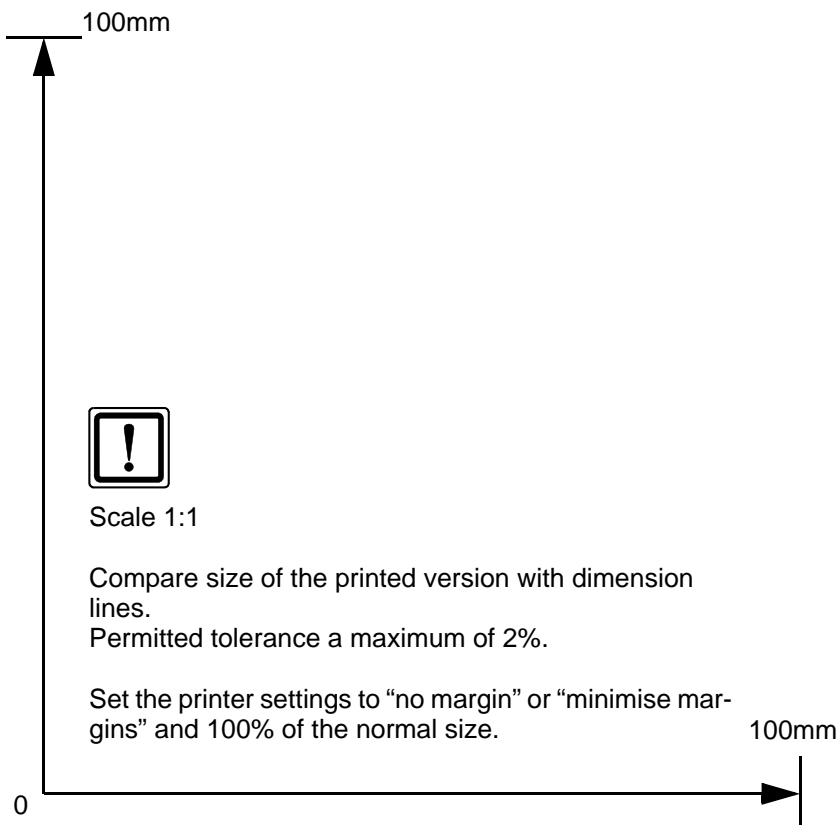

Operating Instructions for Manual Air-Conditioning

Please remove page and add to the vehicle operating instructions.

Note:

We recommend matching the heating time to the driving time.

Heating time = driving time

Example:

For a driving time of approx. 20 min. (in one direction), we recommend not exceeding a switch-on time of 20 min.

Passenger compartment monitoring, if installed, must be deactivated in addition to the vehicle settings for the heating operation.

For instructions on deactivation, please refer to the operating instructions of the vehicle.

Before parking the vehicle, make the following settings:

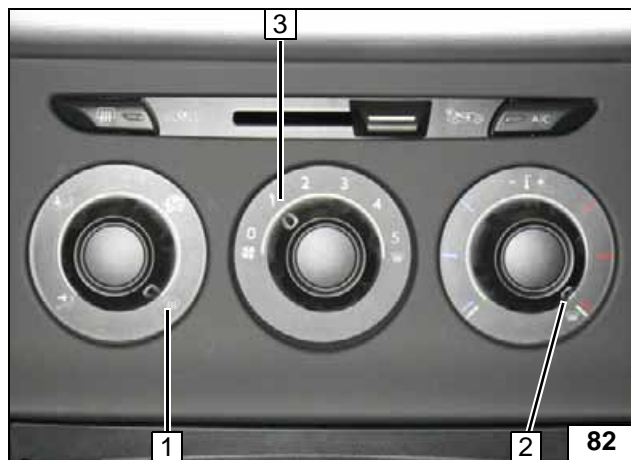

- 1 Air outlet onto windscreen
- 2 Set temperature to "max."
- 3 Set fan to level "1", or possibly "2"



A/C control panel

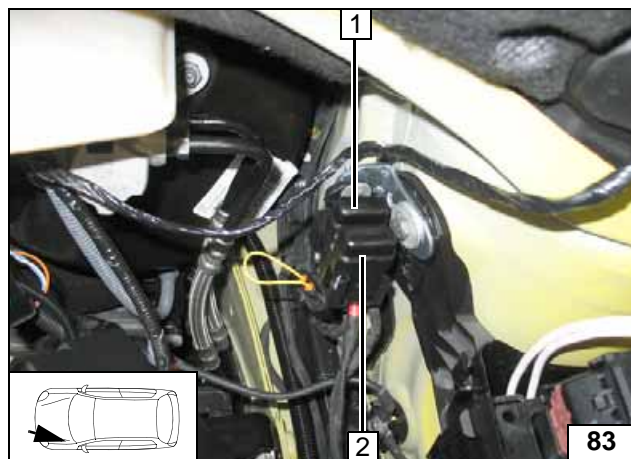

- 1 30A passenger compartment main fuse F2
- 2 20A heater fuse F1

Fuses of engine compartment

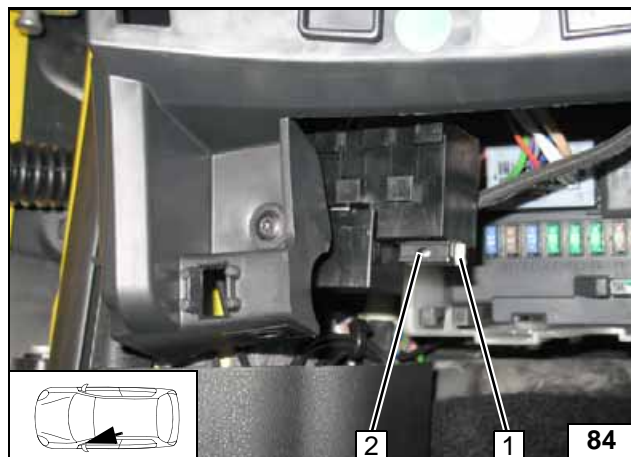

- 1 1A fuse of heater control F3
- 2 25A fan fuse F4

Fuses of passenger compartment



Operating Instructions Automatic Air-Conditioning

Please remove page and add to the vehicle operating instructions.

Note:

We recommend matching the heating time to the driving time.
 Heating time = driving time

Example:

For a driving time of approx. 20 min. (in one direction), we recommend not exceeding a switch-on time of 20 min.

Passenger compartment monitoring, if installed, must be deactivated in addition to the vehicle settings for the heating operation.

For instructions on deactivation, please refer to the operating instructions of the vehicle.

Before parking the vehicle, make the following settings:

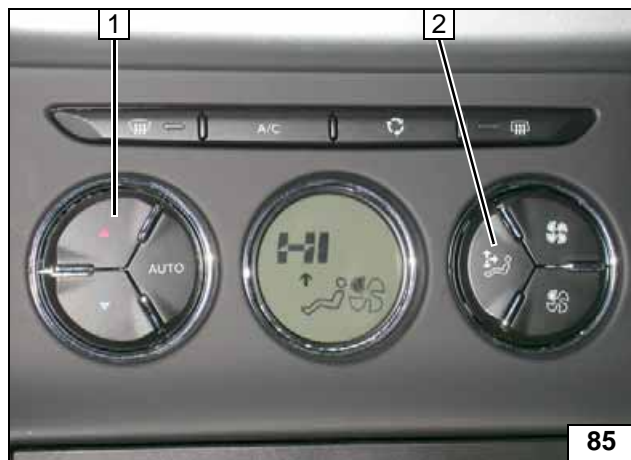

- 1 Set temperature to "HI"
- 2 Air outlet faces upward



A/C control panel

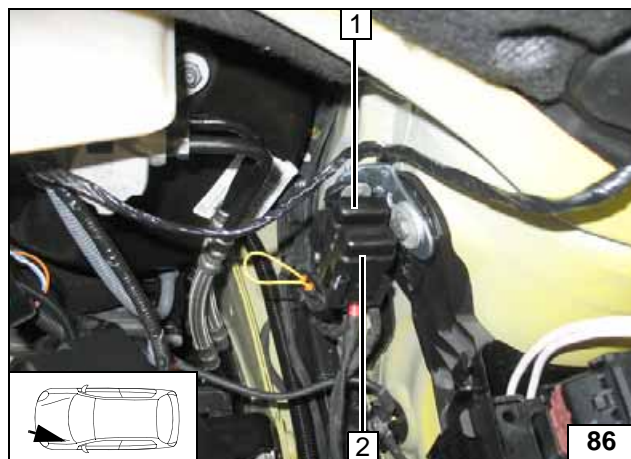

- 1 30A passenger compartment main fuse F2
- 2 20A heater fuse F1

Fuses of engine compartment

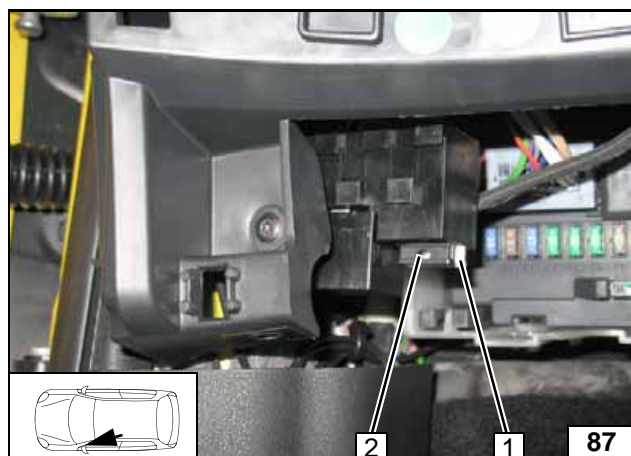

- 1 1A fuse of heater control F3
- 2 25A fan fuse F4

Fuses of passenger compartment

